

# INSTALLATION MANUAL

## R-410A ZY SERIES

3 - 10 Ton

60 Hertz



### TABLE OF CONTENTS

General	2	Economizer Sequences	88
Installation	5	Dry Bulb Changeover	88
Preceding Installation	5	Single Enthalpy Changeover	88
Limitations	6	Dual Enthalpy Changeover	88
Location	6	Auto	88
Rigging And Handling	7	Free Cooling Operation	89
ZY04-12 Unit Weights	8	Power Exhaust	89
Ductwork	16	Setpoints	89
Condensate Drain	17	Inputs	89
Compressors	18	Outputs	89
Filters	18	Operation	89
Power And Control Wiring	18	Gas Heating Operation	93
Typical Field Power and Control Wiring	20	Gas Heat Ignition Control Board Function	94
Typical Power Wiring	20	Start-Up (Cooling)	95
Options/Accessories	67	Start-Up (Gas Heat)	96
Blower Phasing	67	Checking Gas Heat Input	96
Airflow Performance	70	Troubleshooting	101
Operation	88	Smart Equipment™ Control Board Navigation Components	110
Compressor Operation	88	Start-Up Sheet	111
IntelliSpeed™ Supply Fan Control	88		

### LIST OF TABLES

1	ZY04-12 Unit Limitations	6	21	Motor Sheave Datum Diameters	80
2	ZY04-12 Corner Weights	8	22	Additional Static Resistance - ZY04-12	81
3	ZY04-12 Unit Accessory Weights	9	23	Smart Equipment™ UCB Details	82
4	ZY04-06 Unit Clearances	15	24	Cable for FC Buses and SA Buses in Order of Preference	87
5	ZYA7 and ZY07-12 Unit Clearances	15	25	Smart Equipment™ Economizer Board Details	90
6	Unit Models used with 1RC0456, 1RC0458 Roof Curb	15	26	Gas Rate Cubic Feet Per Hour	97
7	Unit Models used with 1RC0457, 1RC0459 Roof Curb	16	27	Gas Heat Stages	98
8	Control Wire Sizes	19	28	Flash Codes for the Gas Heat Ignition Control Board	101
9	Electrical Data	21	29	ZY04 Charging Table	104
10	Physical Data	49	30	ZY05 Charging Table	104
11	Gas Pipe Sizing - Capacity of Pipe	65	31	ZY06 Charging Table	105
12	Gas Heat Supply Air	65	32	ZY07 Charging Table	105
13	Supply Air Limitations	67	33	ZYA7 Charging Table	106
14	Altitude/Temperature Correction Factors	69	34	ZY08 Charging Table System 1	106
15	ZY04-12 Side Duct Application (Belt Drive)	71	35	ZY08 Charging Table System 2	107
16	ZY04-06 Side Duct Application (Direct Drive)	74	36	ZY09 Charging Table System 1	107
17	ZY04-12 Bottom Duct Application (Belt Drive)	75	37	ZY09 Charging Table System 2	108
18	ZY04-06 Bottom Duct Application (Direct Drive)	78	38	ZY12 Charging Table System 1	108
19	RPM Selection	79	39	ZY12 Charging Table System 2	109
20	Indoor Blower Specifications	79			

### LIST OF FIGURES


1	Unit Shipping Bracket	5	16	Bottom Supply Opening For Side Duct Conversion	17
2	Condenser Covering	5	17	Condensate Drain	18
3	Return Air Smoke Detector Field Location	5	18	Typical Smart Equipment™ Control Wiring	20
4	Unit 4 Point Load Weight	8	19	Side Entry Gas Piping	65
5	Unit 6 Point Load Weight	8	20	Flue Exhaust Hood Shipping Location	66
6	Center of Gravity	8	21	Flue Exhaust Hood Installed	67
7	ZY04 Unit Dimensions	10	22	Belt Adjustment	68
8	ZY05-06 Unit Dimensions	11	23	Altitude/Temperature Correction Factors	69
9	ZY07 and ZYA7 Unit Dimensions	12	24	Unit Control Board	82
10	ZY08/09 Unit Dimensions	13	25	SE-ECO1001-1 Economizer Controller	90
11	ZY12 Unit Dimensions	14	26	Ignition Control Board	93
12	1RC0456, 1RC0458 Roof Curb Dimensions	15	27	Typical Flame	99
13	1RC0457, 1RC0459 Roof Curb Dimensions	16	28	3 Thru 5 Ton, 1/2" Single Stage Gas Valve	99
14	Side Duct Cover Panels	17	29	3 Thru 5 Ton, 1/2" Two Stage Gas Valve	100
15	Bottom Return Opening For Side Duct Conversion	17	30	6 Thru 12.5 Ton 3/4" Two Stage Gas Valve	100

## General

ZY units are single package air conditioners with optional gas heating designed for outdoor installation on a rooftop or slab and for non-residential use.

These units are completely assembled on rigid, permanently attached base rails. All piping, refrigerant charge, and electrical wiring is factory installed and tested. The units require electric power, gas supply (where applicable), and duct connections.

### Safety Considerations

 This is a safety alert symbol. When you see this symbol on labels or in manuals, be alert to the potential for personal injury.

Understand and pay particular attention the signal words **DANGER**, **WARNING** or **CAUTION**.

**DANGER** indicates an **imminently** hazardous situation, which, if not avoided, **will result in death or serious injury**.

**WARNING** indicates a **potentially** hazardous situation, which, if not avoided, **could result in death or serious injury**.

**CAUTION** indicates a potentially hazardous situation, which, if not avoided **may result in minor or moderate injury**. It is also used to alert against unsafe practices and hazards involving only property damage.

### WARNING

Improper installation may create a condition where the operation of the product could cause personal injury or property damage. Improper installation, adjustment, alteration, service or maintenance can cause injury or property damage. Refer to this manual for assistance or for additional information, consult a qualified contractor, installer or service agency.

### CAUTION

This product must be installed in strict compliance with the installation instructions and any applicable local, state and national codes including, but not limited to building, electrical, and mechanical codes.

### WARNING

Before performing service or maintenance operations on unit, turn off main power switch to unit. Electrical shock could cause personal injury. Improper installation, adjustment, alteration, service or maintenance can cause injury or property damage. Refer to this manual. For assistance or additional information consult a qualified installer, service agency or the gas supplier.

### CAUTION

This system uses R-410A Refrigerant which operates at higher pressures than R-22. No other refrigerant may be used in this system. Gauge sets, hoses, refrigerant containers and recovery systems must be designed to handle R-410A. If you are unsure, consult the equipment manufacturer. Failure to use R-410A compatible servicing equipment may result in property damage or injury.

### WARNING

If the information in this manual is not followed exactly, a fire or explosion may result causing property damage, personal injury or loss of life.

Do not store or use gasoline or other flammable vapors and liquids in the vicinity of this or any other appliance.

WHAT TO DO IF YOU SMELL GAS:

- a. Do not try to light any appliance.
- b. Do not touch any electrical switch; do not use any phone in your building.
- c. Immediately call your gas supplier from a neighbor's phone. Follow the gas supplier's instructions.
- d. If you cannot reach your gas supplier, call the fire department.

Installation and service must be performed by a qualified installer, service agency or the gas supplier.

### WARNING

**ELECTRICAL SHOCK, FIRE OR EXPLOSION HAZARD**

Failure to follow safety warnings exactly could result in dangerous operation, serious injury, death or property damage.

Improper servicing could result in dangerous operation, serious injury, death or property damage.

- Before servicing, disconnect all electrical power to furnace.
- When servicing controls, label all wires prior to disconnecting. Reconnect wires correctly.
- Verify proper operation after servicing.

Due to system pressure, moving parts, and electrical components, installation and servicing of air conditioning equipment can be hazardous. Only qualified, trained service personnel should install, repair, or service this equipment. Untrained personnel can perform basic maintenance functions of cleaning coils and filters and replacing filters.

Observe all precautions in the literature, labels, and tags accompanying the equipment whenever working on air

conditioning equipment. The installation must conform with local building codes or, in the absence of local codes, with the National Fuel Gas Code, ANSI Z223.1/NFPA 54, and/or the National Gas and Propane Installation Code, CSA B149.1.

Wear safety glasses and work gloves. Use quenching cloth and have a fire extinguisher available during brazing operations.

### Inspection

As soon as a unit is received, it should be inspected for possible damage during transit. If damage is evident, the extent of the damage should be noted on the carrier's freight bill. A separate request for inspection by the carrier's agent should be made in writing.

### CAUTION

This product must be installed in strict compliance with the enclosed installation instructions and any applicable local, state and national codes including, but not limited to, building, electrical, and mechanical codes.

The furnace and its individual shut-off valve must be disconnected from the gas supply piping system during any pressure testing at pressures in excess of 1/2 PSIG.

Pressures greater than 1/2 PSIG will cause gas valve damage resulting in a hazardous condition. If it is subjected to a pressure greater than 1/2 PSIG, the gas valve must be replaced.

The furnace must be isolated from the gas supply piping system by closing its individual manual shut-off valve during any pressure testing of the gas supply piping system at test pressures equal to or less than 1/2 PSIG

### Reference

Additional information is available in the following reference forms:

- Technical Guide - ZX/ZY/ZQ04-14 1068152
- General Installation - ZY04-12 5513332
- Economizer Accessory -  
Vertical Flow Dry Bulb Economizer Field Installed  
Horizontal Flow Dry Bulb Economizer Field Installed

- Power Exhaust -  
Vertical Flow Dry Bulb Economizer Field Installed  
Horizontal Flow Dry Bulb Economizer Field Installed

### Renewal Parts

Contact your local UP parts distribution center for authorized replacement parts.

### Approvals

Design certified by CSA as follows:

1. For use as a cooling only unit, cooling unit with a forced air furnace.
2. For outdoor installation only.
3. For installation on combustible material and may be installed directly on combustible flooring or, in the U.S., on wood flooring or Class A, Class B or Class C roof covering materials.
4. For use with natural gas.

### CAUTION

This product must be installed in strict compliance with the enclosed installation instructions and any applicable local, state, and national codes including, but not limited to, building, electrical, and mechanical codes.

### WARNING

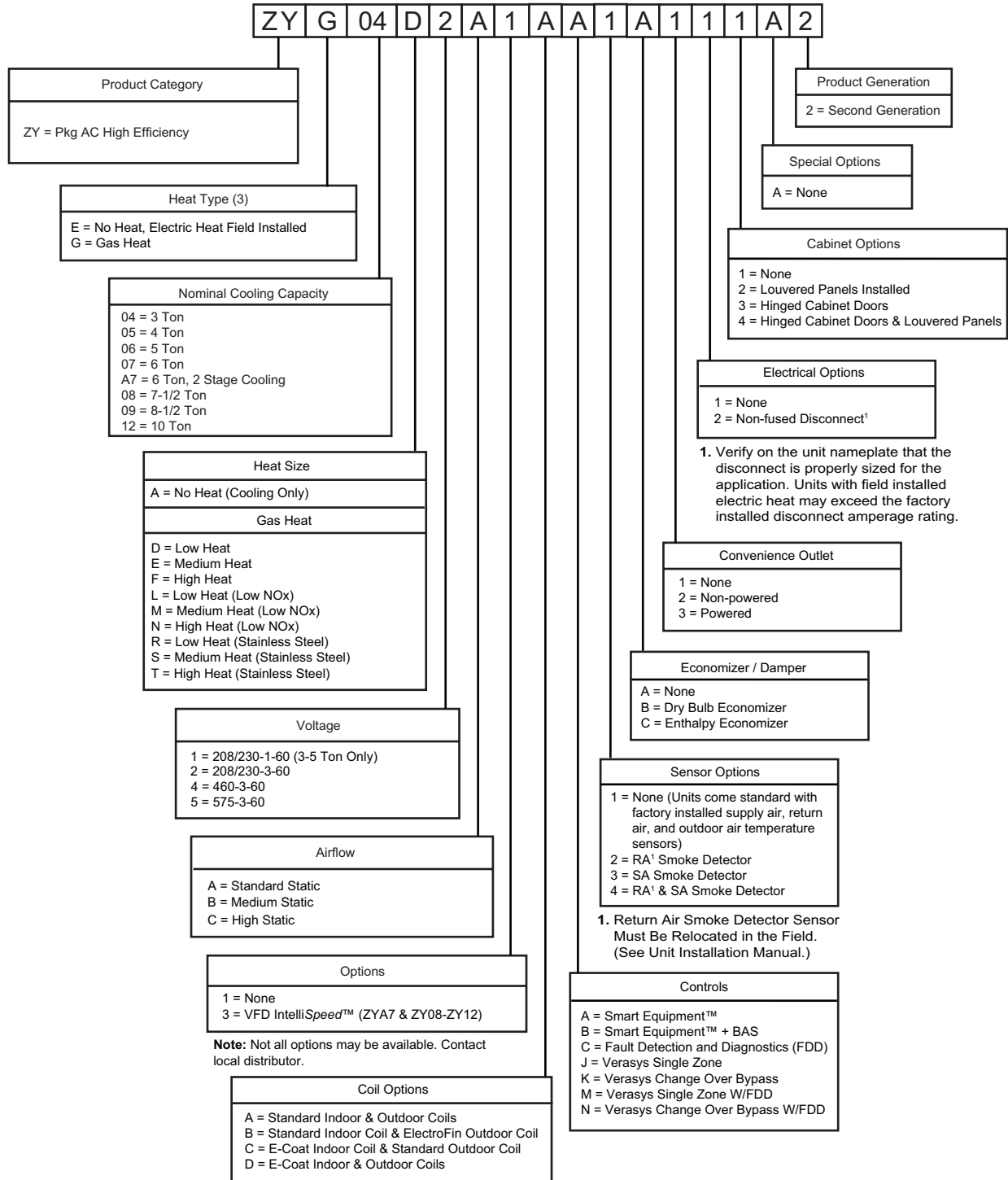
Improper installation may create a condition where the operation of the product could cause personal injury or property damage.

### CAUTION

This system uses R-410A Refrigerant which operates at higher pressures than R-22. No other refrigerant may be used in this system.

Nomenclature

3-10 Ton Model Number Nomenclature



## Installation

### Installation Safety Information

Read these instructions before continuing this appliance installation. This is an outdoor combination heating and cooling unit. The installer must assure that these instructions are made available to the consumer and with instructions to retain them for future reference.

1. Refer to the unit rating plate for the approved type of gas for this product.
2. Install this unit only in a location and position as specified on Page 6 of these instructions.
3. Never test for gas leaks with an open flame. Use commercially available soap solution made specifically for the detection of leaks when checking all connections, as specified on Pages 5, 66, 66 and 96 of these instructions.
4. Always install furnace to operate within the furnace's intended temperature-rise range with the duct system and within the allowable external static pressure range, as specified on the unit name/rating plate, specified in Table 10 of these instructions.
5. This equipment is not to be used for temporary heating of buildings or structures under construction.

### WARNING

#### FIRE OR EXPLOSION HAZARD

Failure to follow the safety warning exactly could result in serious injury, death or property damage.

Never test for gas leaks with an open flame. Use a commercially available soap solution made specifically for the detection of leaks to check all connections. A fire or explosion may result causing property damage, personal injury or loss of life.

### Preceding Installation

1. Remove the two screws holding the brackets in the side fork-lift slots.



**Figure 1: Unit Shipping Bracket**

2. Turn each bracket toward the ground and the protective plywood covering will drop to the ground.
3. Remove the condenser coil external protective covering prior to operation.



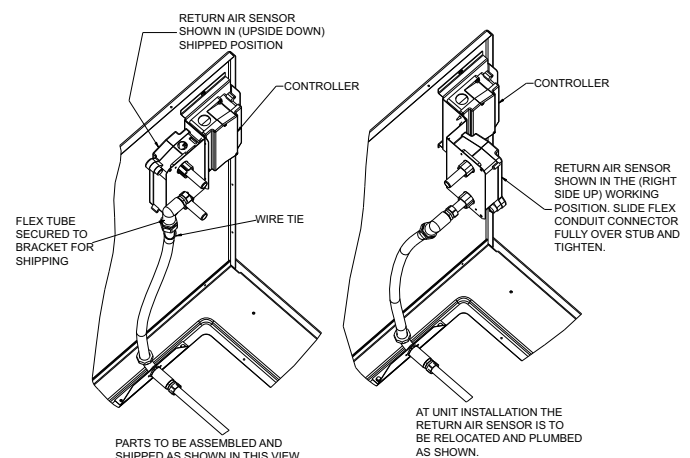
**Figure 2: Condenser Covering**

4. If a factory option convenience outlet is installed, the weatherproof outlet cover must be field installed. The cover shall be located behind the filter access panel. To install the cover, remove the shipping label covering the convenience outlet, follow the instructions on the back of the weatherproof cover box, and attach the cover to the unit using the (4) screws provided.

### CAUTION

208/230-3-60 and units with factory installed Powered Convenience Outlet Option are wired for 230v power supply. Change tap on transformer for 208-3-60 operation. See unit wiring diagram.

5. If a factory option return air smoke detector is installed, the return air sensor must be moved from a factory shipped (upside down) position to the (right side up) working position and the flex conduit sampler tube connected.



**Figure 3: Return Air Smoke Detector Field Location**

**Limitations**

These units must be installed in accordance with the following:

In U.S.A.:

1. National Electrical Code, ANSI/NFPA No. 70 - Latest Edition
2. National Fuel Gas Code, ANSI Z223.1 - Latest Edition
3. Gas-Fired Central Furnace Standard, ANSI Z21.47a. - Latest Edition
4. Local building codes, and
5. Local gas utility requirements

In Canada:

1. Canadian Electrical Code, CSA C22.1
2. Installation Codes, CSA - B149.1.

3. Local plumbing and waste water codes, and
4. Other applicable local codes.

Refer to unit application data found in this document.

After installation, gas fired units must be adjusted to obtain a temperature rise within the range specified on the unit rating plate.

If components are to be added to a unit to meet local codes, they are to be installed at the dealer's and/or customer's expense.

Size of unit for proposed installation should be based on heat loss/heat gain calculation made according to the methods of Air Conditioning Contractors of America (ACCA).

This furnace is not to be used for temporary heating of buildings or structures under construction.

**Table 1: ZY04-12 Unit Limitations**

Model	Size (Tons)	Unit Voltage	Unit Limitations		
			Applied Voltage		Outdoor DB Temp
			Min	Max	Max (°F)
ZY	04 (3)	208/230-1-60	187	252	125
		208/230-3-60	187	252	125
		460-3-60	432	504	125
		575-3-60	540	630	125
ZY	05 (4)	208/230-1-60	187	252	125
		208/230-3-60	187	252	125
		460-3-60	432	504	125
		575-3-60	540	630	125
ZY	06 (5)	208/230-1-60	187	252	125
		208/230-3-60	187	252	125
		460-3-60	432	504	125
		575-3-60	540	630	125
ZY	07 (6)	208/230-3-60	187	252	125
		460-3-60	432	504	125
		575-3-60	540	630	125
		208/230-3-60	187	252	125
ZY	A7 (6)	460-3-60	432	504	125
		575-3-60	540	630	125
		208/230-3-60	187	252	125
		460-3-60	432	504	125
ZY	08 (7.5)	575-3-60	540	630	125
		208/230-3-60	187	252	125
		460-3-60	432	504	125
		575-3-60	540	630	125
ZY	09 (8.5)	208/230-3-60	187	252	125
		460-3-60	432	504	125
		575-3-60	540	630	125
		208/230-3-60	187	252	125
ZY	12 (10)	460-3-60	432	504	125
		575-3-60	540	630	125
		208/230-3-60	187	252	125
		460-3-60	432	504	125

**Location**

Use the following guidelines to select a suitable location for these units:

1. Unit is designed for *outdoor installation only*.
2. Condenser coils must have an unlimited supply of air. Where a choice of location is possible, position the unit on either north or east side of building.
3. Suitable for mounting on roof curb.

4. For ground level installation, use a level concrete slab with a minimum thickness of 4 inches. The length and width should be at least 6 inches greater than the unit base rails. Do not tie slab to the building foundation.
5. Roof structures must be able to support the weight of the unit and its options/accessories. Unit must be installed on a solid, level roof curb or appropriate angle iron frame.
6. Maintain level tolerance to 1/2" across the entire width and length of unit.

**▲ WARNING**

Excessive exposure of this furnace to contaminated combustion air will result in safety and performance related problems. Typical contaminants include: permanent wave solution, chlorinated waxes and cleaners, chlorine based swimming pool chemicals, water softening chemicals, de-icing salts or chemicals, carbon tetrachloride, Halogen type refrigerants, cleaning solvents (e.g. perchloroethylene), printing inks, paint removers, varnishes, hydrochloric acid, cements and glues, anti-static fabric softeners for clothes dryers, masonry acid washing materials.

**Clearances**

All units require particular clearances for proper operation and service. Installer must make provisions for adequate combustion and ventilation air in accordance with section 5.3 of Air for Combustion and Ventilation of the National Fuel Gas Code, ANSI Z223.1 – Latest Edition (in U.S.A.), or Sections 7.2, 7.3, or 7.4 of Gas Installation Codes, CSA-B149.1 (in Canada) - Latest Edition, and/or applicable provisions of the local building codes. Refer to Tables 4 and 5 for clearances required for combustible construction, servicing, and proper unit operation.

**▲ WARNING**

Do not permit overhanging structures or shrubs to obstruct condenser air discharge outlet, combustion air inlet or vent outlets.

**Rigging And Handling**

Exercise care when moving the unit. Do not remove any packaging until the unit is near the place of installation. Rig the unit by attaching chain or cable slings to the lifting holes provided in the base rails. Spreader bars, whose length exceeds the largest dimension across the unit, **MUST** be used across the top of the unit.

**▲ CAUTION**

If a unit is to be installed on a roof curb other than a UP roof curb, gasketing must be applied to all surfaces that come in contact with the unit underside.

**▲ CAUTION**

Before lifting, make sure the unit weight is distributed equally on the rigging cables so it will lift evenly.

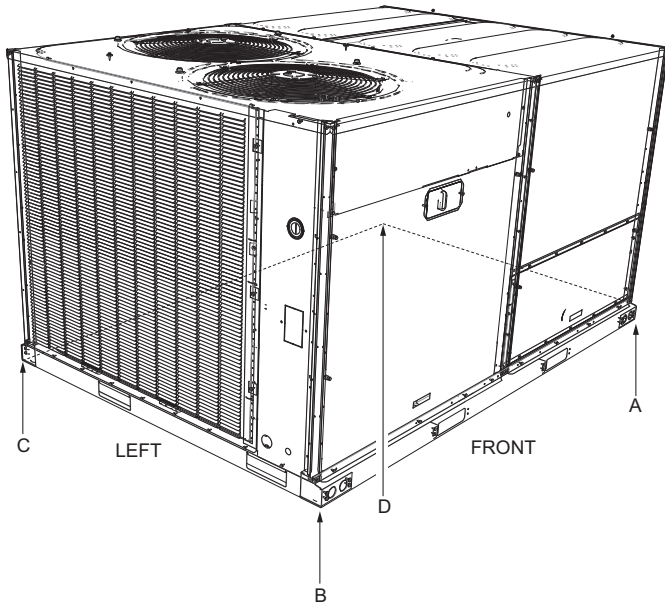
Units may be moved or lifted with a forklift. Slotted openings in the base rails are provided for this purpose.

**LENGTH OF FORKS MUST BE A MINIMUM OF 60 INCHES.**

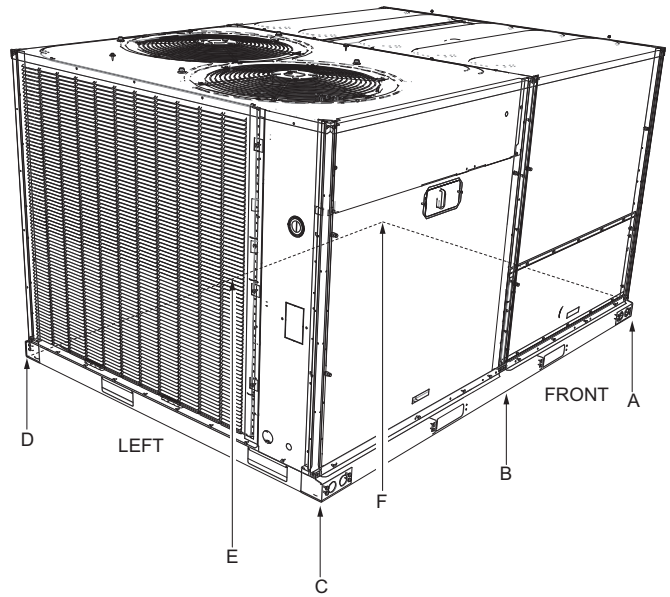
**▲ CAUTION**

All panels must be secured in place when the unit is lifted.  
The condenser coils should be protected from rigging cable damage with plywood or other suitable material.

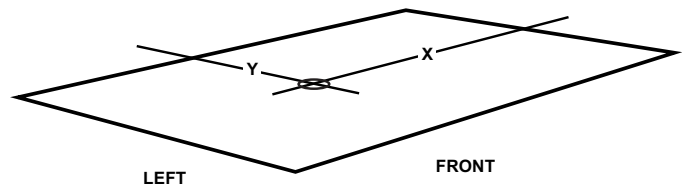
**ZY04-12 Unit Weights**



**Figure 4: Unit 4 Point Load Weight**



**Figure 5: Unit 6 Point Load Weight**



**Figure 6: Center of Gravity**

**Table 2: ZY04-12 Corner Weights**

Model	Size (Tons)	Weight (lbs.)		Center of Gravity		4 Point Load Location (lbs.)				6 Point Load Location (lbs.)					
		Shipping	Operating	X	Y	A	B	C	D	A	B	C	D	E	F
ZYE	04 (3)	486	481	36	25	127	118	113	122	86	82	78	75	78	82
ZYE	05 (4)	569	564	36	25	145	140	137	142	97	95	93	91	93	95
ZYE	06 (5)	587	582	36	25	151	145	140	146	101	99	96	93	95	98
ZYE	07 (6)	739	734	44	36	208	213	158	154	138	140	143	106	104	103
ZYE	A7 (6)	849	829	45.0	35.3	229	244	183	172	151	158	165	124	118	113
ZYE	08 (7.5)	883	878	46	36	239	271	196	173	156	169	184	133	122	113
ZYE	09 (8.5)	878	878	46	36	241	265	195	177	158	168	180	132	124	116
ZYE	12 (10)	907	902	47	36	239	278	207	178	155	171	190	142	128	116
ZYG	04 (3)	532	527	36	27	147	136	117	126	99	94	90	77	81	85
ZYG	05 (4)	623	618	36	26	167	156	142	152	113	108	103	94	98	103
ZYG	06 (5)	641	636	35	26	174	159	144	159	118	111	104	95	101	108
ZYG	07 (6)	809	804	43	37	240	236	163	166	161	159	157	108	109	111
ZYG	A7 (6)	919	899	45.0	35.3	249	265	199	187	164	171	179	134	128	123
ZYG	08 (7.5)	985	980	44	37	290	297	199	195	192	195	198	133	131	129
ZYG	09 (8.5)	980	980	45	36	279	292	209	200	184	190	196	141	136	132
ZYG	12 (10)	1013	1008	45	36	285	300	217	206	189	195	202	146	141	136



**Table 3: ZY04-12 Unit Accessory Weights**

<b>Unit Accessory</b>	<b>Weights (lbs.)</b>
Vertical Flow Dry Bulb Economizer Small Footprint	55
Vertical Flow Dry Bulb Economizer Large Footprint	60
Horizontal Flow Dry Bulb Economizer Small Footprint Short	74
Horizontal Flow Dry Bulb Economizer Small Footprint Tall	76
Horizontal Flow Dry Bulb Economizer Large Footprint Short	79
Horizontal Flow Dry Bulb Economizer Large Footprint Tall	82
Power Exhaust Vert Flow Small Footprint	55
Power Exhaust Vert Flow Large Footprint	75
Power Exhaust Horiz Flow Small Footprint	40
Power Exhaust Horiz Flow Large Footprint	80
Hail Guard Kit Small Short Factory Installed	18
Hail Guard Kit Small Tall Factory Installed	23
Hail Guard Kit Large Short Factory Installed	36
Hail Guard Kit Large Tall Factory Installed	44
Flue Extension Kit (1FE0414)	15
Flue Extension Kit (1FE0415)	17
Flue Extension Kit (1FE0416)	20
Curb Rigid 14" Small Footprint	94
Curb Rigid 14" Large Footprint	126
Curb Rigid 24" Small Footprint	148
Curb Rigid 24" Large Footprint	222

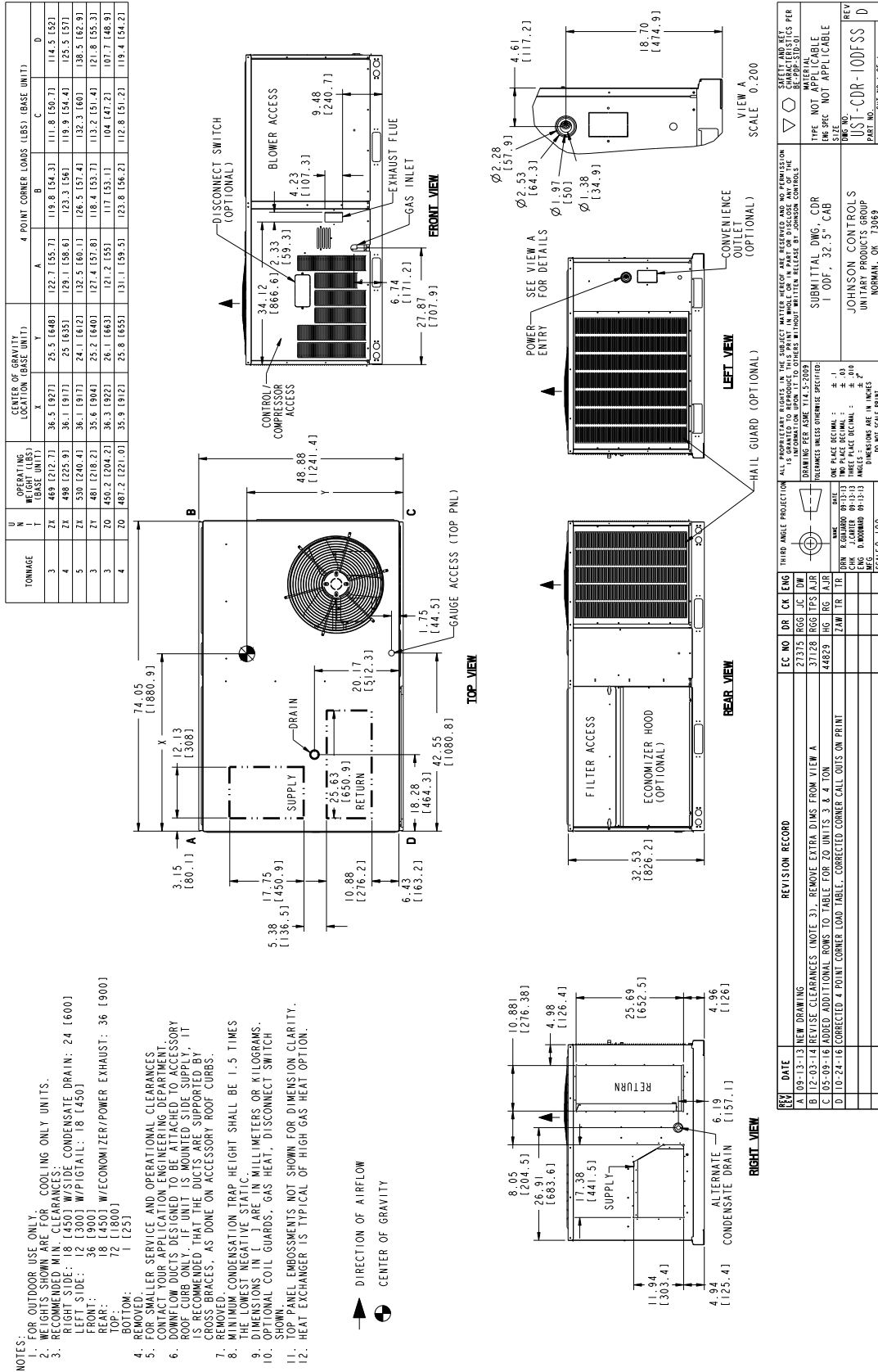
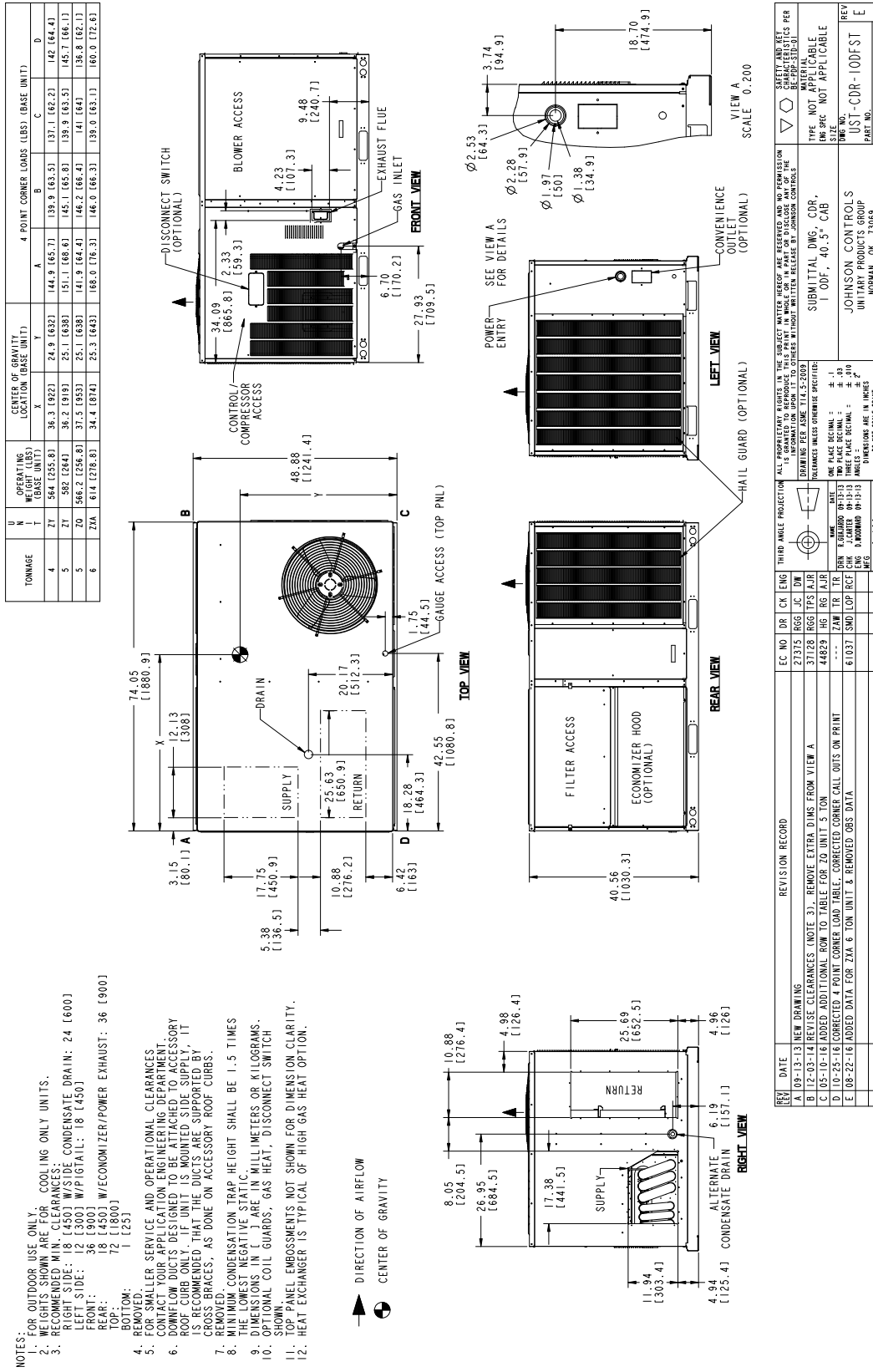


Figure 7: ZY04 Unit Dimensions



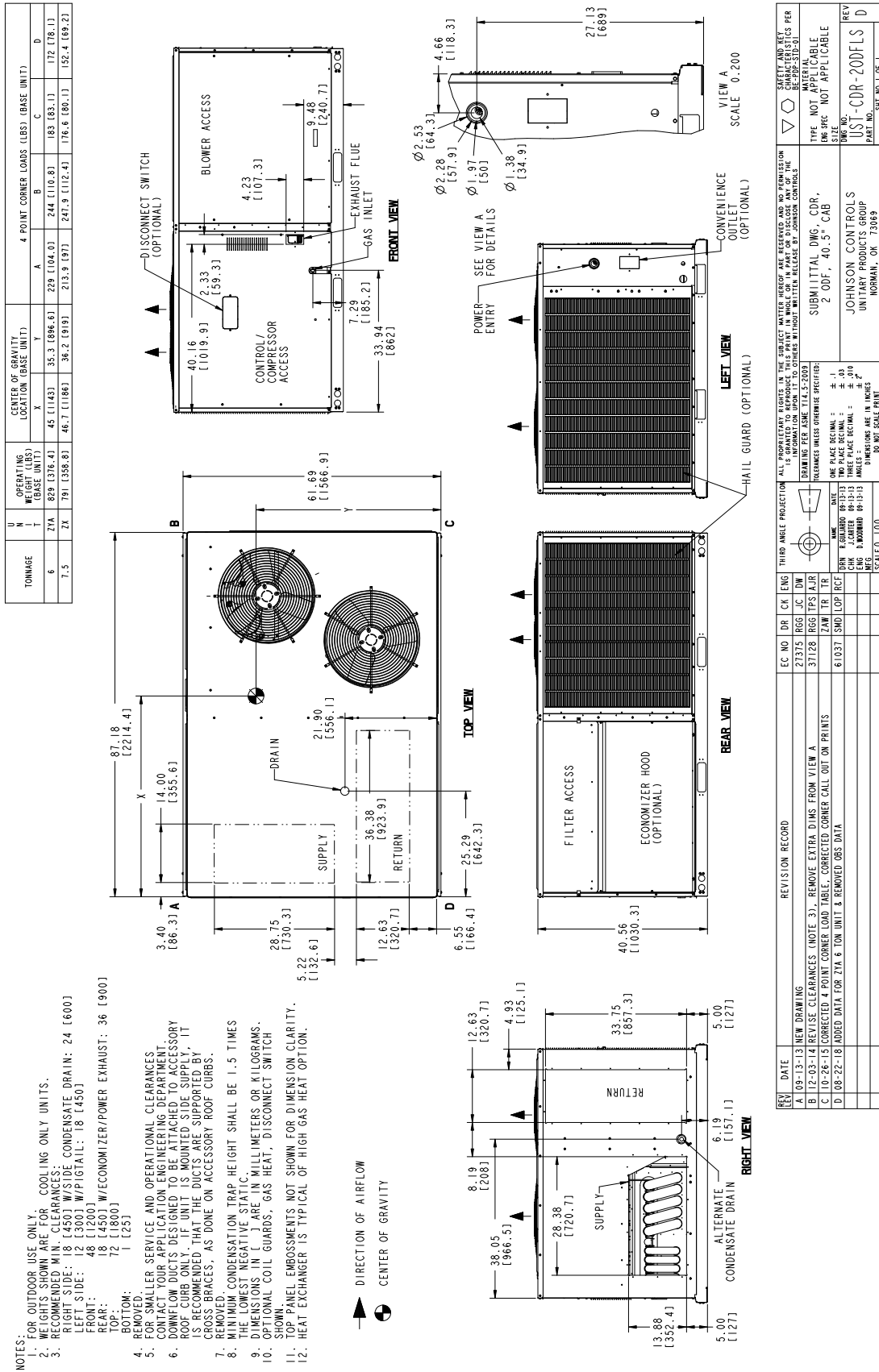
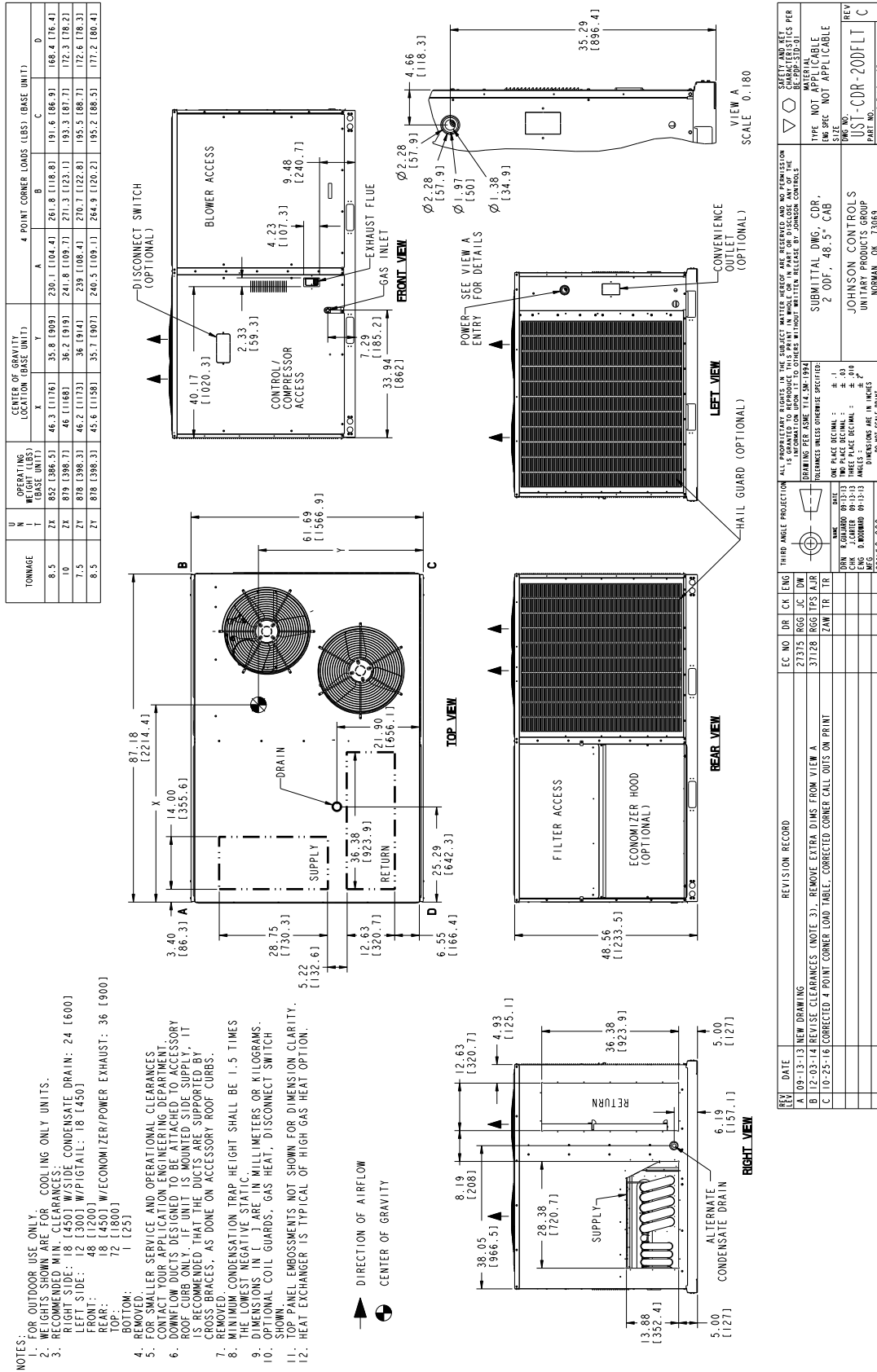


Figure 9: ZY07 and ZYA7 Unit Dimensions





**Table 4: ZY04-06 Unit Clearances**

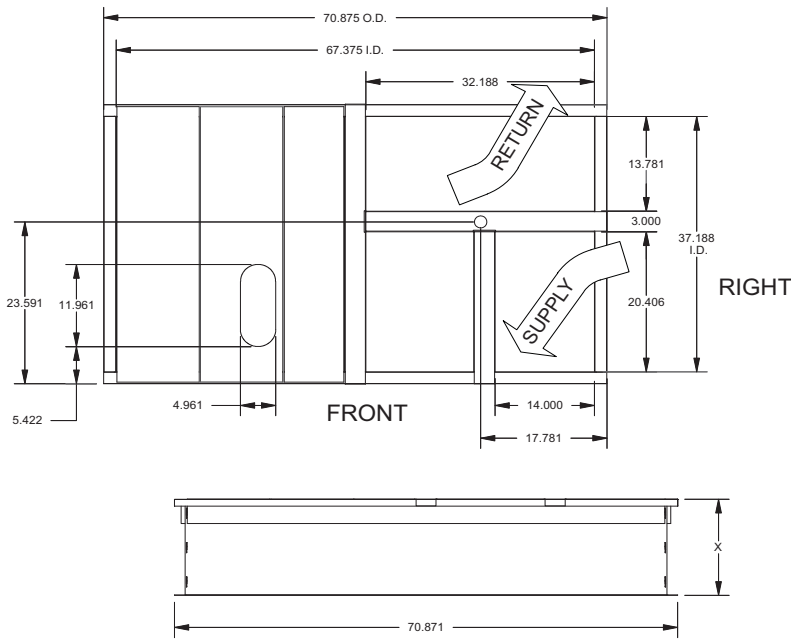
Direction	Distance (in.)	Direction	Distance (in.)
Top <sup>1</sup>	72	Right	18
Front	36	Left	12
Rear	18 <sup>2</sup> /36 <sup>3</sup>	Bottom <sup>4</sup>	1

1. Units must be installed outdoors. Over hanging structure or shrubs should not obscure condenser air discharge outlet.
2. Units without economizer or power exhaust.
3. Units equipped with an Economizer or Power Exhaust. Flue products must not be discharged within 10 Feet of the rear of the unit.
4. Units may be installed on combustible floors made from wood or class A, B or C roof covering materials.

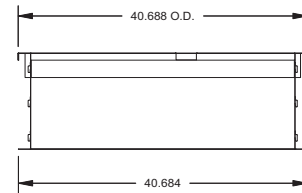
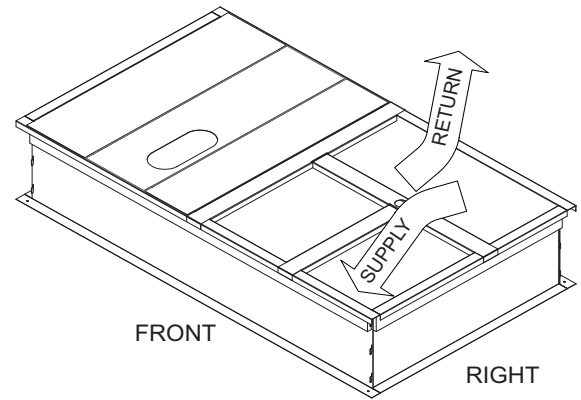
**Table 5: ZYA7 and ZY07-12 Unit Clearances**

Direction	Distance (in.)	Direction	Distance (in.)
Top <sup>1</sup>	72	Right	18
Front	48	Left	12
Rear	18 <sup>2</sup> /36 <sup>3</sup>	Bottom <sup>4</sup>	1

1. Units must be installed outdoors. Over hanging structure or shrubs should not obscure condenser air discharge outlet.
2. Units without economizer or power exhaust.
3. Units equipped with an Economizer or Power Exhaust. Flue products must not be discharged within 10 Feet of the rear of the unit.
4. Units may be installed on combustible floors made from wood or class A, B or C roof covering materials.



1RC0456 X= 14" Height  
 1RC0458 X= 24" Height



**Notes:**

1. Sides, ends and cross support are 18-G90. Deck pans, R/A & S/A supports are 20-G90.
2. Full perimeter wood nailer.
3. Insulated deck pans.

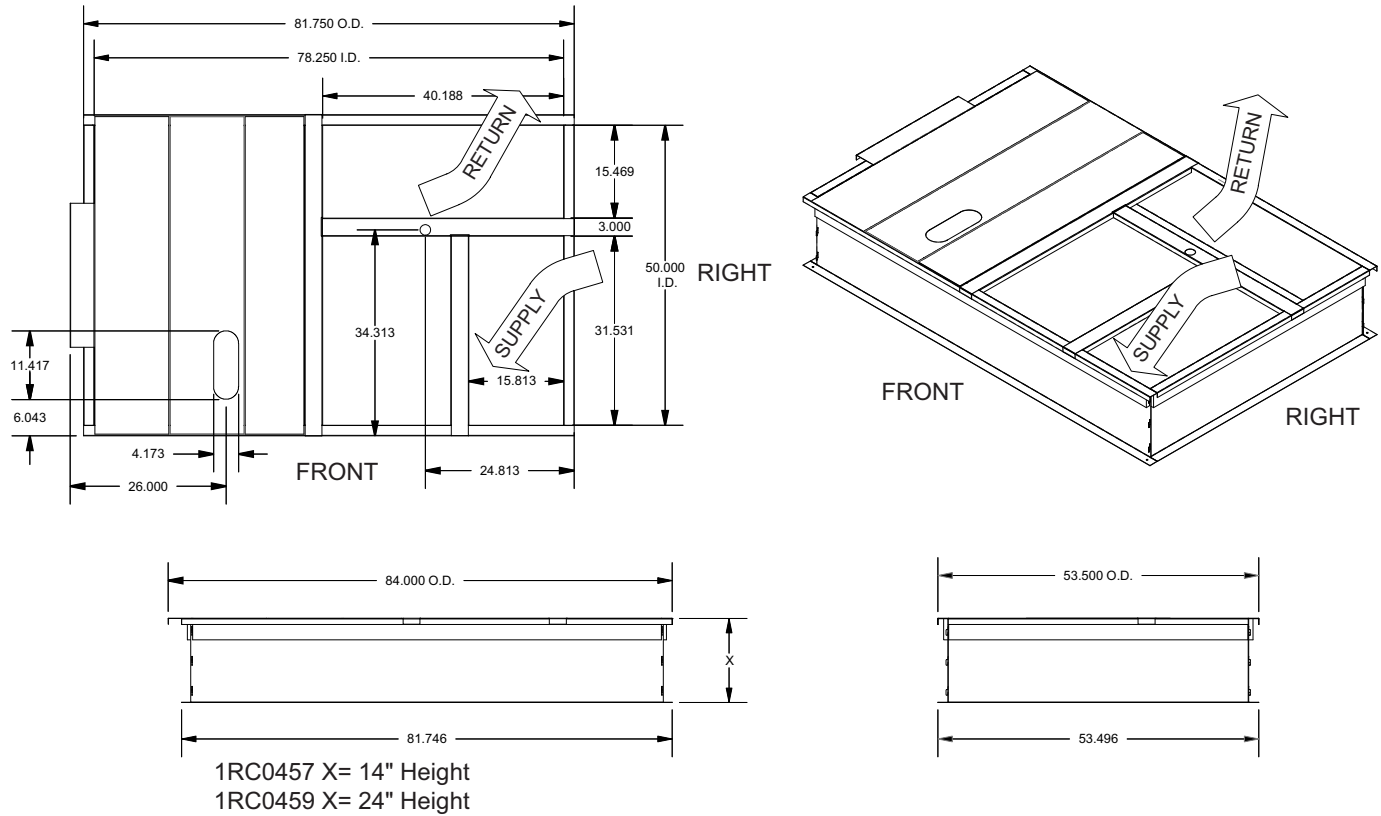
**Figure 12: 1RC0456, 1RC0458 Roof Curb Dimensions**

**Table 6: Unit Models used with 1RC0456, 1RC0458 Roof Curb**

ZY04
ZY05
ZY06

**NOTE:** If utilities are required thru the base of the unit or thru the roof curb the following field installed accessories can be purchased thru your dealer or contractor:

- 1TB0401 - Thru the base electrical and thru the curb gas
- 1TB0403 - Thru the base electrical and gas



**Notes:**

1. Sides, ends, unit locator and cross support are 18-G90. Deck pans, R/A & S/A supports are 20-G90.
2. Full perimeter wood nailer.
3. Insulated deck pans.

**Figure 13: 1RC0457, 1RC0459 Roof Curb Dimensions**

**Table 7: Unit Models used with 1RC0457, 1RC0459 Roof Curb**

ZY07
ZYA7
ZY08
ZY09
ZY12

**NOTE:** If utilities are required thru the base of the unit or thru the roof curb the following field installed accessories can be purchased thru your dealer or contractor:

- 1TB0401 - Thru the base electrical and thru the curb gas
- 1TB0403 - Thru the base electrical and gas

**Ductwork**

Ductwork should be designed and sized according to the methods in Manual D of the Air Conditioning Contractors of America (ACCA) or as recommended by any other recognized authority such as ASHRAE or SMACNA.

A closed return duct system should be used. This will not preclude use of economizers or outdoor fresh air intake. The supply and return air duct connections at the unit should be made with flexible joints to minimize noise.

The supply and return air duct systems should be designed for the CFM and static pressure requirements of the job. They

should NOT be sized to match the dimensions of the duct connections on the unit.

Refer to Figures 7 thru 11 for bottom and side air duct openings.

**Duct Covers**

Units are shipped with the side duct openings covered and a covering over the bottom of the unit. For bottom duct application, Models and ZY07 require a filler plate to be removed from the return air opening, for all other models no



other changes are necessary. For side duct application, remove the side duct covers and install over the bottom duct openings. The panels removed from the side duct connections are designed to be reused by securing each panel to its respective bottom duct opening. But keep in mind that the supply and return panels are installed with the painted surface DOWN, facing the bottom duct opening. The gasket must be removed from the insulation side of the duct cover so it is not directly exposed to the heating elements. The panels are secured by sliding them into slots in the back of the duct openings and screwing them to the base of the unit with screws (Use screws removed from original panel location.). Seals around duct openings must be tight.

### CAUTION

When fastening ductwork to side duct flanges on unit, insert screws through duct flanges only. DO NOT insert screws through casing. Outdoor ductwork must be insulated and water-proofed.



**Figure 14: Side Duct Cover Panels**

**NOTE:** Shown with duct connection cover panel as shipped.



**Figure 15: Bottom Return Opening For Side Duct Conversion**

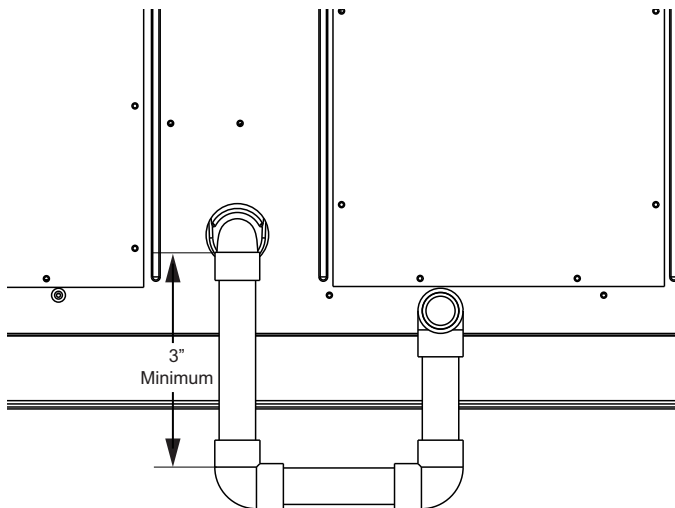


**Figure 16: Bottom Supply Opening For Side Duct Conversion**

### Condensate Drain

A side condensate drain is provided to facilitate condensate piping. A condensate drain connection is available through the base pan for piping inside the roof curb. Trap the connection per Figure 17. The trap and drain lines should be protected from freezing.

Plumbing must conform to local codes. Use a sealing compound on male pipe threads. Install condensate drain line from the 3/4 inch NPT female connection on the unit to an open drain.



**Figure 17: Condensate Drain**

## Compressors

The compressor used in this product is specifically designed to operate with R-410A Refrigerant and cannot be interchanged.

### CAUTION

This system uses R-410A Refrigerant which operates at higher pressures than R-22. No other refrigerant may be used in this system.

The compressor also uses a refrigerant oil that is extremely hygroscopic, meaning it absorbs water readily. They can absorb 15 times as much water as other oils designed for HCFC and CFC refrigerants. Take all necessary precautions to avoid exposure of the oil to the atmosphere.

### CAUTION

Do not leave the system open to the atmosphere. Unit damage could occur due to moisture being absorbed by the **refrigerant** in the system. This type of oil is highly susceptible to moisture absorption.

R-410A compressor lubricants are known to cause long term damage to some synthetic roofing materials.

### CAUTION

Exposure, even if immediately cleaned up, may cause embrittlement (leading to cracking) to occur in one year or more. When performing any service that may risk exposure of compressor oil to the roof, take precautions to protect roofing.

Procedures which risk oil leakage include, but are not limited to, compressor replacement, repairing refrigerant leaks, replacing refrigerant components such as filter drier, pressure switch, metering device or coil.

Units are shipped with compressor mountings which are factory-adjusted and ready for operation.

### CAUTION

Do not loosen compressor mounting bolts.

## Filters

Two-inch filters are supplied with each unit. Four-inch filters may be used with no modification to the filter racks. Filters must always be installed ahead of evaporator coil and must be kept clean or replaced with same size and type. Dirty filters reduce the capacity of the unit and result in frosted coils or safety shutdown. Refer to physical data tables, for the number and size of filters needed for the unit. The unit should not be operated without filters properly installed.

## Power And Control Wiring

Field wiring to the unit, fuses, and disconnects must conform to provisions of National Electrical Code (NEC), ANSI/NFPA No. 70 – Latest Edition (in U.S.A.), current Canadian Electrical Code C221, and/or local ordinances. The unit must be electrically grounded in accordance with NEC and CEC as specified above and/or local codes.

Voltage tolerances which must be maintained at the compressor terminals during starting and running conditions are indicated on the unit Rating Plate and Table 1.

### CAUTION

208/230-3-60 and 208/230-1-60 units control transformers are factory wired for 230v. Change tap on transformer for 208v operation. See unit wiring diagram.

The internal wiring harnesses furnished with this unit are an integral part of the design certified unit. Field alteration to comply with electrical codes should not be required. If any of the wire supplied with the unit must be replaced, replacement wire must be of the type shown on the wiring diagram and the same minimum gauge as the replaced wire.

A disconnect must be utilized for these units. Factory installed disconnects are available. If installing a disconnect (field supplied), refer to Figures 7 thru 11 for the recommended mounting location.

**⚠ CAUTION**

Avoid damage to internal components if drilling holes for disconnect mounting.

**NOTE:** Since not all local codes allow the mounting of a disconnect on the unit, please confirm compliance with local code before mounting a disconnect on the unit.

Electrical line must be sized properly to carry the load. USE COPPER CONDUCTORS ONLY. Each unit must be wired with a separate branch circuit fed directly from the meter panel and properly fused.

**⚠ CAUTION**

When connecting electrical power and control wiring to the unit, water-proof connectors must be used so that water or moisture cannot be drawn into the unit during normal operation. The above water-proofing conditions will also apply when installing a field supplied disconnect switch.

**⚠ CAUTION**

When installing equipment in a facility with a 3 phase high-leg delta power supply, care must be taken to ensure that the high-leg conductor is not attached to either of the two legs of the (single phase, direct drive) X13 or ECM motors. Failure to do so can result in the motor acting erratically or not running at all.

Check for the high leg conductor by checking voltage of each phase to ground.

Example: A or L1 phase to ground, voltage reading is 120V. B or L2 phase to ground, voltage reading is 195 to 208V. C or L3 phase to ground, voltage reading is 120V. Therefore B or L2 phase is the high Leg. The high should always be wired to the center or B or L2 tap.

**Note:** Check all three phase motors and compressors for proper rotation after making a change. If it is necessary to change 3 phase motor rotation, swap A or L1 and C or L3 only.

**Thermostat Wiring**

A two stage thermostat must be used and should be located on an inside wall approximately 56 inch above the floor where it will not be subject to drafts, sun exposure or heat from electrical fixtures or appliances. Follow the manufacturer's instructions enclosed with thermostat for general installation procedure. Eight (8) color-coded, insulated wires should be used to connect the thermostat to the unit. Refer to Table 8 for control wire sizing and maximum length.

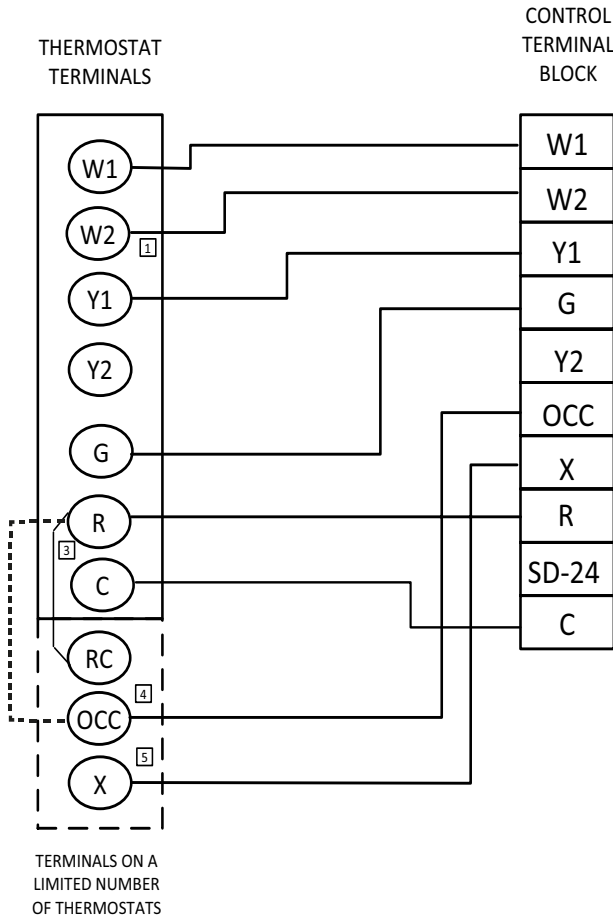
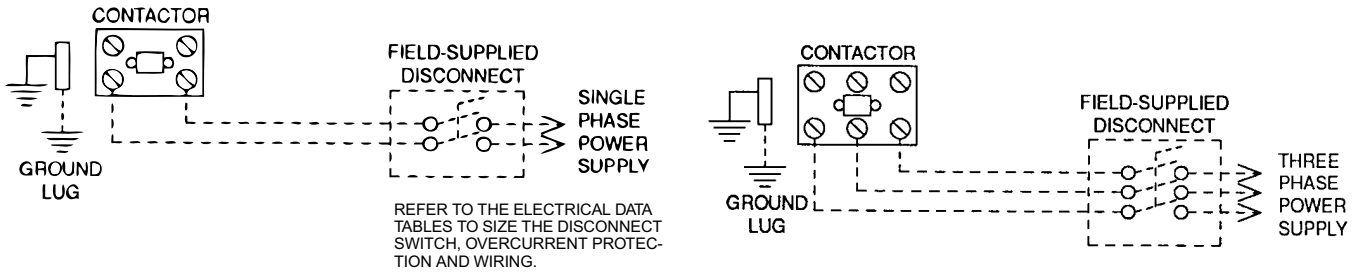
**Table 8: Control Wire Sizes**

Wire Size	Maximum Length <sup>1</sup>
18 AWG	150 Feet

1. From the unit to the thermostat and back to the unit.

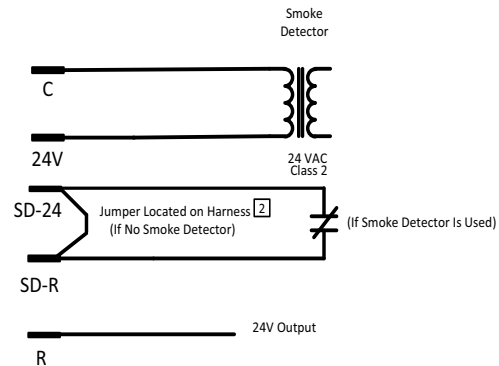
# Typical Field Power and Control Wiring

## Typical Power Wiring



### R~Occ Jumper:

Smart Equipment Control boards come from the factory with a jumper wire between R and OCC terminals on the thermostat terminal strip. Failure to remove this jumper will place the unit into the Occupied mode no matter what the occupancy demand is from the thermostat or EMS system. To allow Thermostat or EMS control of the Occupied mode for the unit, this jumper must be removed during commissioning.



- 1 Second stage heating not required on single stage heating units.
- 2 Jumper is required if there is no Smoke Detector circuit.
- 3 Jumper is required for any combination of R, RC, or RH.
- 4 OCC is an output from the thermostat to indicate the Occupied condition.
- 5 X is an input to the thermostat to display Error Status conditions.

**Figure 18: Typical Smart Equipment™ Control Wiring**

Table 9: Electrical Data

ZYE04-12 Standard Static Indoor Blower - Without Powered Convenience Outlet

Size (Tons)	Nominal Unit Voltage	Compressor 1			Compressor 2			OD Fan Motors (each)	Supply Blower Motor	Pwr Exh Motor	Pwr Conv Outlet	Electric Heat Field Installed Kit 2EK045*				MCA <sup>1</sup> (Amps)	Min Fuse <sup>2/</sup> Breaker <sup>3</sup> Size (Amps)	Max Fuse <sup>2/</sup> Breaker <sup>3</sup> Size (Amps)	Min Disconnect Rating <sup>4</sup>		MCA <sup>1</sup> w/Pwr Exh (Amps)	Min Fuse <sup>2/</sup> Breaker <sup>3</sup> Size w/ Pwr Exh (Amps)	Max Fuse <sup>2/</sup> Breaker <sup>3</sup> Size w/ Pwr Exh (Amps)	Min Disconnect Rating <sup>4</sup> / Pwr Exh			
		RLA	LRA	MCC	RLA	LRA	MCC					Model	kW	Stages	Amps				FLA	LRA				FLA	LRA		
04 (3)	208-1-60	16.7	79	26				1.4	6.6	1.5		None	-	-	-	28.9	30	45	28	84	30.4	35	45	30	88		
												10625	4.9	1	23.6	37.8	40	45	35	84	39.6	40	45	36	88		
												11125	7.9	1	38	55.8	60	60	51	84	57.6	60	60	53	88		
	230-1-60	16.7	79	26				1.4	6	1.3			None	-	-	-	28.3	30	40	28	84	29.6	30	45	29	87	
													10625	6.5	1	27.1	41.4	45	45	38	84	43	45	45	40	87	
													11125	10.5	1	43.8	62.3	70	70	57	84	63.9	70	70	59	87	
	208-3-60	10.4	73	16				1.4	6.6	1.1			None	-	-	-	21	25	30	21	78	22.1	25	30	22	81	
													10625	4.9	1	13.6	25.3	30	30	23	78	26.6	30	30	24	81	
													11125	7.9	1	21.9	35.6	40	40	33	78	37	40	40	34	81	
	230-3-60	10.4	73	16				1.4	6	1			None	-	-	-	20.4	25	30	20	78	21.4	25	30	22	81	
													10625	6.5	1	15.6	27	30	30	25	78	28.3	30	30	26	81	
													11125	10.5	1	25.3	39.1	40	40	36	78	40.4	45	45	37	81	
	460-3-60	5.8	38	9				0.8	3.2	0.5			None	-	-	-	11.3	15	15	11	42	11.8	15	15	12	43	
													10646	6	1	7.2	13	15	15	12	42	13.6	15	15	13	43	
													11146	11.5	1	13.8	21.3	25	25	20	42	21.9	25	25	20	43	
	575-3-60	3.8	36.5	6				0.6	6	0.4			None	-	-	-	7.8	15	15	8	39	8.2	15	15	8	40	
													11058	9.2	1	8.9	14.1	15	15	13	39	14.6	15	15	13	40	
													11458	13.8	1	13.3	19.6	20	20	18	39	20.1	25	25	19	40	
	05 (4)	208-1-60	21.8	117	34				1.4	8.4	1.5		None	-	-	-	37.1	40	50	36	122	38.6	40	60	38	126	
													10625	4.9	1	23.6	40	40	50	37	122	41.9	45	60	39	126	
													11125	7.9	1	38	58	60	60	53	122	59.9	60	60	55	126	
		230-1-60	21.8	117	34				1.4	7.6	1.3			None	-	-	-	36.3	40	50	35	122	37.6	40	50	37	125
														10625	6.5	1	27.1	43.4	45	50	40	122	45	45	50	41	125
														11125	10.5	1	43.8	64.3	70	70	59	122	65.9	70	70	61	125
208-3-60		13.7	83.1	21				1.4	8.4	1.1			None	-	-	-	26.9	30	40	27	88	28	30	40	28	91	
													10625	4.9	1	13.6	27.5	30	40	27	88	28.9	30	40	28	91	
													11125	7.9	1	21.9	37.9	40	40	35	88	39.3	40	40	36	91	
230-3-60		13.7	83.1	21				1.4	7.6	1			None	-	-	-	26.1	30	35	26	88	27.1	30	40	27	91	
													10625	6.5	1	15.6	29	30	35	27	88	30.3	35	40	28	91	
													11125	10.5	1	25.3	41.1	45	45	38	88	42.4	45	45	39	91	
460-3-60		6.2	41	10				0.8	4	0.5			None	-	-	-	12.6	15	15	13	45	13.1	15	15	13	46	
													10646	6	1	7.2	14	15	15	13	45	14.6	15	15	13	46	
													11146	11.5	1	13.8	22.3	25	25	20	45	22.9	25	25	21	46	
575-3-60		4.8	33	8				0.6	7.6	0.4			None	-	-	-	9.6	15	15	10	35	10	15	15	10	36	
													11058	9.2	1	8.9	14.9	15	15	14	35	15.4	20	20	14	36	
													11458	13.8	1	13.3	20.4	25	25	19	35	20.9	25	25	19	36	

ZYE04-12 Standard Static Indoor Blower - Without Powered Convenience Outlet (Continued)

Size (Tons)	Nominal Unit Voltage	Compressor 1			Compressor 2			OD Fan Motors (each)	Supply Blower Motor	Pwr Exh Motor	Pwr Conv Outlet	Electric Heat Field Installed Kit 2EK045*				MCA <sup>1</sup> (Amps)	Min Fuse <sup>2</sup> / Breaker <sup>3</sup> Size (Amps)	Max Fuse <sup>2</sup> / Breaker <sup>3</sup> Size (Amps)	Min Disconnect Rating <sup>4</sup>		MCA <sup>1</sup> w/Pwr Exh (Amps)	Min Fuse <sup>2</sup> / Breaker <sup>3</sup> Size w/ Pwr Exh (Amps)	Max Fuse <sup>2</sup> / Breaker <sup>3</sup> Size w/ Pwr Exh (Amps)	Min Disconnect Rating <sup>4</sup> / Pwr Exh			
		RLA	LRA	MCC	RLA	LRA	MCC					Model	kW	Stages	Amps				FLA	LRA				FLA	LRA		
06 (5)	208-1-60	25	134	39				2.3	8.4	1.5		None	-	-	-	42	45	60	41	141	43.5	45	60	43	144		
												10625	4.9	1	23.6	42	45	60	41	141	43.5	45	60	43	144		
												11125	7.9	1	38	58	60	60	53	141	59.9	60	60	55	144		
	230-1-60	25	134	39				2.3	7.6	1.3			None	-	-	-	41.2	45	60	40	141	42.5	45	60	42	144	
													10625	6.5	1	27.1	43.4	45	60	40	141	45	45	60	42	144	
													11125	10.5	1	43.8	64.3	70	70	59	141	65.9	70	70	61	144	
	208-3-60	15.9	110	25				2.3	8.4	1.1			None	-	-	-	30.6	35	45	31	117	31.7	35	45	32	119	
													10625	4.9	1	13.6	30.6	35	45	31	117	31.7	35	45	32	119	
													11125	7.9	1	21.9	37.9	40	45	35	117	39.3	40	45	36	119	
	230-3-60	15.9	110	25				2.3	7.6	1			None	-	-	-	29.8	30	45	30	117	30.8	35	45	31	119	
													10625	6.5	1	15.6	29.8	30	45	30	117	30.8	35	45	31	119	
													11125	10.5	1	25.3	41.1	45	45	38	117	42.4	45	45	39	119	
	460-3-60	7.1	52	11				1.3	4	0.5			None	-	-	-	14.2	15	20	14	57	14.7	15	20	15	58	
													11146	6	1	7.2	14.2	15	20	13	57	14.7	15	20	13	58	
													11146	11.5	1	13.8	22.3	25	25	20	57	22.9	25	25	21	58	
	575-3-60	5.1	39.5	8				1.1	7.6	0.4			None	-	-	-	10.5	15	15	11	43	10.9	15	15	11	44	
													11458	13.8	1	13.3	20.4	25	25	19	43	20.9	25	25	19	44	
													12358	23	1	22.1	31.4	35	35	29	43	31.9	35	35	29	44	
	07 (6)	208-3-60	19	123	30			2.3	5.2	1.1			None	-	-	-	33.6	35	50	33	165	35.8	40	50	36	175	
													10725	4.9	1	13.6	33.6	35	50	33	165	35.8	40	50	36	175	
													11725	12	1	33.3	48.1	50	50	44	165	50.9	60	60	47	175	
													12525	18.6	1	51.6	71	80	80	65	165	73.8	80	80	68	175	
		230-3-60	19	123	30				2.3	5.2	1			None	-	-	-	33.6	35	50	33	168	35.6	40	50	35	163
														10725	6.5	1	15.6	33.6	35	50	33	168	35.6	40	50	35	163
11725														16	1	38.5	54.6	60	60	50	168	57.1	60	60	53	163	
12525														24.8	1	59.7	81.1	90	90	75	168	83.6	90	90	77	163	
460-3-60		9.7	62	15				1.3	2.6	0.5			None	-	-	-	17.3	20	25	17	86	18.3	20	25	18	83	
													10746	6	1	7.2	17.3	20	25	11	86	18.3	20	25	12	83	
													11746	16.5	1	19.8	28	30	30	26	86	29.3	30	30	27	83	
													12646	25.5	1	30.7	41.6	45	45	38	86	42.9	45	45	39	83	
575-3-60		7.4	50	12				1.1	2	0.4			None	-	-	-	13.5	15	20	13	69	14.3	15	20	14	67	
													11758	17	1	16.4	23	25	25	21	69	24	25	25	22	67	
													12658	25.7	1	24.7	33.4	35	35	31	69	34.4	35	35	32	67	
A7 (6)		208-3-60	17.6	136	27			2.3	5.2	1.1			None	-	-	-	31.8	35	45	32	168	34	35	50	34	173	
													10725	4.9	1	13.6	31.8	35	45	32	168	34	35	50	34	173	
													11725	12	1	33.3	48.1	50	50	44	168	50.9	60	60	47	173	
													12525	18.6	1	51.6	71	80	80	65	168	73.8	80	80	68	173	
		230-3-60	17.6	136	27				2.3	5.2	1			None	-	-	-	31.8	35	45	32	171	33.8	35	50	34	176
														10725	6.5	1	15.6	31.8	35	45	32	171	33.8	35	50	34	176
														11725	16	1	38.5	54.6	60	60	50	171	57.1	60	60	53	176
														12525	24.8	1	59.7	81.1	90	90	75	171	83.6	90	90	77	176
		460-3-60	8.5	66.1	13				1.3	2.6	0.5			None	-	-	-	15.8	20	20	16	84	16.8	20	20	17	87
	10746													6	1	7.2	15.8	20	20	11	84	16.8	20	20	12	87	
	11746													16.5	1	19.8	28	30	30	26	84	29.3	30	30	27	87	
	12646													25.5	1	30.7	41.6	45	45	38	84	42.9	45	45	39	87	
	575-3-60	6.3	55.3	10				1.1	2	0.4			None	-	-	-	12.1	15	15	12	70	12.9	15	15	13	72	
													11758	17	1	16.4	23	25	25	21	70	24	25	25	22	72	
													12658	25.7	1	24.7	33.4	35	35	31	70	34.4	35	35	32	72	

ZYE04-12 Standard Static Indoor Blower - Without Powered Convenience Outlet (Continued)

Size (Tons)	Nominal Unit Voltage	Compressor 1			Compressor 2			OD Fan Motors (each)	Supply Blower Motor	Pwr Exh Motor	Pwr Conv Outlet	Electric Heat Field Installed Kit 2EK045*				MCA <sup>1</sup> (Amps)	Min Fuse <sup>2</sup> /Breaker <sup>3</sup> Size (Amps)	Max Fuse <sup>2</sup> /Breaker <sup>3</sup> Size (Amps)	Min Disconnect Rating <sup>4</sup>		MCA <sup>1</sup> w/Pwr Exh (Amps)	Min Fuse <sup>2</sup> /Breaker <sup>3</sup> Size w/ Pwr Exh (Amps)	Max Fuse <sup>2</sup> /Breaker <sup>3</sup> Size w/ Pwr Exh (Amps)	Min Disconnect Rating <sup>4</sup> w/ Pwr Exh		
		RLA	LRA	MCC	RLA	LRA	MCC					Model	kW	Stages	Amps				FLA	LRA				FLA	LRA	
08 (7.5)	208-3-60	13.6	83.1	21	13.6	83.1	21	2.3	5.2	1.1		None	-	-	-	40.4	45	50	43	208	42.6	45	50	45	218	
												11725	12	1	33.3	48.1	50	50	44	208	50.9	60	60	47	218	
												12525	18.6	1	51.6	71	80	80	65	208	73.8	80	80	68	218	
												13225	24	1	66.6	89.8	90	90	83	208	92.5	100	100	85	218	
												14225	31.8	2	88.3	116.9	125	125	108	208	119.6	125	125	110	218	
	230-3-60	13.6	83.1	21	13.6	83.1	21	2.3	5.2	1			None	-	-	-	40.4	45	50	43	211	42.4	45	50	45	206
													11725	16	1	38.5	54.6	60	60	50	211	57.1	60	60	53	206
													12525	24.8	1	59.7	81.1	90	90	75	211	83.6	90	90	77	206
													13225	32	1	77	102.8	110	110	95	211	105.3	110	110	97	206
													14225	42.4	2	102	134	150	150	123	211	136.5	150	150	126	206
	460-3-60	6.1	41	10	6.1	41	10	1.3	2.6	0.5			None	-	-	-	18.9	20	25	20	106	19.9	20	25	21	103
													11746	16.5	1	19.8	28	30	30	26	106	29.3	30	30	27	103
													12846	27.8	1	33.4	45	45	45	41	106	46.3	50	50	43	103
													13346	33	1	39.7	52.9	60	60	49	106	54.1	60	60	50	103
													14246	41.7	2	50.2	66	70	70	61	106	67.3	70	70	62	103
	575-3-60	4.2	33	7	4.2	33	7	1.1	2	0.4			None	-	-	-	13.7	15	15	14	85	14.5	15	15	15	83
11758													17	1	16.4	23	25	25	21	85	24	25	25	22	83	
13458													34	1	32.7	43.4	45	45	40	85	44.4	45	45	41	83	
09 (8.5)	208-3-60	13.7	83.1	21	13.7	83.1	21	2.3	5.2	1.1		None	-	-	-	40.6	45	50	43	208	42.8	45	50	45	218	
												11725	12	1	33.3	48.1	50	50	44	208	50.9	60	60	47	218	
												12525	18.6	1	51.6	71	80	80	65	208	73.8	80	80	68	218	
												13225	24	1	66.6	89.8	90	90	83	208	92.5	100	100	85	218	
												14225	31.8	2	88.3	116.9	125	125	108	208	119.6	125	125	110	218	
	230-3-60	13.7	83.1	21	13.7	83.1	21	2.3	5.2	1			None	-	-	-	40.6	45	50	43	211	42.6	45	50	45	206
													11725	16	1	38.5	54.6	60	60	50	211	57.1	60	60	53	206
													12525	24.8	1	59.7	81.1	90	90	75	211	83.6	90	90	77	206
													13225	32	1	77	102.8	110	110	95	211	105.3	110	110	97	206
													14225	42.4	2	102	134	150	150	123	211	136.5	150	150	126	206
	460-3-60	6.2	41	10	6.2	41	10	1.3	2.6	0.5			None	-	-	-	19.2	20	25	20	106	20.2	25	25	21	103
													11746	16.5	1	19.8	28	30	30	26	106	29.3	30	30	27	103
													12846	27.8	1	33.4	45	45	45	41	106	46.3	50	50	43	103
													13346	33	1	39.7	52.9	60	60	49	106	54.1	60	60	50	103
													14246	41.7	2	50.2	66	70	70	61	106	67.3	70	70	62	103
	575-3-60	4.8	33	8	4.8	33	8	1.1	2	0.4			None	-	-	-	15	20	20	16	85	15.8	20	20	17	83
11758													17	1	16.4	23	25	25	21	85	24	25	25	22	83	
13458													34	1	32.7	43.4	45	45	40	85	44.4	45	45	41	83	
12 (10)	208-3-60	16	110	25	16	110	25	5.8	5.2	1.1		None	-	-	-	47	50	60	49	264	49.2	50	60	52	274	
												11725	12	1	33.3	48.1	50	60	49	264	50.9	60	60	52	274	
												12525	18.6	1	51.6	71	80	80	65	264	73.8	80	80	68	274	
												13225	24	1	66.6	89.8	90	90	83	264	92.5	100	100	85	274	
												14225	31.8	2	88.3	116.9	125	125	108	264	119.6	125	125	110	274	
	230-3-60	16	110	25	16	110	25	5.2	5.2	1			None	-	-	-	46.4	50	60	49	264	48.4	50	60	51	269
													11725	16	1	38.5	54.6	60	60	50	264	57.1	60	60	53	269
													12525	24.8	1	59.7	81.1	90	90	75	264	83.6	90	90	77	269
													13225	32	1	77	102.8	110	110	95	264	105.3	110	110	97	269
													14225	42.4	2	102	134	150	150	123	264	136.5	150	150	126	269
	460-3-60	7.8	52	12	7.8	52	12	2.9	2.6	0.5			None	-	-	-	23.1	25	30	24	128	24.1	25	30	25	130
													11746	16.5	1	19.8	28	30	30	26	128	29.3	30	30	27	130
													12846	27.8	1	33.4	45	45	45	41	128	46.3	50	50	43	130
													13346	33	1	39.7	52.9	60	60	49	128	54.1	60	60	50	130
													14246	41.7	2	50.2	66	70	70	61	128	67.3	70	70	62	130
	575-3-60	5.7	38.9	9	5.7	38.9	9	2.2	2	0.4			None	-	-	-	17	20	20	18	99	17.8	20	20	19	101
11758													17	1	16.4	23	25	25	21	99	24	25	25	22	101	
13458													34	1	32.7	43.4	45	45	40	99	44.4	45	45	41	101	

ZYE04-12 Standard Static Indoor Blower - Without Powered Convenience Outlet (Continued)

Size (Tons)	Nominal Unit Voltage	Compressor 1			Compressor 2			OD Fan Motors (each)	Supply Blower Motor	Pwr Exh Motor	Pwr Conv Outlet	Electric Heat Field Installed Kit 2EK045*				MCA <sup>1</sup> (Amps)	Min Fuse <sup>2</sup> /Breaker <sup>3</sup> Size (Amps)	Max Fuse <sup>2</sup> /Breaker <sup>3</sup> Size (Amps)	Min Disconnect Rating <sup>4</sup>		MCA <sup>1</sup> w/Pwr Exh (Amps)	Min Fuse <sup>2</sup> /Breaker <sup>3</sup> Size w/ Pwr Exh (Amps)	Max Fuse <sup>2</sup> /Breaker <sup>3</sup> Size w/ Pwr Exh (Amps)	Min Disconnect Rating <sup>4</sup> /Pwr Exh		
		RLA	LRA	MCC	RLA	LRA	MCC					Model	kW	Stages	Amps				FLA	LRA				FLA	LRA	
<b>With VFD</b>																										
A7 (6)	208-3-60	17.6	136	27				2.3	7	1.1		None	-	-	-	33.6	35	50	34	206	35.8	40	50	36	211	
												10725	4.9	1	13.6	33.6	35	50	34	206	35.8	40	50	36	211	
												11725	12	1	33.3	50.4	60	60	46	206	53.1	60	60	49	211	
												12525	18.6	1	51.6	73.3	80	80	67	206	76	80	80	70	211	
	230-3-60	17.6	136	27				2.3	7.2	1			None	-	-	-	33.8	35	50	34	208	35.8	40	50	36	212
													10725	6.5	1	15.6	33.8	35	50	34	208	35.8	40	50	36	212
													11725	16	1	38.5	57.1	60	60	53	208	59.6	60	60	55	212
													12525	24.8	1	59.7	83.6	90	90	77	208	86.1	90	90	79	212
	460-3-60	8.5	66.1	13				1.3	3.6	0.5			None	-	-	-	16.8	20	25	17	103	17.8	20	25	18	105
													10746	6	1	7.2	16.8	20	25	12	103	17.8	20	25	14	105
													11746	16.5	1	19.8	29.3	30	30	27	103	30.5	35	35	28	105
													12646	25.5	1	30.7	42.9	45	45	39	103	44.1	45	45	41	105
575-3-60	6.3	55.3	10				1.1	2.5	0.4			None	-	-	-	12.6	15	15	13	78	13.4	15	15	14	80	
												11758	17	1	16.4	23.6	25	25	22	78	24.6	25	25	23	80	
												12658	25.7	1	24.7	34	35	35	31	78	35	35	35	32	80	
08 (7.5)	208-3-60	13.6	83.1	21	13.6	83.1	21	2.3	7	1.1		None	-	-	-	42.2	45	50	45	246	44.4	45	50	47	256	
												11725	12	1	33.3	50.4	60	60	46	246	53.1	60	60	49	256	
												12525	18.6	1	51.6	73.3	80	80	67	246	76	80	80	70	256	
												13225	24	1	66.6	92	100	100	85	246	94.8	100	100	87	256	
	230-3-60	13.6	83.1	21	13.6	83.1	21	2.3	7.2	1			None	-	-	-	42.4	45	50	45	248	44.4	45	50	47	243
													11725	16	1	38.5	57.1	60	60	53	248	59.6	60	60	55	243
													12525	24.8	1	59.7	83.6	90	90	77	248	86.1	90	90	79	243
													13225	32	1	77	105.3	110	110	97	248	107.8	110	110	99	243
	460-3-60	6.1	41	10	6.1	41	10	1.3	3.6	0.5			None	-	-	-	19.9	20	25	21	125	20.9	25	25	22	121
													11746	16.5	1	19.8	29.3	30	30	27	125	30.5	35	35	28	121
													12846	27.8	1	33.4	46.3	50	50	43	125	47.5	50	50	44	121
													13346	33	1	39.7	54.1	60	60	50	125	55.4	60	60	51	121
575-3-60	4.2	33	7	4.2	33	7	1.1	2.5	0.4			None	-	-	-	14.2	15	15	15	93	15	15	15	16	90	
												11758	17	1	16.4	23.6	25	25	22	93	24.6	25	25	23	90	
												13458	34	1	32.7	44	45	45	40	93	45	45	45	41	90	
09 (8.5)	208-3-60	13.7	83.1	21	13.7	83.1	21	2.3	7	1.1		None	-	-	-	42.4	45	50	45	246	44.6	45	50	47	256	
												11725	12	1	33.3	50.4	60	60	46	246	53.1	60	60	49	256	
												12525	18.6	1	51.6	73.3	80	80	67	246	76	80	80	70	256	
												13225	24	1	66.6	92	100	100	85	246	94.8	100	100	87	256	
	230-3-60	13.7	83.1	21	13.7	83.1	21	2.3	7.2	1			None	-	-	-	42.6	45	50	45	248	44.6	45	50	47	243
													11725	16	1	38.5	57.1	60	60	53	248	59.6	60	60	55	243
													12525	24.8	1	59.7	83.6	90	90	77	248	86.1	90	90	79	243
													13225	32	1	77	105.3	110	110	97	248	107.8	110	110	99	243
	460-3-60	6.2	41	10	6.2	41	10	1.3	3.6	0.5			None	-	-	-	20.2	25	25	21	125	21.2	25	25	23	121
													11746	16.5	1	19.8	29.3	30	30	27	125	30.5	35	35	28	121
													12846	27.8	1	33.4	46.3	50	50	43	125	47.5	50	50	44	121
													13346	33	1	39.7	54.1	60	60	50	125	55.4	60	60	51	121
575-3-60	4.8	33	8	4.8	33	8	1.1	2.5	0.4			None	-	-	-	15.5	20	20	16	93	16.3	20	20	17	90	
												11758	17	1	16.4	23.6	25	25	22	93	24.6	25	25	23	90	
												13458	34	1	32.7	44	45	45	40	93	45	45	45	41	90	



## ZYE04-12 Standard Static Indoor Blower - Without Powered Convenience Outlet (Continued)

Size (Tons)	Nominal Unit Voltage	Compressor 1			Compressor 2			OD Fan Motors (each)	Supply Blower Motor	Pwr Exh Motor	Pwr Conv Outlet	Electric Heat Field Installed Kit 2EK045*			MCA <sup>1</sup> (Amps)	Min Fuse <sup>2</sup> / Breaker <sup>3</sup> Size (Amps)	Max Fuse <sup>2</sup> / Breaker <sup>3</sup> Size (Amps)	Min Discon- nect Rating <sup>4</sup>		MCA <sup>1</sup> w/Pwr Exh (Amps)	Min Fuse <sup>2</sup> / Breaker <sup>3</sup> Size w/ Pwr Exh (Amps)	Max Fuse <sup>2</sup> / Breaker <sup>3</sup> Size w/ Pwr Exh (Amps)	Min Discon- nect Rating <sup>4</sup> / Pwr Exh			
		RLA	LRA	MCC	RLA	LRA	MCC					Model	kW	Stages				Amps	FLA				LRA	FLA	LRA	
		12 (10)	208-3-60	16	110	25	16					110	25	5.8				7	1.1					None	-	-
11725	12							1	33.3	50.4	60				60	52	302			53.1	60	60		54	312	
12525	18.6							1	51.6	73.3	80				80	67	302			76	80	80		70	312	
13225	24							1	66.6	92	100				100	85	302			94.8	100	100		87	312	
14225	31.8							2	88.3	119.1	125				125	110	302			121.9	125	125		112	312	
230-3-60	16		110	25	16	110	25	5.2	7.2	1			None	-	-	-	48.4	50	60	51	301	50.4	60	60	53	305
													11725	16	1	38.5	57.1	60	60	53	301	59.6	60	60	55	305
													12525	24.8	1	59.7	83.6	90	90	77	301	86.1	90	90	79	305
													13225	32	1	77	105.3	110	110	97	301	107.8	110	110	99	305
													14225	42.4	2	102	136.5	150	150	126	301	139	150	150	128	305
460-3-60	7.8		52	12	7.8	52	12	2.9	3.6	0.5			None	-	-	-	24.1	25	30	25	146	25.1	30	30	27	148
													11746	16.5	1	19.8	29.3	30	30	27	146	30.5	35	35	28	148
													12846	27.8	1	33.4	46.3	50	50	43	146	47.5	50	50	44	148
													13346	33	1	39.7	54.1	60	60	50	146	55.4	60	60	51	148
													14246	41.7	2	50.2	67.3	70	70	62	146	68.5	70	70	63	148
575-3-60	5.7		38.9	9	5.7	38.9	9	2.2	2.5	0.4			None	-	-	-	17.5	20	20	19	107	18.3	20	20	19	109
													11758	17	1	16.4	23.6	25	25	22	107	24.6	25	25	23	109
													13458	34	1	32.7	44	45	45	40	107	45	45	45	41	109

1. Minimum Circuit Ampacity.
2. Dual Element, Time Delay Type.
3. HACR type per NEC.
4. Non-fused Disconnect, Verify on the unit nameplate that the disconnect is properly sized for the application. Units with field installed electric heat kits may exceed the factory installed disconnect amperage rating.

ZYE04-12 Standard Static Indoor Blower - With Powered Convenience Outlet

Size (Tons)	Nominal Unit Voltage	Compressor 1			Compressor 2			OD Fan Motors (each)	Supply Blower Motor	Pwr Exh Motor	Pwr Conv Outlet	Electric Heat Field Installed Kit 2EK045*				MCA <sup>1</sup> (Amps)	Min Fuse <sup>2</sup> / Breaker <sup>3</sup> Size (Amps)	Max Fuse <sup>2</sup> / Breaker <sup>3</sup> Size (Amps)	Min Discon- nect Rating <sup>4</sup>		MCA <sup>1</sup> w/Pwr Exh (Amps)	Min Fuse <sup>2</sup> / Breaker <sup>3</sup> Size w/ Pwr Exh (Amps)	Max Fuse <sup>2</sup> / Breaker <sup>3</sup> Size w/ Pwr Exh (Amps)	Min Discon- nect Rating <sup>4</sup> / Pwr Exh		
		RLA	LRA	MCC	RLA	LRA	MCC					Model	kW	Stages	Amps				FLA	LRA				FLA	LRA	
04 (3)	208-1-60	16.7	79	26				1.4	6.6	1.5	8.6	None	-	-	-	33.2	35	45	33	89	34.7	35	50	35	92	
												10625	4.9	1	23.6	43.1	45	45	40	89	45	45	50	41	92	
												11125	7.9	1	38	61.1	70	70	56	89	63	70	70	58	92	
	230-1-60	16.7	79	26				1.4	6	1.3	8.6	None	-	-	-	32.6	35	45	33	89	33.9	35	50	34	92	
												10625	6.5	1	27.1	46.8	50	50	43	89	48.4	50	50	45	92	
												11125	10.5	1	43.8	67.6	70	70	62	89	69.3	70	70	64	92	
	208-3-60	10.4	73	16				1.4	6.6	1.1	8.6	None	-	-	-	25.3	30	35	26	83	26.4	30	35	27	85	
												10625	4.9	1	13.6	30.6	35	35	28	83	32	35	35	29	85	
												11125	7.9	1	21.9	41	45	45	38	83	42.4	45	45	39	85	
	230-3-60	10.4	73	16				1.4	6	1	8.6	None	-	-	-	24.7	25	35	25	83	25.7	30	35	27	85	
												10625	6.5	1	15.6	32.4	35	35	30	83	33.6	35	35	31	85	
												11125	10.5	1	25.3	44.5	45	45	41	83	45.8	50	50	42	85	
	460-3-60	5.8	38	9				0.8	3.2	0.5	8.6	None	-	-	-	13.5	15	15	14	44	14	15	15	14	45	
												10646	6	1	7.2	15.7	20	20	14	44	16.3	20	20	15	45	
												11146	11.5	1	13.8	23.9	25	25	22	44	24.6	25	25	23	45	
	575-3-60	3.8	36.5	6				0.6	6	0.4	8.6	None	-	-	-	9.5	15	15	10	41	9.9	15	15	10	41	
												11058	9.2	1	8.9	16.3	20	20	15	41	16.8	20	20	15	41	
												11458	13.8	1	13.3	21.8	25	25	20	41	22.3	25	25	20	41	
	05 (4)	208-1-60	21.8	117	34				1.4	8.4	1.5	8.6	None	-	-	-	41.4	45	60	41	127	42.9	45	60	43	130
													10625	4.9	1	23.6	45.4	50	60	42	127	47.3	50	60	43	130
													11125	7.9	1	38	63.4	70	70	58	127	65.3	70	70	60	130
		230-1-60	21.8	117	34				1.4	7.6	1.3	8.6	None	-	-	-	40.6	45	60	40	127	41.9	45	60	42	130
													10625	6.5	1	27.1	48.8	50	60	45	127	50.4	60	60	46	130
													11125	10.5	1	43.8	69.6	70	70	64	127	71.3	80	80	66	130
208-3-60		13.7	83.1	21				1.4	8.4	1.1	8.6	None	-	-	-	31.2	35	40	32	93	32.3	35	45	33	95	
												10625	4.9	1	13.6	32.9	35	40	32	93	34.3	35	45	33	95	
												11125	7.9	1	21.9	43.3	45	45	40	93	44.6	45	45	41	95	
230-3-60		13.7	83.1	21				1.4	7.6	1	8.6	None	-	-	-	30.4	35	40	31	93	31.4	35	45	32	95	
												10625	6.5	1	15.6	34.4	35	40	32	93	35.6	40	45	33	95	
												11125	10.5	1	25.3	46.5	50	50	43	93	47.8	50	50	44	95	
460-3-60		6.2	41	10				0.8	4	0.5	8.6	None	-	-	-	14.8	15	20	15	47	15.3	20	20	16	48	
												10646	6	1	7.2	16.7	20	20	15	47	17.3	20	20	16	48	
												11146	11.5	1	13.8	24.9	25	25	23	47	25.6	30	30	24	48	
575-3-60		4.8	33	8				0.6	7.6	0.4	8.6	None	-	-	-	11.4	15	15	12	37	11.8	15	15	12	38	
												11058	9.2	1	8.9	17.1	20	20	16	37	17.6	20	20	16	38	
												11458	13.8	1	13.3	22.6	25	25	21	37	23.1	25	25	21	38	

ZYE04-12 Standard Static Indoor Blower - With Powered Convenience Outlet (Continued)

Size (Tons)	Nominal Unit Voltage	Compressor 1			Compressor 2			OD Fan Motors (each)	Supply Blower Motor	Pwr Exh Motor	Pwr Conv Outlet	Electric Heat Field Installed Kit 2EK045*			MCA <sup>1</sup> (Amps)	Min Fuse <sup>2</sup> / Breaker <sup>3</sup> Size (Amps)	Max Fuse <sup>2</sup> / Breaker <sup>3</sup> Size (Amps)	Min Disconnect Rating <sup>4</sup>		MCA <sup>1</sup> w/Pwr Exh (Amps)	Min Fuse <sup>2</sup> / Breaker <sup>3</sup> Size w/ Pwr Exh (Amps)	Max Fuse <sup>2</sup> / Breaker <sup>3</sup> Size w/ Pwr Exh (Amps)	Min Disconnect Rating <sup>4</sup> / Pwr Exh			
		RLA	LRA	MCC	RLA	LRA	MCC					Model	kW	Stages				Amps	FLA				LRA	FLA	LRA	
06 (5)	208-1-60	25	134	39				2.3	8.4	1.5	8.6	None	-	-	-	46.3	50	70	46	145	47.8	50	70	48	149	
												10625	4.9	1	23.6	46.3	50	70	46	145	47.8	50	70	48	149	
												11125	7.9	1	38	63.4	70	70	58	145	65.3	70	70	60	149	
	230-1-60	25	134	39				2.3	7.6	1.3	8.6	None	-	-	-	45.5	50	70	45	145	46.8	50	70	47	148	
												10625	6.5	1	27.1	48.8	50	70	45	145	50.4	60	70	47	148	
												11125	10.5	1	43.8	69.6	70	70	64	145	71.3	80	80	66	148	
	208-3-60	15.9	110	25				2.3	8.4	1.1	8.6	None	-	-	-	34.9	35	50	36	121	36	40	50	37	124	
												10625	4.9	1	13.6	34.9	35	50	36	121	36	40	50	37	124	
												11125	7.9	1	21.9	43.3	45	50	40	121	44.6	45	50	41	124	
	230-3-60	15.9	110	25				2.3	7.6	1	8.6	None	-	-	-	34.1	35	45	35	121	35.1	40	50	36	124	
												10625	6.5	1	15.6	34.4	35	45	35	121	35.6	40	50	36	124	
												11125	10.5	1	25.3	46.5	50	50	43	121	47.8	50	50	44	124	
	460-3-60	7.1	52	11				1.3	4	0.5	8.6	None	-	-	-	16.4	20	20	17	59	16.9	20	20	17	60	
												11146	6	1	7.2	16.7	20	20	15	59	17.3	20	20	16	60	
												11146	11.5	1	13.8	24.9	25	25	23	59	25.6	30	30	24	60	
	575-3-60	5.1	39.5	8				1.1	7.6	0.4	8.6	None	-	-	-	12.3	15	15	13	44	12.7	15	15	13	45	
												11458	13.8	1	13.3	22.6	25	25	21	44	23.1	25	25	21	45	
												12358	23	1	22.1	33.6	35	35	31	44	34.1	35	35	31	45	
	07 (6)	208-3-60	19	123	30			2.3	5.2	1.1	8.6	None	-	-	-	37.9	40	50	38	169	40.1	45	50	41	179	
												10725	4.9	1	13.6	37.9	40	50	38	169	40.1	45	50	41	179	
												11725	12	1	33.3	53.5	60	60	49	169	56.3	60	60	52	179	
												12525	18.6	1	51.6	76.4	80	80	70	169	79.1	80	80	73	179	
		230-3-60	19	123	30				2.3	5.2	1	8.6	None	-	-	-	37.9	40	50	38	172	39.9	40	50	40	167
													10725	6.5	1	15.6	37.9	40	50	38	172	39.9	40	50	40	167
11725													16	1	38.5	60	60	60	55	172	62.5	70	70	58	167	
12525													24.8	1	59.7	86.5	90	90	80	172	89	90	90	82	167	
460-3-60		9.7	62	15				1.3	2.6	0.5	8.6	None	-	-	-	19.5	20	25	20	88	20.5	25	25	21	85	
												10746	6	1	7.2	19.5	20	25	14	88	20.5	25	25	15	85	
												11746	16.5	1	19.8	30.7	35	35	28	88	31.9	35	35	29	85	
												12646	25.5	1	30.7	44.3	45	45	41	88	45.6	50	50	42	85	
575-3-60		7.4	50	12				1.1	2	0.4	8.6	None	-	-	-	15.2	20	20	15	71	16	20	20	16	68	
												11758	17	1	16.4	25.2	30	30	23	71	26.2	30	30	24	68	
												12658	25.7	1	24.7	35.5	40	40	33	71	36.5	40	40	34	68	
A7 (6)		208-3-60	17.6	136	27			2.3	5.2	1.1	8.6	None	-	-	-	36.1	40	50	36	172	38.3	40	50	39	177	
												10725	4.9	1	13.6	36.1	40	50	36	172	38.3	40	50	39	177	
												11725	12	1	33.3	53.5	60	60	49	172	56.3	60	60	52	177	
												12525	18.6	1	51.6	76.4	80	80	70	172	79.1	80	80	73	177	
		230-3-60	17.6	136	27				2.3	5.2	1	8.6	None	-	-	-	36.1	40	50	36	175	38.1	40	50	39	180
													10725	6.5	1	15.6	36.1	40	50	36	175	38.1	40	50	39	180
													11725	16	1	38.5	60	60	60	55	175	62.5	70	70	58	180
													12525	24.8	1	59.7	86.5	90	90	80	175	89	90	90	82	180
		460-3-60	8.5	66.1	13				1.3	2.6	0.5	8.6	None	-	-	-	18	20	25	18	87	19	20	25	19	89
	10746												6	1	7.2	18	20	25	14	87	19	20	25	15	89	
	11746												16.5	1	19.8	30.7	35	35	28	87	31.9	35	35	29	89	
	12646												25.5	1	30.7	44.3	45	45	41	87	45.6	50	50	42	89	
	575-3-60	6.3	55.3	10				1.1	2	0.4	8.6	None	-	-	-	13.8	15	20	14	72	14.6	15	20	15	74	
												11758	17	1	16.4	25.2	30	30	23	72	26.2	30	30	24	74	
												12658	25.7	1	24.7	35.5	40	40	33	72	36.5	40	40	34	74	

**ZYE04-12 Standard Static Indoor Blower - With Powered Convenience Outlet (Continued)**

Size (Tons)	Nominal Unit Voltage	Compressor 1			Compressor 2			OD Fan Motors (each)	Supply Blower Motor	Pwr Exh Motor	Pwr Conv Outlet	Electric Heat Field Installed Kit 2EK045*			MCA <sup>1</sup> (Amps)	Min Fuse <sup>2</sup> / Breaker <sup>3</sup> Size (Amps)	Max Fuse <sup>2</sup> / Breaker <sup>3</sup> Size (Amps)	Min Disconnect Rating <sup>4</sup>		MCA <sup>1</sup> w/Pwr Exh (Amps)	Min Fuse <sup>2</sup> / Breaker <sup>3</sup> Size w/ Pwr Exh (Amps)	Max Fuse <sup>2</sup> / Breaker <sup>3</sup> Size w/ Pwr Exh (Amps)	Min Disconnect Rating <sup>4</sup> / Pwr Exh		
		RLA	LRA	MCC	RLA	LRA	MCC					Model	kW	Stages				Amps	FLA				LRA	FLA	LRA
08 (7.5)	208-3-60	13.6	83.1	21	13.6	83.1	21	2.3	5.2	1.1	8.6	None	-	-	-	44.7	45	50	47	212	46.9	50	50	50	222
												11725	12	1	33.3	53.5	60	60	49	212	56.3	60	60	52	222
												12525	18.6	1	51.6	76.4	80	80	70	212	79.1	80	80	73	222
												13225	24	1	66.6	95.1	100	100	88	212	97.9	100	100	90	222
												14225	31.8	2	88.3	122.3	125	125	112	212	125	150	150	115	222
	230-3-60	13.6	83.1	21	13.6	83.1	21	2.3	5.2	1	8.6	None	-	-	-	44.7	45	50	47	216	46.7	50	60	50	210
												11725	16	1	38.5	60	60	55	216	62.5	70	70	58	210	
												12525	24.8	1	59.7	86.5	90	90	80	216	89	90	90	82	210
												13225	32	1	77	108.1	110	110	99	216	110.6	125	125	102	210
												14225	42.4	2	102	139.4	150	150	128	216	141.9	150	150	131	210
	460-3-60	6.1	41	10	6.1	41	10	1.3	2.6	0.5	8.6	None	-	-	-	21.1	25	25	23	108	22.1	25	25	24	105
												11746	16.5	1	19.8	30.7	35	35	28	108	31.9	35	35	29	105
12846												27.8	1	33.4	47.7	50	50	44	108	48.9	50	50	45	105	
13346												33	1	39.7	55.6	60	60	51	108	56.8	60	60	52	105	
14246												41.7	2	50.2	68.7	70	70	63	108	69.9	70	70	64	105	
575-3-60	4.2	33	7	4.2	33	7	1.1	2	0.4	8.6	None	-	-	-	15.4	20	20	16	87	16.2	20	20	17	84	
											11758	17	1	16.4	25.2	30	30	23	87	26.2	30	30	24	84	
											13458	34	1	32.7	45.5	50	50	42	87	46.5	50	50	43	84	
09 (8.5)	208-3-60	13.7	83.1	21	13.7	83.1	21	2.3	5.2	1.1	8.6	None	-	-	-	44.9	45	50	48	212	47.1	50	50	50	222
												11725	12	1	33.3	53.5	60	60	49	212	56.3	60	60	52	222
												12525	18.6	1	51.6	76.4	80	80	70	212	79.1	80	80	73	222
												13225	24	1	66.6	95.1	100	100	88	212	97.9	100	100	90	222
												14225	31.8	2	88.3	122.3	125	125	112	212	125	150	150	115	222
	230-3-60	13.7	83.1	21	13.7	83.1	21	2.3	5.2	1	8.6	None	-	-	-	44.9	45	50	48	216	46.9	50	60	50	210
												11725	16	1	38.5	60	60	55	216	62.5	70	70	58	210	
												12525	24.8	1	59.7	86.5	90	90	80	216	89	90	90	82	210
												13225	32	1	77	108.1	110	110	99	216	110.6	125	125	102	210
												14225	42.4	2	102	139.4	150	150	128	216	141.9	150	150	131	210
	460-3-60	6.2	41	10	6.2	41	10	1.3	2.6	0.5	8.6	None	-	-	-	21.4	25	25	23	108	22.4	25	25	24	105
												11746	16.5	1	19.8	30.7	35	35	28	108	31.9	35	35	29	105
12846												27.8	1	33.4	47.7	50	50	44	108	48.9	50	50	45	105	
13346												33	1	39.7	55.6	60	60	51	108	56.8	60	60	52	105	
14246												41.7	2	50.2	68.7	70	70	63	108	69.9	70	70	64	105	
575-3-60	4.8	33	8	4.8	33	8	1.1	2	0.4	8.6	None	-	-	-	16.7	20	20	18	87	17.5	20	20	19	84	
											11758	17	1	16.4	25.2	30	30	23	87	26.2	30	30	24	84	
											13458	34	1	32.7	45.5	50	50	42	87	46.5	50	50	43	84	
12 (10)	208-3-60	16	110	25	16	110	25	5.8	5.2	1.1	8.6	None	-	-	-	51.3	60	60	54	269	53.5	60	60	57	279
												11725	12	1	33.3	53.5	60	60	54	269	56.3	60	60	57	279
												12525	18.6	1	51.6	76.4	80	80	70	269	79.1	80	80	73	279
												13225	24	1	66.6	95.1	100	100	88	269	97.9	100	100	90	279
												14225	31.8	2	88.3	122.3	125	125	112	269	125	150	150	115	279
	230-3-60	16	110	25	16	110	25	5.2	5.2	1	8.6	None	-	-	-	50.7	60	60	54	268	52.7	60	60	56	273
												11725	16	1	38.5	60	60	55	268	62.5	70	70	58	273	
												12525	24.8	1	59.7	86.5	90	90	80	268	89	90	90	82	273
												13225	32	1	77	108.1	110	110	99	268	110.6	125	125	102	273
												14225	42.4	2	102	139.4	150	150	128	268	141.9	150	150	131	273
	460-3-60	7.8	52	12	7.8	52	12	2.9	2.6	0.5	8.6	None	-	-	-	25.3	30	30	27	130	26.3	30	30	28	132
												11746	16.5	1	19.8	30.7	35	35	28	130	31.9	35	35	29	132
12846												27.8	1	33.4	47.7	50	50	44	130	48.9	50	50	45	132	
13346												33	1	39.7	55.6	60	60	51	130	56.8	60	60	52	132	
14246												41.7	2	50.2	68.7	70	70	63	130	69.9	70	70	64	132	
575-3-60	5.7	38.9	9	5.7	38.9	9	2.2	2	0.4	8.6	None	-	-	-	18.7	20	20	20	101	19.5	20	20	21	103	
											11758	17	1	16.4	25.2	30	30	23	101	26.2	30	30	24	103	
											13458	34	1	32.7	45.5	50	50	42	101	46.5	50	50	43	103	

**ZYE04-12 Standard Static Indoor Blower - With Powered Convenience Outlet (Continued)**

Size (Tons)	Nominal Unit Voltage	Compressor 1			Compressor 2			OD Fan Motors (each)	Supply Blower Motor	Pwr Exh Motor	Pwr Conv Outlet	Electric Heat Field Installed Kit 2EK045*				MCA <sup>1</sup> (Amps)	Min Fuse <sup>2</sup> /Breaker <sup>3</sup> Size (Amps)	Max Fuse <sup>2</sup> /Breaker <sup>3</sup> Size (Amps)	Min Disconnect Rating <sup>4</sup>		MCA <sup>1</sup> w/Pwr Exh (Amps)	Min Fuse <sup>2</sup> /Breaker <sup>3</sup> Size w/ Pwr Exh (Amps)	Max Fuse <sup>2</sup> /Breaker <sup>3</sup> Size w/ Pwr Exh (Amps)	Min Disconnect Rating <sup>6</sup> /Pwr Exh	
		RLA	LRA	MCC	RLA	LRA	MCC					Model	kW	Stages	Amps				FLA	LRA				FLA	LRA
<b>With VFD</b>																									
A7 (6)	208-3-60	17.6	136	27				2.3	7	1.1	8.6	None	-	-	-	37.9	40	50	39	210	40.1	45	50	41	215
												10725	4.9	1	13.6	37.9	40	50	39	210	40.1	45	50	41	215
												11725	12	1	33.3	55.8	60	60	51	210	58.5	60	60	54	215
												12525	18.6	1	51.6	78.6	80	80	72	210	81.4	90	90	75	215
	230-3-60	17.6	136	27				2.3	7.2	1	8.6	None	-	-	-	38.1	40	50	39	212	40.1	45	50	41	217
												10725	6.5	1	15.6	38.1	40	50	39	212	40.1	45	50	41	217
												11725	16	1	38.5	62.5	70	70	58	212	65	70	70	60	217
												12525	24.8	1	59.7	89	90	90	82	212	91.5	100	100	84	217
	460-3-60	8.5	66.1	13				1.3	3.6	0.5	8.6	None	-	-	-	19	20	25	19	105	20	20	25	21	107
												10746	6	1	7.2	19	20	25	15	105	20	20	25	16	107
												11746	16.5	1	19.8	31.9	35	35	29	105	33.2	35	35	31	107
												12646	25.5	1	30.7	45.6	50	50	42	105	46.8	50	50	43	107
575-3-60	6.3	55.3	10				1.1	2.5	0.4	8.6	None	-	-	-	14.3	15	20	15	79	15.1	20	20	16	81	
											11758	17	1	16.4	25.8	30	30	24	79	26.8	30	30	25	81	
											12658	25.7	1	24.7	36.2	40	40	33	79	37.2	40	40	34	81	
											None	-	-	-	46.5	50	60	50	250	48.7	50	60	52	260	
08 (7.5)	208-3-60	13.6	83.1	21	13.6	83.1	21	2.3	7	1.1	8.6	11725	12	1	33.3	55.8	60	60	51	250	58.5	60	60	54	260
												12525	18.6	1	51.6	78.6	80	80	72	250	81.4	90	90	75	260
												13225	24	1	66.6	97.4	100	100	90	250	100.1	110	110	92	260
												14225	31.8	2	88.3	124.5	125	125	115	250	127.3	150	150	117	260
	230-3-60	13.6	83.1	21	13.6	83.1	21	2.3	7.2	1	8.6	None	-	-	-	46.7	50	60	50	252	48.7	50	60	52	247
												11725	16	1	38.5	62.5	70	70	58	252	65	70	70	60	247
												12525	24.8	1	59.7	89	90	90	82	252	91.5	100	100	84	247
												13225	32	1	77	110.6	125	125	102	252	113.1	125	125	104	247
	460-3-60	6.1	41	10	6.1	41	10	1.3	3.6	0.5	8.6	14225	42.4	2	102	141.9	150	150	131	252	144.4	150	150	133	247
												None	-	-	-	22.1	25	25	24	127	23.1	25	25	25	123
												11746	16.5	1	19.8	31.9	35	35	29	127	33.2	35	35	31	123
												12846	27.8	1	33.4	48.9	50	50	45	127	50.2	60	60	46	123
575-3-60	4.2	33	7	4.2	33	7	1.1	2.5	0.4	8.6	13346	33	1	39.7	56.8	60	60	52	127	58.1	60	60	53	123	
											14246	41.7	2	50.2	69.9	70	70	64	127	71.2	80	80	65	123	
											None	-	-	-	15.9	20	20	17	95	16.7	20	20	18	92	
											11758	17	1	16.4	25.8	30	30	24	95	26.8	30	30	25	92	
09 (8.5)	208-3-60	13.7	83.1	21	13.7	83.1	21	2.3	7	1.1	8.6	13458	34	1	32.7	46.2	50	50	42	95	47.2	50	50	43	92
												None	-	-	-	46.7	50	60	50	250	48.9	50	60	52	260
												11725	12	1	33.3	55.8	60	60	51	250	58.5	60	60	54	260
												12525	18.6	1	51.6	78.6	80	80	72	250	81.4	90	90	75	260
	230-3-60	13.7	83.1	21	13.7	83.1	21	2.3	7.2	1	8.6	13225	24	1	66.6	97.4	100	100	90	250	100.1	110	110	92	260
												14225	31.8	2	88.3	124.5	125	125	115	250	127.3	150	150	117	260
												None	-	-	-	46.9	50	60	50	252	48.9	50	60	52	247
												11725	16	1	38.5	62.5	70	70	58	252	65	70	70	60	247
	460-3-60	6.2	41	10	6.2	41	10	1.3	3.6	0.5	8.6	12525	24.8	1	59.7	89	90	90	82	252	91.5	100	100	84	247
												13225	32	1	77	110.6	125	125	102	252	113.1	125	125	104	247
												14225	42.4	2	102	141.9	150	150	131	252	144.4	150	150	133	247
												None	-	-	-	22.4	25	25	24	127	23.4	25	25	25	123
575-3-60	4.8	33	8	4.8	33	8	1.1	2.5	0.4	8.6	11746	16.5	1	19.8	31.9	35	35	29	127	33.2	35	35	31	123	
											12846	27.8	1	33.4	48.9	50	50	45	127	50.2	60	60	46	123	
											13346	33	1	39.7	56.8	60	60	52	127	58.1	60	60	53	123	
											14246	41.7	2	50.2	69.9	70	70	64	127	71.2	80	80	65	123	
None	-	-	-	17.2	20	20	18	95	18	20	20	19	92												
11758	17	1	16.4	25.8	30	30	24	95	26.8	30	30	25	92												
13458	34	1	32.7	46.2	50	50	42	95	47.2	50	50	43	92												

**ZYE04-12 Standard Static Indoor Blower - With Powered Convenience Outlet (Continued)**

Size (Tons)	Nominal Unit Voltage	Compressor 1			Compressor 2			OD Fan Motors (each)	Supply Blower Motor	Pwr Exh Motor	Pwr Conv Outlet	Electric Heat Field Installed Kit 2EK045*				MCA <sup>1</sup> (Amps)	Min Fuse <sup>2/</sup> Breaker <sup>3</sup> Size (Amps)	Max Fuse <sup>2/</sup> Breaker <sup>3</sup> Size (Amps)	Min Discon- nect Rating <sup>4</sup>		MCA <sup>1</sup> w/Pwr Exh (Amps)	Min Fuse <sup>2/</sup> Breaker <sup>3</sup> Size w/ Pwr Exh (Amps)	Max Fuse <sup>2/</sup> Breaker <sup>3</sup> Size w/ Pwr Exh (Amps)	Min Discon- nect Rating <sup>4</sup> / Pwr Exh	
		RLA	LRA	MCC	RLA	LRA	MCC					Model	kW	Stages	Amps				FLA	LRA				FLA	LRA
12 (10)	208-3-60	16	110	25	16	110	25	5.8	7	1.1	8.6	None	-	-	-	53.1	60	60	56	306	55.3	60	70	59	316
												11725	12	1	33.3	55.8	60	60	56	306	58.5	60	70	59	316
												12525	18.6	1	51.6	78.6	80	80	72	306	81.4	90	90	75	316
												13225	24	1	66.6	97.4	100	100	90	306	100.1	110	110	92	316
												14225	31.8	2	88.3	124.5	125	125	115	306	127.3	150	150	117	316
	230-3-60	16	110	25	16	110	25	5.2	7.2	1	8.6	None	-	-	-	52.7	60	60	56	305	54.7	60	70	58	310
												11725	16	1	38.5	62.5	70	70	58	305	65	70	70	60	310
												12525	24.8	1	59.7	89	90	90	82	305	91.5	100	100	84	310
												13225	32	1	77	110.6	125	125	102	305	113.1	125	125	104	310
												14225	42.4	2	102	141.9	150	150	131	305	144.4	150	150	133	310
	460-3-60	7.8	52	12	7.8	52	12	2.9	3.6	0.5	8.6	None	-	-	-	26.3	30	30	28	148	27.3	30	30	29	150
												11746	16.5	1	19.8	31.9	35	35	29	148	33.2	35	35	31	150
												12846	27.8	1	33.4	48.9	50	50	45	148	50.2	60	60	46	150
												13346	33	1	39.7	56.8	60	60	52	148	58.1	60	60	53	150
												14246	41.7	2	50.2	69.9	70	70	64	148	71.2	80	80	65	150
	575-3-60	5.7	38.9	9	5.7	38.9	9	2.2	2.5	0.4	8.6	None	-	-	-	19.2	20	20	20	109	20	20	20	21	110
												11758	17	1	16.4	25.8	30	30	24	109	26.8	30	30	25	110
												13458	34	1	32.7	46.2	50	50	42	109	47.2	50	50	43	110

1. Minimum Circuit Ampacity.
2. Dual Element, Time Delay Type.
3. HACR type per NEC.
4. Non-fused Disconnect, Verify on the unit nameplate that the disconnect is properly sized for the application. Units with field installed electric heat kits may exceed the factory installed disconnect amperage rating.

**ZYE04-12 Medium Static Indoor Blower - Without Powered Convenience Outlet**

Size (Tons)	Nominal Unit Voltage	Compressor 1			Compressor 2			OD Fan Motors (each)	Supply Blower Motor	Pwr Exh Motor	Pwr Conv Outlet	Electric Heat Field Installed Kit 2EK045*				MCA <sup>1</sup> (Amps)	Min Fuse <sup>2</sup> /Breaker <sup>3</sup> Size (Amps)	Max Fuse <sup>2</sup> /Breaker <sup>3</sup> Size (Amps)	Min Disconnect Rating <sup>4</sup>		MCA <sup>1</sup> w/Pwr Exh (Amps)	Min Fuse <sup>2</sup> /Breaker <sup>3</sup> Size w/ Pwr Exh (Amps)	Max Fuse <sup>2</sup> /Breaker <sup>3</sup> Size w/ Pwr Exh (Amps)	Min Disconnect Rating <sup>4</sup> /Pwr Exh			
		RLA	LRA	MCC	RLA	LRA	MCC					Model	kW	Stages	Amps				FLA	LRA				FLA	LRA		
04 (3)	208-1-60	16.7	79	26				1.4	7.6	1.5		None	-	-	-	29.9	30	45	30	115	31.4	35	45	31	119		
												10625	4.9	1	23.6	39	40	45	36	115	40.9	45	45	38	119		
												11125	7.9	1	38	57	60	60	52	115	58.9	60	60	54	119		
	230-1-60	16.7	79	26				1.4	7	1.3			None	-	-	-	29.3	30	45	29	118	30.6	35	45	30	121	
													10625	6.5	1	27.1	42.6	45	45	39	118	44.3	45	45	41	121	
													11125	10.5	1	43.8	63.5	70	70	58	118	65.1	70	70	60	121	
	208-3-60	10.4	73	16				1.4	5.2	1.1			None	-	-	-	19.6	20	30	20	99	20.7	25	30	21	101	
													10625	4.9	1	13.6	23.5	25	30	22	99	24.9	25	30	23	101	
													11125	7.9	1	21.9	33.9	35	35	31	99	35.3	40	40	32	101	
	230-3-60	10.4	73	16				1.4	5.2	1			None	-	-	-	19.6	20	30	20	101	20.6	25	30	21	104	
													10625	6.5	1	15.6	26	30	30	24	101	27.3	30	30	25	104	
													11125	10.5	1	25.3	38.1	40	40	35	101	39.4	40	40	36	104	
	460-3-60	5.8	38	9				0.8	2.6	0.5			None	-	-	-	10.7	15	15	11	52	11.2	15	15	11	54	
													10646	6	1	7.2	12.3	15	15	11	52	12.9	15	15	12	54	
													11146	11.5	1	13.8	20.5	25	25	19	52	21.1	25	25	19	54	
	575-3-60	3.8	36.5	6				0.6	2	0.4			None	-	-	-	7.4	15	15	7	48	7.8	15	15	8	49	
													11058	9.2	1	8.9	13.6	15	15	13	48	14.1	15	15	13	49	
													11458	13.8	1	13.3	19.1	20	20	18	48	19.6	20	20	18	49	
	05 (4)	208-1-60	21.8	117	34				1.4	7.6	1.5		None	-	-	-	36.3	40	50	35	153	37.8	40	50	37	157	
													10625	4.9	1	23.6	39	40	50	36	153	40.9	45	50	38	157	
													11125	7.9	1	38	57	60	60	52	153	58.9	60	60	54	157	
		230-1-60	21.8	117	34				1.4	7	1.3			None	-	-	-	35.7	40	50	35	156	37	40	50	36	159
														10625	6.5	1	27.1	42.6	45	50	39	156	44.3	45	50	41	159
														11125	10.5	1	43.8	63.5	70	70	58	156	65.1	70	70	60	159
208-3-60		13.7	83.1	21				1.4	5.2	1.1			None	-	-	-	23.7	25	35	23	109	24.8	25	35	25	111	
													10625	4.9	1	13.6	23.7	25	35	23	109	24.9	25	35	25	111	
													11125	7.9	1	21.9	33.9	35	35	31	109	35.3	40	40	32	111	
230-3-60		13.7	83.1	21				1.4	5.2	1			None	-	-	-	23.7	25	35	23	111	24.7	25	35	24	114	
													10625	6.5	1	15.6	26	30	35	24	111	27.3	30	35	25	114	
													11125	10.5	1	25.3	38.1	40	40	35	111	39.4	40	40	36	114	
460-3-60		6.2	41	10				0.8	2.6	0.5			None	-	-	-	11.2	15	15	11	55	11.7	15	15	12	57	
													10646	6	1	7.2	12.3	15	15	11	55	12.9	15	15	12	57	
													11146	11.5	1	13.8	20.5	25	25	19	55	21.1	25	25	19	57	
575-3-60		4.8	33	8				0.6	2	0.4			None	-	-	-	8.6	15	15	9	45	9	15	15	9	45	
													11058	9.2	1	8.9	13.6	15	15	13	45	14.1	15	15	13	45	
													11458	13.8	1	13.3	19.1	20	20	18	45	19.6	20	20	18	45	

ZYE04-12 Medium Static Indoor Blower - Without Powered Convenience Outlet (Continued)

Size (Tons)	Nominal Unit Voltage	Compressor 1			Compressor 2			OD Fan Motors (each)	Supply Blower Motor	Pwr Exh Motor	Pwr Conv Outlet	Electric Heat Field Installed Kit 2EK045*				MCA <sup>1</sup> (Amps)	Min Fuse <sup>2</sup> / Breaker <sup>3</sup> Size (Amps)	Max Fuse <sup>2</sup> / Breaker <sup>3</sup> Size (Amps)	Min Disconnect Rating <sup>4</sup>		MCA <sup>1</sup> w/Pwr Exh (Amps)	Min Fuse <sup>2</sup> / Breaker <sup>3</sup> Size w/ Pwr Exh (Amps)	Max Fuse <sup>2</sup> / Breaker <sup>3</sup> Size w/ Pwr Exh (Amps)	Min Disconnect Rating <sup>6</sup> / Pwr Exh		
		RLA	LRA	MCC	RLA	LRA	MCC					Model	kW	Stages	Amps				FLA	LRA				FLA	LRA	
06 (5)	208-1-60	25	134	39				2.3	6.8	1.5		None	-	-	-	40.4	45	60	39	171	41.9	45	60	41	175	
												10625	4.9	1	23.6	40.4	45	60	39	171	41.9	45	60	41	175	
												11125	7.9	1	38	56	60	60	52	171	57.9	60	60	53	175	
	230-1-60	25	134	39				2.3	6.2	1.3			None	-	-	-	39.8	40	60	39	172	41.1	45	60	40	175
													10625	6.5	1	27.1	41.6	45	60	39	172	43.3	45	60	40	175
													11125	10.5	1	43.8	62.5	70	70	58	172	64.1	70	70	59	175
	208-3-60	15.9	110	25				2.3	7	1.1			None	-	-	-	29.2	30	45	29	175	30.3	35	45	30	177
													10625	4.9	1	13.6	29.2	30	45	29	175	30.3	35	45	30	177
													11125	7.9	1	21.9	36.1	40	45	33	175	37.5	40	45	35	177
													11625	12	1	33.3	50.4	60	60	46	175	51.8	60	60	48	177
	230-3-60	15.9	110	25				2.3	7.2	1			None	-	-	-	29.4	30	45	29	177	30.4	35	45	30	179
													10625	6.5	1	15.6	29.4	30	45	29	177	30.4	35	45	30	179
													11125	10.5	1	25.3	40.6	45	45	37	177	41.9	45	45	39	179
													11625	16	1	38.5	57.1	60	60	53	177	58.4	60	60	54	179
	460-3-60	7.1	52	11				1.3	3.6	0.5			None	-	-	-	13.8	15	20	14	86	14.3	15	20	14	87
													11146	6	1	7.2	13.8	15	20	12	86	14.3	15	20	13	87
													11146	11.5	1	13.8	21.8	25	25	20	86	22.4	25	25	21	87
													11446	14	1	16.8	25.5	30	30	23	86	26.1	30	30	24	87
	575-3-60	5.1	39.5	8				1.1	2.5	0.4			None	-	-	-	10	15	15	10	60	10.4	15	15	10	60
													11458	13.8	1	13.3	19.8	20	20	18	60	20.3	25	25	19	60
													12358	23	1	22.1	30.8	35	35	28	60	31.3	35	35	29	60
	07 (6)	208-3-60	19	123	30			2.3	7.5	1.1			None	-	-	-	35.9	40	50	36	191	38.1	40	50	38	201
													10725	4.9	1	13.6	35.9	40	50	36	191	38.1	40	50	38	201
													11725	12	1	33.3	51	60	60	47	191	53.8	60	60	49	201
12525													18.6	1	51.6	73.9	80	80	68	191	76.6	80	80	70	201	
230-3-60		19	123	30			2.3	7.5	1				None	-	-	-	35.9	40	50	36	198	37.9	40	50	38	193
													10725	6.5	1	15.6	35.9	40	50	36	198	37.9	40	50	38	193
													11725	16	1	38.5	57.5	60	60	53	198	60	60	60	55	193
													12525	24.8	1	59.7	84	90	90	77	198	86.5	90	90	80	193
460-3-60		9.7	62	15			1.3	3.4	0.5				None	-	-	-	18.1	20	25	18	101	19.1	20	25	19	98
													10746	6	1	7.2	18.1	20	25	12	101	19.1	20	25	13	98
													11746	16.5	1	19.8	29	30	30	27	101	30.3	35	35	28	98
													12646	25.5	1	30.7	42.6	45	45	39	101	43.9	45	45	40	98
575-3-60		7.4	50	12			1.1	2.8	0.4				None	-	-	-	14.3	15	20	14	81	15.1	20	20	15	79
													11758	17	1	16.4	24	25	25	22	81	25	25	23	79	
													12658	25.7	1	24.7	34.4	35	35	32	81	35.4	40	40	33	79
A7 (6)	208-3-60	17.6	136	27			2.3	7.5	1.1			None	-	-	-	34.1	35	50	34	194	36.3	40	50	37	199	
												10725	4.9	1	13.6	34.1	35	50	34	194	36.3	40	50	37	199	
												11725	12	1	33.3	51	60	60	47	194	53.8	60	60	49	199	
												12525	18.6	1	51.6	73.9	80	80	68	194	76.6	80	80	70	199	
	230-3-60	17.6	136	27			2.3	7.5	1				None	-	-	-	34.1	35	50	34	201	36.1	40	50	36	206
													10725	6.5	1	15.6	34.1	35	50	34	201	36.1	40	50	36	206
													11725	16	1	38.5	57.5	60	60	53	201	60	60	60	55	206
													12525	24.8	1	59.7	84	90	90	77	201	86.5	90	90	80	206
	460-3-60	8.5	66.1	13			1.3	3.4	0.5				None	-	-	-	16.6	20	25	17	99	17.6	20	25	18	102
													10746	6	1	7.2	16.6	20	25	12	99	17.6	20	25	13	102
													11746	16.5	1	19.8	29	30	30	27	99	30.3	35	35	28	102
													12646	25.5	1	30.7	42.6	45	45	39	99	43.9	45	45	40	102
	575-3-60	6.3	55.3	10			1.1	2.8	0.4				None	-	-	-	12.9	15	15	13	82	13.7	15	15	14	84
													11758	17	1	16.4	24	25	25	22	82	25	25	23	84	
													12658	25.7	1	24.7	34.4	35	35	32	82	35.4	40	40	33	84



ZYE04-12 Medium Static Indoor Blower - Without Powered Convenience Outlet (Continued)

Size (Tons)	Nominal Unit Voltage	Compressor 1			Compressor 2			OD Fan Motors (each)	Supply Blower Motor	Pwr Exh Motor	Pwr Conv Outlet	Electric Heat Field Installed Kit 2EK045*			MCA <sup>1</sup> (Amps)	Min Fuse <sup>2</sup> / Breaker <sup>3</sup> Size (Amps)	Max Fuse <sup>2</sup> / Breaker <sup>3</sup> Size (Amps)	Min Discon-nect Rating <sup>4</sup>		MCA <sup>1</sup> w/Pwr Exh (Amps)	Min Fuse <sup>2</sup> / Breaker <sup>3</sup> Size w/ Pwr Exh (Amps)	Max Fuse <sup>2</sup> / Breaker <sup>3</sup> Size w/ Pwr Exh (Amps)	Min Discon-nect Rating <sup>4</sup> / Pwr Exh													
		RLA	LRA	MCC	RLA	LRA	MCC					Model	kW	Stages				Amps	FLA				LRA	FLA	LRA											
08 (7.5)	208-3-60	13.6	83.1	21	13.6	83.1	21	2.3	5.2	1.1		None	-	-	-	40.4	45	50	43	208	42.6	45	50	45	218											
												11725	12	1	33.3	48.1	50	50	44	208	50.9	60	60	47	218											
												12525	18.6	1	51.6	71	80	80	65	208	73.8	80	80	68	218											
												13225	24	1	66.6	89.8	90	90	83	208	92.5	100	100	85	218											
												14225	31.8	2	88.3	116.9	125	125	108	208	119.6	125	125	110	218											
	230-3-60	13.6	83.1	21	13.6	83.1	21	2.3	5.2	1		None	-	-	-	40.4	45	50	43	211	42.4	45	50	45	206											
												11725	16	1	38.5	54.6	60	60	50	211	57.1	60	60	53	206											
												12525	24.8	1	59.7	81.1	90	90	75	211	83.6	90	90	77	206											
												13225	32	1	77	102.8	110	110	95	211	105.3	110	110	97	206											
												14225	42.4	2	102	134	150	150	123	211	136.5	150	150	126	206											
	460-3-60	6.1	41	10	6.1	41	10	1.3	2.6	0.5		None	-	-	-	18.9	20	25	20	106	19.9	20	25	21	103											
												11746	16.5	1	19.8	28	30	30	26	106	29.3	30	30	27	103											
12846												27.8	1	33.4	45	45	45	41	106	46.3	50	50	43	103												
13346												33	1	39.7	52.9	60	60	49	106	54.1	60	60	50	103												
14246												41.7	2	50.2	66	70	70	61	106	67.3	70	70	62	103												
575-3-60	4.2	33	7	4.2	33	7	1.1	2	0.4		None	-	-	-	13.7	15	15	14	85	14.5	15	15	15	83												
											11758	17	1	16.4	23	25	25	21	85	24	25	25	22	83												
											13458	34	1	32.7	43.4	45	45	40	85	44.4	45	45	41	83												
											09 (8.5)	208-3-60	13.7	83.1	21	13.7	83.1	21	2.3	5.2	1.1		None	-	-	-	40.6	45	50	43	208	42.8	45	50	45	218
																							11725	12	1	33.3	48.1	50	50	44	208	50.9	60	60	47	218
12525	18.6	1	51.6	71	80	80	65	208	73.8	80													80	68	218											
13225	24	1	66.6	89.8	90	90	83	208	92.5	100													100	85	218											
14225	31.8	2	88.3	116.9	125	125	108	208	119.6	125													125	110	218											
230-3-60	13.7	83.1	21	13.7	83.1	21	2.3	5.2	1			None	-	-	-	40.6	45	50	43	211	42.6	45	50	45	206											
												11725	16	1	38.5	54.6	60	60	50	211	57.1	60	60	53	206											
												12525	24.8	1	59.7	81.1	90	90	75	211	83.6	90	90	77	206											
												13225	32	1	77	102.8	110	110	95	211	105.3	110	110	97	206											
												14225	42.4	2	102	134	150	150	123	211	136.5	150	150	126	206											
460-3-60	6.2	41	10	6.2	41	10	1.3	2.6	0.5			None	-	-	-	19.2	20	25	20	106	20.2	25	25	21	103											
												11746	16.5	1	19.8	28	30	30	26	106	29.3	30	30	27	103											
											12846	27.8	1	33.4	45	45	45	41	106	46.3	50	50	43	103												
											13346	33	1	39.7	52.9	60	60	49	106	54.1	60	60	50	103												
											14246	41.7	2	50.2	66	70	70	61	106	67.3	70	70	62	103												
575-3-60	4.8	33	8	4.8	33	8	1.1	2	0.4		None	-	-	-	15	20	20	16	85	15.8	20	20	17	83												
											11758	17	1	16.4	23	25	25	21	85	24	25	25	22	83												
											13458	34	1	32.7	43.4	45	45	40	85	44.4	45	45	41	83												
											12 (10)	208-3-60	16	110	25	16	110	25	5.8	10.2	1.1		None	-	-	-	52	60	60	55	305	54.2	60	60	58	315
																							11725	12	1	33.3	54.4	60	60	55	305	57.1	60	60	58	315
12525	18.6	1	51.6	77.3	80	80	71	305	80	90													90	74	315											
13225	24	1	66.6	96	100	100	88	305	98.8	100													100	91	315											
14225	31.8	2	88.3	123.1	125	125	113	305	125.9	150													150	116	315											
230-3-60	16	110	25	16	110	25	5.2	10.2	1			None	-	-	-	51.4	60	60	55	308	53.4	60	60	57	313											
												11725	16	1	38.5	60.9	70	70	56	308	63.4	70	70	58	313											
												12525	24.8	1	59.7	87.4	90	90	80	308	89.9	90	90	83	313											
												13225	32	1	77	109	110	110	100	308	111.5	125	125	103	313											
												14225	42.4	2	102	140.3	150	150	129	308	142.8	150	150	131	313											
460-3-60	7.8	52	12	7.8	52	12	2.9	4.8	0.5			None	-	-	-	25.3	30	30	27	150	26.3	30	30	28	152											
												11746	16.5	1	19.8	30.8	35	35	28	150	32	35	35	29	152											
											12846	27.8	1	33.4	47.8	50	50	44	150	49	50	50	45	152												
											13346	33	1	39.7	55.6	60	60	51	150	56.9	60	60	52	152												
											14246	41.7	2	50.2	68.8	70	70	63	150	70	70	70	64	152												
575-3-60	5.7	38.9	9	5.7	38.9	9	2.2	3.4	0.4		None	-	-	-	18.4	20	20	20	117	19.2	20	20	20	119												
											11758	17	1	16.4	24.8	25	25	23	117	25.8	30	30	24	119												
											13458	34	1	32.7	45.1	50	50	42	117	46.1	50	50	42	119												

**ZYE04-12 Medium Static Indoor Blower - Without Powered Convenience Outlet (Continued)**

Size (Tons)	Nominal Unit Voltage	Compressor 1			Compressor 2			OD Fan Motors (each)	Supply Blower Motor	Pwr Exh Motor	Pwr Conv Outlet	Electric Heat Field Installed Kit 2EK045*			MCA <sup>1</sup> (Amps)	Min Fuse <sup>2</sup> / Breaker <sup>3</sup> Size (Amps)	Max Fuse <sup>2</sup> / Breaker <sup>3</sup> Size (Amps)	Min Discon-nect Rating <sup>4</sup>		MCA <sup>1</sup> w/Pwr Exh (Amps)	Min Fuse <sup>2</sup> / Breaker <sup>3</sup> Size w/ Pwr Exh (Amps)	Max Fuse <sup>2</sup> / Breaker <sup>3</sup> Size w/ Pwr Exh (Amps)	Min Discon-nect Rating <sup>4</sup> / Pwr Exh			
		RLA	LRA	MCC	RLA	LRA	MCC					Model	kW	Stages				Amps	FLA				LRA	FLA	LRA	
<b>With VFD</b>																										
A7 (6)	208-3-60	17.6	136	27				2.3	8.9	1.1		None	-	-	-	35.5	40	50	36	207	37.7	40	50	38	212	
												10725	4.9	1	13.6	35.5	40	50	36	207	37.7	40	50	38	212	
												11725	12	1	33.3	52.8	60	60	49	207	55.5	60	60	51	212	
												12525	18.6	1	51.6	75.6	80	80	70	207	78.4	80	80	72	212	
	230-3-60	17.6	136	27				2.3	8.2	1			None	-	-	-	34.8	35	50	35	215	36.8	40	50	37	220
													10725	6.5	1	15.6	34.8	35	50	35	215	36.8	40	50	37	220
													11725	16	1	38.5	58.4	60	60	54	215	60.9	70	70	56	220
													12525	24.8	1	59.7	84.9	90	90	78	215	87.4	90	90	80	220
	460-3-60	8.5	66.1	13				1.3	4.1	0.5			None	-	-	-	17.3	20	25	17	106	18.3	20	25	19	109
													10746	6	1	7.2	17.3	20	25	13	106	18.3	20	25	14	109
													11746	16.5	1	19.8	29.9	30	30	27	106	31.1	35	35	29	109
													12646	25.5	1	30.7	43.5	45	45	40	106	44.8	45	45	41	109
575-3-60	6.3	55.3	10				1.1	3.2	0.4			None	-	-	-	13.3	15	15	13	86	14.1	15	15	14	88	
												11758	17	1	16.4	24.5	25	25	23	86	25.5	30	30	23	88	
												12658	25.7	1	24.7	34.9	35	35	32	86	35.9	40	40	33	88	
08 (7.5)	208-3-60	13.6	83.1	21	13.6	83.1	21	2.3	7	1.1		None	-	-	-	42.2	45	50	45	246	44.4	45	50	47	256	
												11725	12	1	33.3	50.4	60	60	46	246	53.1	60	60	49	256	
												12525	18.6	1	51.6	73.3	80	80	67	246	76	80	80	70	256	
												13225	24	1	66.6	92	100	100	85	246	94.8	100	100	87	256	
	230-3-60	13.6	83.1	21	13.6	83.1	21	2.3	7.2	1			None	-	-	-	42.4	45	50	45	248	44.4	45	50	47	243
													11725	16	1	38.5	57.1	60	60	53	248	59.6	60	60	55	243
													12525	24.8	1	59.7	83.6	90	90	77	248	86.1	90	90	79	243
													13225	32	1	77	105.3	110	110	97	248	107.8	110	110	99	243
	460-3-60	6.1	41	10	6.1	41	10	1.3	3.6	0.5			None	-	-	-	19.9	20	25	21	125	20.9	25	25	22	121
													11746	16.5	1	19.8	29.3	30	30	27	125	30.5	35	35	28	121
													12846	27.8	1	33.4	46.3	50	50	43	125	47.5	50	50	44	121
													13346	33	1	39.7	54.1	60	60	50	125	55.4	60	60	51	121
575-3-60	4.2	33	7	4.2	33	7	1.1	2.5	0.4			None	-	-	-	14.2	15	15	15	93	15	15	15	16	90	
												11758	17	1	16.4	23.6	25	25	22	93	24.6	25	25	23	90	
												13458	34	1	32.7	44	45	45	40	93	45	45	45	41	90	
												None	-	-	-	42.4	45	50	45	246	44.6	45	50	47	256	
09 (8.5)	208-3-60	13.7	83.1	21	13.7	83.1	21	2.3	7	1.1		None	-	-	-	42.4	45	50	45	246	44.6	45	50	47	256	
												11725	12	1	33.3	50.4	60	60	46	246	53.1	60	60	49	256	
												12525	18.6	1	51.6	73.3	80	80	67	246	76	80	80	70	256	
												13225	24	1	66.6	92	100	100	85	246	94.8	100	100	87	256	
	230-3-60	13.7	83.1	21	13.7	83.1	21	2.3	7.2	1			None	-	-	-	42.6	45	50	45	248	44.6	45	50	47	243
													11725	16	1	38.5	57.1	60	60	53	248	59.6	60	60	55	243
													12525	24.8	1	59.7	83.6	90	90	77	248	86.1	90	90	79	243
													13225	32	1	77	105.3	110	110	97	248	107.8	110	110	99	243
	460-3-60	6.2	41	10	6.2	41	10	1.3	3.6	0.5			None	-	-	-	20.2	25	25	21	125	21.2	25	25	23	121
													11746	16.5	1	19.8	29.3	30	30	27	125	30.5	35	35	28	121
													12846	27.8	1	33.4	46.3	50	50	43	125	47.5	50	50	44	121
													13346	33	1	39.7	54.1	60	60	50	125	55.4	60	60	51	121
575-3-60	4.8	33	8	4.8	33	8	1.1	2.5	0.4			None	-	-	-	15.5	20	20	16	93	16.3	20	20	17	90	
												11758	17	1	16.4	23.6	25	25	22	93	24.6	25	25	23	90	
												13458	34	1	32.7	44	45	45	40	93	45	45	45	41	90	
												None	-	-	-	42.4	45	50	45	246	44.6	45	50	47	256	

**ZYE04-12 Medium Static Indoor Blower - Without Powered Convenience Outlet (Continued)**

Size (Tons)	Nominal Unit Voltage	Compressor 1			Compressor 2			OD Fan Motors (each)	Supply Blower Motor	Pwr Exh Motor	Pwr Conv Outlet	Electric Heat Field Installed Kit 2EK045*			MCA <sup>1</sup> (Amps)	Min Fuse <sup>2</sup> / Breaker <sup>3</sup> Size (Amps)	Max Fuse <sup>2</sup> / Breaker <sup>3</sup> Size (Amps)	Min Discon- nect Rating <sup>4</sup>		MCA <sup>1</sup> w/Pwr Exh (Amps)	Min Fuse <sup>2</sup> / Breaker <sup>3</sup> Size w/ Pwr Exh (Amps)	Max Fuse <sup>2</sup> / Breaker <sup>3</sup> Size w/ Pwr Exh (Amps)	Min Discon- nect Rating <sup>4</sup> / Pwr Exh															
		RLA	LRA	MCC	RLA	LRA	MCC					Model	kW	Stages				Amps	FLA				LRA	FLA	LRA													
		12 (10)	208-3-60	16	110	25	16					110	25	5.8				9.9	1.1																	None	-	-
11725	12							1	33.3	54	60				60	55	315			56.8	60	60														57	325	
12525	18.6							1	51.6	76.9	80				80	71	315			79.6	80	80														73	325	
13225	24							1	66.6	95.6	100				100	88	315			98.4	100	100														91	325	
14225	31.8							2	88.3	122.8	125				125	113	315			125.5	150	150														115	325	
230-3-60	16		110	25	16	110	25	5.2	9.4	1															None	-	-	-	50.6	60	60	54	320	52.6	60	60	56	324
																									11725	16	1	38.5	59.9	60	60	55	320	62.4	70	70	57	324
																									12525	24.8	1	59.7	86.4	90	90	79	320	88.9	90	90	82	324
																									13225	32	1	77	108	110	110	99	320	110.5	125	125	102	324
																									14225	42.4	2	102	139.3	150	150	128	320	141.8	150	150	130	324
460-3-60	7.8		52	12	7.8	52	12	2.9	4.7	0.5															None	-	-	-	25.2	30	30	27	155	26.2	30	30	28	158
																									11746	16.5	1	19.8	30.6	35	35	28	155	31.9	35	35	29	158
																									12846	27.8	1	33.4	47.6	50	50	44	155	48.9	50	50	45	158
																									13346	33	1	39.7	55.5	60	60	51	155	56.8	60	60	52	158
																									14246	41.7	2	50.2	68.6	70	70	63	155	69.9	70	70	64	158
575-3-60	5.7		38.9	9	5.7	38.9	9	2.2	4.3	0.4														None	-	-	-	19.3	20	25	21	129	20.1	25	25	22	131	
																								11758	17	1	16.4	25.9	30	30	24	129	26.9	30	30	25	131	
																								13458	34	1	32.7	46.3	50	50	43	129	47.3	50	50	43	131	

1. Minimum Circuit Ampacity.
2. Dual Element, Time Delay Type.
3. HACR type per NEC.
4. Non-fused Disconnect, Verify on the unit nameplate that the disconnect is properly sized for the application. Units with field installed electric heat kits may exceed the factory installed disconnect amperage rating.

**ZYE04-12 Medium Static Indoor Blower - With Powered Convenience Outlet**

Size (Tons)	Nominal Unit Voltage	Compressor 1			Compressor 2			OD Fan Motors (each)	Supply Blower Motor	Pwr Exh Motor	Pwr Conv Outlet	Electric Heat Field Installed Kit 2EK045*				MCA <sup>1</sup> (Amps)	Min Fuse <sup>2</sup> / Breaker <sup>3</sup> Size (Amps)	Max Fuse <sup>2</sup> / Breaker <sup>3</sup> Size (Amps)	Min Discon-nect Rating <sup>4</sup>		MCA <sup>1</sup> w/Pwr Exh (Amps)	Min Fuse <sup>2</sup> / Breaker <sup>3</sup> Size w/ Pwr Exh (Amps)	Max Fuse <sup>2</sup> / Breaker <sup>3</sup> Size w/ Pwr Exh (Amps)	Min Discon-nect Rating <sup>4</sup> / Pwr Exh		
		RLA	LRA	MCC	RLA	LRA	MCC					Model	kW	Stages	Amps				FLA	LRA				FLA	LRA	
04 (3)	208-1-60	16.7	79	26				1.4	7.6	1.5	8.6	None	-	-	-	34.2	35	50	35	120	35.7	40	50	36	123	
												10625	4.9	1	23.6	44.4	45	50	41	120	46.3	50	50	43	123	
												11125	7.9	1	38	62.4	70	70	57	120	64.3	70	70	59	123	
	230-1-60	16.7	79	26				1.4	7	1.3	8.6	None	-	-	-	33.6	35	50	34	122	34.9	35	50	35	125	
												10625	6.5	1	27.1	48	50	50	44	122	49.6	50	50	46	125	
												11125	10.5	1	43.8	68.9	70	70	63	122	70.5	80	80	65	125	
	208-3-60	10.4	73	16				1.4	5.2	1.1	8.6	None	-	-	-	23.9	25	30	24	103	25	25	35	26	105	
												10625	4.9	1	13.6	28.9	30	30	27	103	30.3	35	35	28	105	
												11125	7.9	1	21.9	39.3	40	40	36	103	40.6	45	45	37	105	
	230-3-60	10.4	73	16				1.4	5.2	1	8.6	None	-	-	-	23.9	25	30	24	106	24.9	25	35	26	108	
												10625	6.5	1	15.6	31.4	35	35	29	106	32.6	35	35	30	108	
												11125	10.5	1	25.3	43.5	45	45	40	106	44.8	45	45	41	108	
	460-3-60	5.8	38	9				0.8	2.6	0.5	8.6	None	-	-	-	12.9	15	15	13	55	13.4	15	15	14	56	
												10646	6	1	7.2	14.9	15	15	14	55	15.6	20	20	14	56	
												11146	11.5	1	13.8	23.2	25	25	21	55	23.8	25	25	22	56	
	575-3-60	3.8	36.5	6				0.6	2	0.4	8.6	None	-	-	-	9.1	15	15	9	50	9.5	15	15	10	51	
												11058	9.2	1	8.9	15.8	20	20	15	50	16.3	20	20	15	51	
												11458	13.8	1	13.3	21.3	25	25	20	50	21.8	25	25	20	51	
	05 (4)	208-1-60	21.8	117	34				1.4	7.6	1.5	8.6	None	-	-	-	40.6	45	60	40	158	42.1	45	60	42	161
													10625	4.9	1	23.6	44.4	45	60	41	158	46.3	50	60	43	161
													11125	7.9	1	38	62.4	70	70	57	158	64.3	70	70	59	161
		230-1-60	21.8	117	34				1.4	7	1.3	8.6	None	-	-	-	40	40	60	40	160	41.3	45	60	41	163
													10625	6.5	1	27.1	48	50	60	44	160	49.6	50	60	46	163
													11125	10.5	1	43.8	68.9	70	70	63	160	70.5	80	80	65	163
208-3-60		13.7	83.1	21				1.4	5.2	1.1	8.6	None	-	-	-	28	30	40	28	113	29.1	30	40	30	116	
												10625	4.9	1	13.6	28.9	30	40	28	113	30.3	35	40	30	116	
												11125	7.9	1	21.9	39.3	40	40	36	113	40.6	45	45	37	116	
230-3-60		13.7	83.1	21				1.4	5.2	1	8.6	None	-	-	-	28	30	40	28	116	29	30	40	29	118	
												10625	6.5	1	15.6	31.4	35	40	29	116	32.6	35	40	30	118	
												11125	10.5	1	25.3	43.5	45	45	40	116	44.8	45	45	41	118	
460-3-60		6.2	41	10				0.8	2.6	0.5	8.6	None	-	-	-	13.4	15	15	14	58	13.9	15	15	14	59	
												10646	6	1	7.2	14.9	15	15	14	58	15.6	20	20	14	59	
												11146	11.5	1	13.8	23.2	25	25	21	58	23.8	25	25	22	59	
575-3-60		4.8	33	8				0.6	2	0.4	8.6	None	-	-	-	10.3	15	15	10	46	10.7	15	15	11	47	
												11058	9.2	1	8.9	15.8	20	20	15	46	16.3	20	20	15	47	
												11458	13.8	1	13.3	21.3	25	25	20	46	21.8	25	25	20	47	

**ZYE04-12 Medium Static Indoor Blower - With Powered Convenience Outlet (Continued)**

Size (Tons)	Nominal Unit Voltage	Compressor 1			Compressor 2			OD Fan Motors (each)	Supply Blower Motor	Pwr Exh Motor	Pwr Conv Outlet	Electric Heat Field Installed Kit 2EK045*			MCA <sup>1</sup> (Amps)	Min Fuse <sup>2/</sup> Breaker <sup>3</sup> Size (Amps)	Max Fuse <sup>2/</sup> Breaker <sup>3</sup> Size (Amps)	Min Discon-nect Rating <sup>4</sup>		MCA <sup>1</sup> w/Pwr Exh (Amps)	Min Fuse <sup>2/</sup> Breaker <sup>3</sup> Size w/ Pwr Exh (Amps)	Max Fuse <sup>2/</sup> Breaker <sup>3</sup> Size w/ Pwr Exh (Amps)	Min Discon-nect Rating <sup>4</sup> / Pwr Exh			
		RLA	LRA	MCC	RLA	LRA	MCC					Model	kW	Stages				Amps	FLA				LRA	FLA	LRA	
06 (5)	208-1-60	25	134	39				2.3	6.8	1.5	8.6	None	-	-	-	44.7	45	60	44	176	46.2	50	70	46	179	
												10625	4.9	1	23.6	44.7	45	60	44	176	46.2	50	70	46	179	
												11125	7.9	1	38	61.4	70	70	56	176	63.3	70	70	58	179	
	230-1-60	25	134	39				2.3	6.2	1.3	8.6	None	-	-	-	44.1	45	60	43	176	45.4	50	70	45	179	
												10625	6.5	1	27.1	47	50	60	43	176	48.6	50	70	45	179	
												11125	10.5	1	43.8	67.9	70	70	62	176	69.5	70	70	64	179	
	208-3-60	15.9	110	25				2.3	7	1.1	8.6	None	-	-	-	33.5	35	45	34	179	34.6	35	50	35	182	
												10625	4.9	1	13.6	33.5	35	45	34	179	34.6	35	50	35	182	
												11125	7.9	1	21.9	41.5	45	45	38	179	42.9	45	50	39	182	
	230-3-60	15.9	110	25				2.3	7.2	1	8.6	None	-	-	-	33.7	35	45	34	181	34.7	35	50	35	183	
												10625	6.5	1	15.6	33.9	35	45	34	181	35.1	40	50	35	183	
												11125	10.5	1	25.3	46	50	50	42	181	47.3	50	50	43	183	
	460-3-60	7.1	52	11				1.3	3.6	0.5	8.6	None	-	-	-	16	20	20	16	88	16.5	20	20	17	89	
												11146	6	1	7.2	16.2	20	20	15	88	16.8	20	20	15	89	
												11446	11.5	1	13.8	24.4	25	25	22	88	25.1	30	30	23	89	
	575-3-60	5.1	39.5	8				1.1	2.5	0.4	8.6	None	-	-	-	11.7	15	15	12	61	12.1	15	15	12	62	
												11458	13.8	1	13.3	21.9	25	25	20	61	22.4	25	25	21	62	
												12358	23	1	22.1	32.9	35	35	30	61	33.4	35	35	31	62	
	07 (6)	208-3-60	19	123	30			2.3	7.5	1.1	8.6	None	-	-	-	40.2	45	50	41	195	42.4	45	60	43	205	
												10725	4.9	1	13.6	40.2	45	50	41	195	42.4	45	60	43	205	
												11725	12	1	33.3	56.4	60	60	52	195	59.1	60	60	54	205	
												12525	18.6	1	51.6	79.3	80	80	73	195	82	90	90	75	205	
		230-3-60	19	123	30				2.3	7.5	1	8.6	None	-	-	-	40.2	45	50	41	202	42.2	45	60	43	197
													10725	6.5	1	15.6	40.2	45	50	41	202	42.2	45	60	43	197
11725													16	1	38.5	62.9	70	70	58	202	65.4	70	70	60	197	
12525													24.8	1	59.7	89.4	90	90	82	202	91.9	100	100	85	197	
460-3-60		9.7	62	15				1.3	3.4	0.5	8.6	None	-	-	-	20.3	25	30	21	103	21.3	25	30	22	100	
												10746	6	1	7.2	20.3	25	30	15	103	21.3	25	30	16	100	
												11746	16.5	1	19.8	31.7	35	35	29	103	32.9	35	35	30	100	
												12646	25.5	1	30.7	45.3	50	50	42	103	46.6	50	50	43	100	
575-3-60		7.4	50	12				1.1	2.8	0.4	8.6	None	-	-	-	16	20	20	16	83	16.8	20	20	17	80	
												11758	17	1	16.4	26.2	30	30	24	83	27.2	30	30	25	80	
												12658	25.7	1	24.7	36.5	40	40	34	83	37.5	40	40	35	80	
												None	-	-	-	38.4	40	50	39	199	40.6	45	50	42	204	
A7 (6)		208-3-60	17.6	136	27			2.3	7.5	1.1	8.6	10725	4.9	1	13.6	38.4	40	50	39	199	40.6	45	50	42	204	
												11725	12	1	33.3	56.4	60	60	52	199	59.1	60	60	54	204	
												12525	18.6	1	51.6	79.3	80	80	73	199	82	90	90	75	204	
												None	-	-	-	38.4	40	50	39	205	40.4	45	50	41	210	
		230-3-60	17.6	136	27				2.3	7.5	1	8.6	10725	6.5	1	15.6	38.4	40	50	39	205	40.4	45	50	41	210
													11725	16	1	38.5	62.9	70	70	58	205	65.4	70	70	60	210
													12525	24.8	1	59.7	89.4	90	90	82	205	91.9	100	100	85	210
													None	-	-	-	18.8	20	25	19	102	19.8	20	25	20	104
	460-3-60	8.5	66.1	13				1.3	3.4	0.5	8.6	10746	6	1	7.2	18.8	20	25	15	102	19.8	20	25	16	104	
												11746	16.5	1	19.8	31.7	35	35	29	102	32.9	35	35	30	104	
												12646	25.5	1	30.7	45.3	50	50	42	102	46.6	50	50	43	104	
												None	-	-	-	14.6	15	20	15	84	15.4	20	20	16	86	
	575-3-60	6.3	55.3	10				1.1	2.8	0.4	8.6	11758	17	1	16.4	26.2	30	30	24	84	27.2	30	30	25	86	
												12658	25.7	1	24.7	36.5	40	40	34	84	37.5	40	40	35	86	

ZYE04-12 Medium Static Indoor Blower - With Powered Convenience Outlet (Continued)

Size (Tons)	Nominal Unit Voltage	Compressor 1			Compressor 2			OD Fan Motors (each)	Supply Blower Motor	Pwr Exh Motor	Pwr Conv Outlet	Electric Heat Field Installed Kit 2EK045*				MCA <sup>1</sup> (Amps)	Min Fuse <sup>2</sup> / Breaker <sup>3</sup> Size (Amps)	Max Fuse <sup>2</sup> / Breaker <sup>3</sup> Size (Amps)	Min Disconnect Rating <sup>4</sup>		MCA <sup>1</sup> w/Pwr Exh (Amps)	Min Fuse <sup>2</sup> / Breaker <sup>3</sup> Size w/ Pwr Exh (Amps)	Max Fuse <sup>2</sup> / Breaker <sup>3</sup> Size w/ Pwr Exh (Amps)	Min Disconnect Rating <sup>6</sup> / Pwr Exh	
		RLA	LRA	MCC	RLA	LRA	MCC					Model	kW	Stages	Amps				FLA	LRA				FLA	LRA
08 (7.5)	208-3-60	13.6	83.1	21	13.6	83.1	21	2.3	5.2	1.1	8.6	None	-	-	-	44.7	45	50	47	212	46.9	50	50	50	222
												11725	12	1	33.3	53.5	60	60	49	212	56.3	60	60	52	222
												12525	18.6	1	51.6	76.4	80	80	70	212	79.1	80	80	73	222
												13225	24	1	66.6	95.1	100	100	88	212	97.9	100	100	90	222
												14225	31.8	2	88.3	122.3	125	125	112	212	125	150	150	115	222
	230-3-60	13.6	83.1	21	13.6	83.1	21	2.3	5.2	1	8.6	None	-	-	-	44.7	45	50	47	216	46.7	50	60	50	210
												11725	16	1	38.5	60	60	60	55	216	62.5	70	70	58	210
												12525	24.8	1	59.7	86.5	90	90	80	216	89	90	90	82	210
												13225	32	1	77	108.1	110	110	99	216	110.6	125	125	102	210
												14225	42.4	2	102	139.4	150	150	128	216	141.9	150	150	131	210
	460-3-60	6.1	41	10	6.1	41	10	1.3	2.6	0.5	8.6	None	-	-	-	21.1	25	25	23	108	22.1	25	25	24	105
												11746	16.5	1	19.8	30.7	35	35	28	108	31.9	35	35	29	105
12846												27.8	1	33.4	47.7	50	50	44	108	48.9	50	50	45	105	
13346												33	1	39.7	55.6	60	60	51	108	56.8	60	60	52	105	
14246												41.7	2	50.2	68.7	70	70	63	108	69.9	70	70	64	105	
575-3-60	4.2	33	7	4.2	33	7	1.1	2	0.4	8.6	None	-	-	-	15.4	20	20	16	87	16.2	20	20	17	84	
											11758	17	1	16.4	25.2	30	30	23	87	26.2	30	30	24	84	
											13458	34	1	32.7	45.5	50	50	42	87	46.5	50	50	43	84	
09 (8.5)	208-3-60	13.7	83.1	21	13.7	83.1	21	2.3	5.2	1.1	8.6	None	-	-	-	44.9	45	50	48	212	47.1	50	50	50	222
												11725	12	1	33.3	53.5	60	60	49	212	56.3	60	60	52	222
												12525	18.6	1	51.6	76.4	80	80	70	212	79.1	80	80	73	222
												13225	24	1	66.6	95.1	100	100	88	212	97.9	100	100	90	222
												14225	31.8	2	88.3	122.3	125	125	112	212	125	150	150	115	222
	230-3-60	13.7	83.1	21	13.7	83.1	21	2.3	5.2	1	8.6	None	-	-	-	44.9	45	50	48	216	46.9	50	60	50	210
												11725	16	1	38.5	60	60	60	55	216	62.5	70	70	58	210
												12525	24.8	1	59.7	86.5	90	90	80	216	89	90	90	82	210
												13225	32	1	77	108.1	110	110	99	216	110.6	125	125	102	210
												14225	42.4	2	102	139.4	150	150	128	216	141.9	150	150	131	210
	460-3-60	6.2	41	10	6.2	41	10	1.3	2.6	0.5	8.6	None	-	-	-	21.4	25	25	23	108	22.4	25	25	24	105
												11746	16.5	1	19.8	30.7	35	35	28	108	31.9	35	35	29	105
12846												27.8	1	33.4	47.7	50	50	44	108	48.9	50	50	45	105	
13346												33	1	39.7	55.6	60	60	51	108	56.8	60	60	52	105	
14246												41.7	2	50.2	68.7	70	70	63	108	69.9	70	70	64	105	
575-3-60	4.8	33	8	4.8	33	8	1.1	2	0.4	8.6	None	-	-	-	16.7	20	20	18	87	17.5	20	20	19	84	
											11758	17	1	16.4	25.2	30	30	23	87	26.2	30	30	24	84	
											13458	34	1	32.7	45.5	50	50	42	87	46.5	50	50	43	84	
12 (10)	208-3-60	16	110	25	16	110	25	5.8	10.2	1.1	8.6	None	-	-	-	56.3	60	70	60	310	58.5	60	70	63	320
												11725	12	1	33.3	59.8	60	70	60	310	62.5	70	70	63	320
												12525	18.6	1	51.6	82.6	90	90	76	310	85.4	90	90	79	320
												13225	24	1	66.6	101.4	110	110	93	310	104.1	110	110	96	320
												14225	31.8	2	88.3	128.5	150	150	118	310	131.3	150	150	121	320
	230-3-60	16	110	25	16	110	25	5.2	10.2	1	8.6	None	-	-	-	55.7	60	70	59	312	57.7	60	70	62	317
												11725	16	1	38.5	66.3	70	70	61	312	68.8	70	70	63	317
												12525	24.8	1	59.7	92.8	100	100	85	312	95.3	100	100	88	317
												13225	32	1	77	114.4	125	125	105	312	116.9	125	125	108	317
												14225	42.4	2	102	145.6	150	150	134	312	148.1	150	150	136	317
	460-3-60	7.8	52	12	7.8	52	12	2.9	4.8	0.5	8.6	None	-	-	-	27.5	30	35	29	152	28.5	30	35	30	154
												11746	16.5	1	19.8	33.4	35	35	31	152	34.7	35	35	32	154
12846												27.8	1	33.4	50.4	60	60	46	152	51.7	60	60	48	154	
13346												33	1	39.7	58.3	60	60	54	152	59.6	60	60	55	154	
14246												41.7	2	50.2	71.4	80	80	66	152	72.7	80	80	67	154	
575-3-60	5.7	38.9	9	5.7	38.9	9	2.2	3.4	0.4	8.6	None	-	-	-	20.1	25	25	22	118	20.9	25	25	22	120	
											11758	17	1	16.4	26.9	30	30	25	118	27.9	30	30	26	120	
											13458	34	1	32.7	47.3	50	50	43	118	48.3	50	50	44	120	

**ZYE04-12 Medium Static Indoor Blower - With Powered Convenience Outlet (Continued)**

Size (Tons)	Nominal Unit Voltage	Compressor 1			Compressor 2			OD Fan Motors (each)	Supply Blower Motor	Pwr Exh Motor	Pwr Conv Outlet	Electric Heat Field Installed Kit 2EK045*			MCA <sup>1</sup> (Amps)	Min Fuse <sup>2</sup> / Breaker <sup>3</sup> Size (Amps)	Max Fuse <sup>2</sup> / Breaker <sup>3</sup> Size (Amps)	Min Disconnect Rating <sup>4</sup>		MCA <sup>1</sup> w/Pwr Exh (Amps)	Min Fuse <sup>2</sup> / Breaker <sup>3</sup> Size w/ Pwr Exh (Amps)	Max Fuse <sup>2</sup> / Breaker <sup>3</sup> Size w/ Pwr Exh (Amps)	Min Disconnect Rating <sup>4</sup> / Pwr Exh		
		RLA	LRA	MCC	RLA	LRA	MCC					Model	kW	Stages				Amps	FLA				LRA	FLA	LRA
<b>With VFD</b>																									
A7 (6)	208-3-60	17.6	136	27				2.3	8.9	1.1	8.6	None	-	-	-	39.8	40	50	41	212	42	45	50	43	217
												10725	4.9	1	13.6	39.8	40	50	41	212	42	45	50	43	217
												11725	12	1	33.3	58.1	60	60	53	212	60.9	70	70	56	217
												12525	18.6	1	51.6	81	90	90	75	212	83.8	90	90	77	217
	230-3-60	17.6	136	27				2.3	8.2	1	8.6	None	-	-	-	39.1	40	50	40	219	41.1	45	50	42	224
												10725	6.5	1	15.6	39.1	40	50	40	219	41.1	45	50	42	224
												11725	16	1	38.5	63.8	70	70	59	219	66.3	70	70	61	224
												12525	24.8	1	59.7	90.3	100	100	83	219	92.8	100	100	85	224
	460-3-60	8.5	66.1	13				1.3	4.1	0.5	8.6	None	-	-	-	19.5	20	25	20	109	20.5	25	25	21	111
												10746	6	1	7.2	19.5	20	25	15	109	20.5	25	25	17	111
												11746	16.5	1	19.8	32.6	35	35	30	109	33.8	35	35	31	111
												12646	25.5	1	30.7	46.2	50	50	42	109	47.4	50	50	44	111
575-3-60	6.3	55.3	10				1.1	3.2	0.4	8.6	None	-	-	-	15	20	20	15	88	15.8	20	20	16	90	
											11758	17	1	16.4	26.7	30	30	25	88	27.7	30	30	25	90	
											12658	25.7	1	24.7	37	40	40	34	88	38	40	40	35	90	
08 (7.5)	208-3-60	13.6	83.1	21	13.6	83.1	21	2.3	7	1.1	8.6	None	-	-	-	46.5	50	60	50	250	48.7	50	60	52	260
												11725	12	1	33.3	55.8	60	60	51	250	58.5	60	60	54	260
												12525	18.6	1	51.6	78.6	80	80	72	250	81.4	90	90	75	260
												13225	24	1	66.6	97.4	100	100	90	250	100.1	110	110	92	260
	230-3-60	13.6	83.1	21	13.6	83.1	21	2.3	7.2	1	8.6	None	-	-	-	46.7	50	60	50	252	48.7	50	60	52	247
												11725	16	1	38.5	62.5	70	70	58	252	65	70	70	60	247
												12525	24.8	1	59.7	89	90	90	82	252	91.5	100	100	84	247
												13225	32	1	77	110.6	125	125	102	252	113.1	125	125	104	247
	460-3-60	6.1	41	10	6.1	41	10	1.3	3.6	0.5	8.6	None	-	-	-	22.1	25	25	24	127	23.1	25	25	25	123
												11746	16.5	1	19.8	31.9	35	35	29	127	33.2	35	35	31	123
												12846	27.8	1	33.4	48.9	50	50	45	127	50.2	60	60	46	123
												13346	33	1	39.7	56.8	60	60	52	127	58.1	60	60	53	123
575-3-60	4.2	33	7	4.2	33	7	1.1	2.5	0.4	8.6	None	-	-	-	15.9	20	20	17	95	16.7	20	20	18	92	
											11758	17	1	16.4	25.8	30	30	24	95	26.8	30	30	25	92	
											13458	34	1	32.7	46.2	50	50	42	95	47.2	50	50	43	92	
											None	-	-	-	46.7	50	60	50	250	48.9	50	60	52	260	
09 (8.5)	208-3-60	13.7	83.1	21	13.7	83.1	21	2.3	7	1.1	8.6	None	-	-	-	46.7	50	60	50	250	48.9	50	60	52	260
												11725	12	1	33.3	55.8	60	60	51	250	58.5	60	60	54	260
												12525	18.6	1	51.6	78.6	80	80	72	250	81.4	90	90	75	260
												13225	24	1	66.6	97.4	100	100	90	250	100.1	110	110	92	260
	230-3-60	13.7	83.1	21	13.7	83.1	21	2.3	7.2	1	8.6	None	-	-	-	46.9	50	60	50	252	48.9	50	60	52	247
												11725	16	1	38.5	62.5	70	70	58	252	65	70	70	60	247
												12525	24.8	1	59.7	89	90	90	82	252	91.5	100	100	84	247
												13225	32	1	77	110.6	125	125	102	252	113.1	125	125	104	247
	460-3-60	6.2	41	10	6.2	41	10	1.3	3.6	0.5	8.6	None	-	-	-	22.4	25	25	24	127	23.4	25	25	25	123
												11746	16.5	1	19.8	31.9	35	35	29	127	33.2	35	35	31	123
												12846	27.8	1	33.4	48.9	50	50	45	127	50.2	60	60	46	123
												13346	33	1	39.7	56.8	60	60	52	127	58.1	60	60	53	123
575-3-60	4.8	33	8	4.8	33	8	1.1	2.5	0.4	8.6	None	-	-	-	17.2	20	20	18	95	18	20	20	19	92	
											11758	17	1	16.4	25.8	30	30	24	95	26.8	30	30	25	92	
											13458	34	1	32.7	46.2	50	50	42	95	47.2	50	50	43	92	
											None	-	-	-	46.7	50	60	50	250	48.9	50	60	52	260	

**ZYE04-12 Medium Static Indoor Blower - With Powered Convenience Outlet (Continued)**

Size (Tons)	Nominal Unit Voltage	Compressor 1			Compressor 2			OD Fan Motors (each)	Supply Blower Motor	Pwr Exh Motor	Pwr Conv Outlet	Electric Heat Field Installed Kit 2EK045*				MCA <sup>1</sup> (Amps)	Min Fuse <sup>2</sup> / Breaker <sup>3</sup> Size (Amps)	Max Fuse <sup>2</sup> / Breaker <sup>3</sup> Size (Amps)	Min Disconnect Rating <sup>4</sup>		MCA <sup>1</sup> w/Pwr Exh (Amps)	Min Fuse <sup>2</sup> / Breaker <sup>3</sup> Size w/ Pwr Exh (Amps)	Max Fuse <sup>2</sup> / Breaker <sup>3</sup> Size w/ Pwr Exh (Amps)	Min Disconnect Rating <sup>4</sup> / Pwr Exh	
		RLA	LRA	MCC	RLA	LRA	MCC					Model	kW	Stages	Amps				FLA	LRA				FLA	LRA
12 (10)	208-3-60	16	110	25	16	110	25	5.8	9.9	1.1	8.6	None	-	-	-	56	60	70	60	319	58.2	60	70	62	329
												11725	12	1	33.3	59.4	60	70	60	319	62.1	70	70	62	329
												12525	18.6	1	51.6	82.3	90	90	76	319	85	90	90	78	329
												13225	24	1	66.6	101	110	110	93	319	103.8	110	110	95	329
												14225	31.8	2	88.3	128.1	150	150	118	319	130.9	150	150	120	329
	230-3-60	16	110	25	16	110	25	5.2	9.4	1	8.6	None	-	-	-	54.9	60	70	59	324	56.9	60	70	61	329
												11725	16	1	38.5	65.3	70	70	60	324	67.8	70	70	62	329
												12525	24.8	1	59.7	91.8	100	100	84	324	94.3	100	100	87	329
												13225	32	1	77	113.4	125	125	104	324	115.9	125	125	107	329
												14225	42.4	2	102	144.6	150	150	133	324	147.1	150	150	135	329
	460-3-60	7.8	52	12	7.8	52	12	2.9	4.7	0.5	8.6	None	-	-	-	27.4	30	35	29	157	28.4	30	35	30	160
												11746	16.5	1	19.8	33.3	35	35	31	157	34.6	35	35	32	160
												12846	27.8	1	33.4	50.3	60	60	46	157	51.6	60	60	47	160
												13346	33	1	39.7	58.2	60	60	54	157	59.4	60	60	55	160
												14246	41.7	2	50.2	71.3	80	80	66	157	72.6	80	80	67	160
	575-3-60	5.7	38.9	9	5.7	38.9	9	2.2	4.3	0.4	8.6	None	-	-	-	21	25	25	23	131	21.8	25	25	23	133
												11758	17	1	16.4	28	30	30	26	131	29	30	30	27	133
												13458	34	1	32.7	48.4	50	50	45	131	49.4	50	50	45	133

1. Minimum Circuit Ampacity.
2. Dual Element, Time Delay Type.
3. HACR type per NEC.
4. Non-fused Disconnect, Verify on the unit nameplate that the disconnect is properly sized for the application. Units with field installed electric heat kits may exceed the factory installed disconnect amperage rating.



**ZYE04-12 High Static Indoor Blower - Without Powered Convenience Outlet**

Size (Tons)	Nominal Unit Voltage	Compressor 1			Compressor 2			OD Fan Motors (each)	Supply Blower Motor	Pwr Exh Motor	Pwr Conv Outlet	Electric Heat Field Installed Kit 2EK045*				MCA <sup>1</sup> (Amps)	Min Fuse <sup>2</sup> /Breaker <sup>3</sup> Size (Amps)	Max Fuse <sup>2</sup> /Breaker <sup>3</sup> Size (Amps)	Min Discon-nect Rating <sup>4</sup>		MCA <sup>1</sup> w/Pwr Exh (Amps)	Min Fuse <sup>2</sup> /Breaker <sup>3</sup> Size w/ Pwr Exh (Amps)	Max Fuse <sup>2</sup> /Breaker <sup>3</sup> Size w/ Pwr Exh (Amps)	Min Discon-nect Rating <sup>4</sup> / Pwr Exh		
		RLA	LRA	MCC	RLA	LRA	MCC					Model	kW	Stages	Amps				FLA	LRA				FLA	LRA	
04 (3)	208-3-60	10.4	73	16				1.4	5.2	1.1		None	-	-	-	19.6	20	30	20	99	20.7	25	30	21	101	
												10625	4.9	1	13.6	23.5	25	30	22	99	24.9	25	30	23	101	
												11125	7.9	1	21.9	33.9	35	35	31	99	35.3	40	40	32	101	
												11625	12	1	33.3	48.1	50	50	44	99	49.5	50	50	46	101	
	230-3-60	10.4	73	16				1.4	5.2	1			None	-	-	-	19.6	20	30	20	101	20.6	25	30	21	104
													10625	6.5	1	15.6	26	30	30	24	101	27.3	30	30	25	104
													11125	10.5	1	25.3	38.1	40	40	35	101	39.4	40	40	36	104
													11625	16	1	38.5	54.6	60	60	50	101	55.9	60	60	51	104
	460-3-60	5.8	38	9				0.8	2.6	0.5			None	-	-	-	10.7	15	15	11	52	11.2	15	15	11	54
													10646	6	1	7.2	12.3	15	15	11	52	12.9	15	15	12	54
													11146	11.5	1	13.8	20.5	25	25	19	52	21.1	25	25	19	54
													11446	14	1	16.8	24.3	25	25	22	52	24.9	25	25	23	54
575-3-60	3.8	36.5	6				0.6	2	0.4			None	-	-	-	7.4	15	15	7	48	7.8	15	15	8	49	
												11058	9.2	1	8.9	13.6	15	15	13	48	14.1	15	15	13	49	
												11458	13.8	1	13.3	19.1	20	20	18	48	19.6	20	20	18	49	
												None	-	-	-	26	30	35	26	135	27.1	30	40	27	137	
05 (4)	208-3-60	13.7	83.1	21				1.4	7.5	1.1		10625	4.9	1	13.6	26.4	30	35	26	135	27.8	30	40	27	137	
												11125	7.9	1	21.9	36.8	40	40	34	135	38.1	40	40	35	137	
												11625	12	1	33.3	51	60	60	47	135	52.4	60	60	48	137	
												None	-	-	-	26	30	35	26	141	27	30	40	27	144	
	230-3-60	13.7	83.1	21				1.4	7.5	1			10625	6.5	1	15.6	28.9	30	35	27	141	30.1	35	40	28	144
													11125	10.5	1	25.3	41	45	45	38	141	42.3	45	45	39	144
													11625	16	1	38.5	57.5	60	60	53	141	58.8	60	60	54	144
													None	-	-	-	12	15	15	12	70	12.5	15	15	13	72
	460-3-60	6.2	41	10				0.8	3.4	0.5			10646	6	1	7.2	13.3	15	15	12	70	13.9	15	15	13	72
													11146	11.5	1	13.8	21.5	25	25	20	70	22.1	25	25	20	72
													11446	14	1	16.8	25.3	30	30	23	70	25.9	30	30	24	72
													None	-	-	-	9.4	15	15	9	57	9.8	15	15	10	57
575-3-60	4.8	33	8				0.6	2.8	0.4			11058	9.2	1	8.9	14.6	15	15	13	57	15.1	20	20	14	57	
												11458	13.8	1	13.3	20.1	25	25	19	57	20.6	25	25	19	57	
												None	-	-	-	31.1	35	45	31	192	32.2	35	45	32	194	
												10625	4.9	1	13.6	31.1	35	45	31	192	32.2	35	45	32	194	
06 (5)	208-3-60	15.9	110	25				2.3	8.9	1.1		11125	7.9	1	21.9	38.5	40	45	35	192	39.9	40	45	37	194	
												11625	12	1	33.3	52.8	60	60	49	192	54.1	60	60	50	194	
												None	-	-	-	30.4	35	45	30	194	31.4	35	45	32	196	
												10625	6.5	1	15.6	30.4	35	45	30	194	31.4	35	45	32	196	
	230-3-60	15.9	110	25				2.3	8.2	1			11125	10.5	1	25.3	41.9	45	45	39	194	43.1	45	45	40	196
													11625	16	1	38.5	58.4	60	60	54	194	59.6	60	60	55	196
													None	-	-	-	14.3	15	20	14	89	14.8	15	20	15	91
													11146	6	1	7.2	14.3	15	20	13	89	14.8	15	20	14	91
	460-3-60	7.1	52	11				1.3	4.1	0.5			11146	11.5	1	13.8	22.4	25	25	21	89	23	25	25	21	91
													11446	14	1	16.8	26.1	30	30	24	89	26.8	30	30	25	91
													None	-	-	-	10.7	15	15	11	68	11.1	15	15	11	69
													11458	13.8	1	13.3	20.6	25	25	19	68	21.1	25	25	19	69
575-3-60	5.1	39.5	8				1.1	3.2	0.4			12358	23	1	22.1	31.6	35	35	29	68	32.1	35	35	30	69	

ZYE04-12 High Static Indoor Blower - Without Powered Convenience Outlet (Continued)

Size (Tons)	Nominal Unit Voltage	Compressor 1			Compressor 2			OD Fan Motors (each)	Supply Blower Motor	Pwr Exh Motor	Pwr Conv Outlet	Electric Heat Field Installed Kit 2EK045*			MCA <sup>1</sup> (Amps)	Min Fuse <sup>2</sup> / Breaker <sup>3</sup> Size (Amps)	Max Fuse <sup>2</sup> / Breaker <sup>3</sup> Size (Amps)	Min Disconnect Rating <sup>4</sup>		MCA <sup>1</sup> w/Pwr Exh (Amps)	Min Fuse <sup>2</sup> / Breaker <sup>3</sup> Size w/ Pwr Exh (Amps)	Max Fuse <sup>2</sup> / Breaker <sup>3</sup> Size w/ Pwr Exh (Amps)	Min Disconnect Rating <sup>4</sup> / Pwr Exh			
		RLA	LRA	MCC	RLA	LRA	MCC					Model	kW	Stages				Amps	FLA				LRA	FLA	LRA	
07 (6)	208-3-60	19	123	30				2.3	10.2	1.1		None	-	-	-	38.6	40	50	39	206	40.8	45	50	41	216	
												10725	4.9	1	13.6	38.6	40	50	39	206	40.8	45	50	41	216	
												11725	12	1	33.3	54.4	60	60	50	206	57.1	60	60	53	216	
												12525	18.6	1	51.6	77.3	80	80	71	206	80	90	90	74	216	
	230-3-60	19	123	30				2.3	10.2	1			None	-	-	-	38.6	40	50	39	212	40.6	45	50	41	207
													10725	6.5	1	15.6	38.6	40	50	39	212	40.6	45	50	41	207
													11725	16	1	38.5	60.9	70	70	56	212	63.4	70	70	58	207
													12525	24.8	1	59.7	87.4	90	90	80	212	89.9	90	90	83	207
	460-3-60	9.7	62	15				1.3	4.8	0.5			None	-	-	-	19.5	20	25	20	108	20.5	25	25	21	105
													10746	6	1	7.2	19.5	20	25	14	108	20.5	25	25	15	105
													11746	16.5	1	19.8	30.8	35	35	28	108	32	35	35	29	105
													12646	25.5	1	30.7	44.4	45	45	41	108	45.6	50	50	42	105
575-3-60	7.4	50	12				1.1	3.4	0.4			None	-	-	-	14.9	15	20	15	87	15.7	20	20	16	84	
												11758	17	1	16.4	24.8	25	25	23	87	25.8	30	30	24	84	
												12658	25.7	1	24.7	35.1	40	40	32	87	36.1	40	40	33	84	
A7 (6)	208-3-60	17.6	136	27				2.3	10.2	1.1		None	-	-	-	36.8	40	50	37	209	39	40	50	40	214	
												10725	4.9	1	13.6	36.8	40	50	37	209	39	40	50	40	214	
												11725	12	1	33.3	54.4	60	60	50	209	57.1	60	60	53	214	
												12525	18.6	1	51.6	77.3	80	80	71	209	80	90	90	74	214	
	230-3-60	17.6	136	27				2.3	10.2	1			None	-	-	-	36.8	40	50	37	215	38.8	40	50	40	220
													10725	6.5	1	15.6	36.8	40	50	37	215	38.8	40	50	40	220
													11725	16	1	38.5	60.9	70	70	56	215	63.4	70	70	58	220
													12525	24.8	1	59.7	87.4	90	90	80	215	89.9	90	90	83	220
	460-3-60	8.5	66.1	13				1.3	4.8	0.5			None	-	-	-	18	20	25	18	106	19	20	25	19	109
													10746	6	1	7.2	18	20	25	14	106	19	20	25	15	109
													11746	16.5	1	19.8	30.8	35	35	28	106	32	35	35	29	109
													12646	25.5	1	30.7	44.4	45	45	41	106	45.6	50	50	42	109
575-3-60	6.3	55.3	10				1.1	3.4	0.4			None	-	-	-	13.5	15	15	14	88	14.3	15	15	15	89	
												11758	17	1	16.4	24.8	25	25	23	88	25.8	30	30	24	89	
												12658	25.7	1	24.7	35.1	40	40	32	88	36.1	40	40	33	89	
08 (7.5)	208-3-60	13.6	83.1	21	13.6	83.1	21	2.3	10.2	1.1		None	-	-	-	45.4	50	50	48	249	47.6	50	60	51	259	
												11725	12	1	33.3	54.4	60	60	50	249	57.1	60	60	53	259	
												12525	18.6	1	51.6	77.3	80	80	71	249	80	90	90	74	259	
												13225	24	1	66.6	96	100	100	88	249	98.8	100	100	91	259	
	230-3-60	13.6	83.1	21	13.6	83.1	21	2.3	10.2	1			None	-	-	-	45.4	50	50	48	255	47.4	50	60	51	250
													11725	16	1	38.5	60.9	70	70	56	255	63.4	70	70	58	250
													12525	24.8	1	59.7	87.4	90	90	80	255	89.9	90	90	83	250
													13225	32	1	77	109	110	110	100	255	111.5	125	125	103	250
	460-3-60	6.1	41	10	6.1	41	10	1.3	4.8	0.5			None	-	-	-	21.1	25	25	23	128	22.1	25	25	24	125
													11746	16.5	1	19.8	30.8	35	35	28	128	32	35	35	29	125
													12846	27.8	1	33.4	47.8	50	50	44	128	49	50	50	45	125
													13346	33	1	39.7	55.6	60	60	51	128	56.9	60	60	52	125
575-3-60	4.2	33	7	4.2	33	7	1.1	3.4	0.4			None	-	-	-	15.1	20	20	16	103	15.9	20	20	17	100	
												11758	17	1	16.4	24.8	25	25	23	103	25.8	30	30	24	100	
												13458	34	1	32.7	45.1	50	50	42	103	46.1	50	50	42	100	

**ZYE04-12 High Static Indoor Blower - Without Powered Convenience Outlet (Continued)**

Size (Tons)	Nominal Unit Voltage	Compressor 1			Compressor 2			OD Fan Motors (each)	Supply Blower Motor	Pwr Exh Motor	Pwr Conv Outlet	Electric Heat Field Installed Kit 2EK045*				MCA <sup>1</sup> (Amps)	Min Fuse <sup>2</sup> / Breaker <sup>3</sup> Size (Amps)	Max Fuse <sup>2</sup> / Breaker <sup>3</sup> Size (Amps)	Min Disconnect Rating <sup>4</sup>		MCA <sup>1</sup> w/Pwr Exh (Amps)	Min Fuse <sup>2</sup> / Breaker <sup>3</sup> Size w/ Pwr Exh (Amps)	Max Fuse <sup>2</sup> / Breaker <sup>3</sup> Size w/ Pwr Exh (Amps)	Min Disconnect Rating <sup>5</sup> / Pwr Exh	
		RLA	LRA	MCC	RLA	LRA	MCC					Model	kW	Stages	Amps				FLA	LRA				FLA	LRA
09 (8.5)	208-3-60	13.7	83.1	21	13.7	83.1	21	2.3	10.2	1.1	None	-	-	-	45.6	50	50	49	249	47.8	50	60	51	259	
											11725	12	1	33.3	54.4	60	60	50	249	57.1	60	60	53	259	
											12525	18.6	1	51.6	77.3	80	80	71	249	80	90	90	74	259	
											13225	24	1	66.6	96	100	100	88	249	98.8	100	100	91	259	
											14225	31.8	2	88.3	123.1	125	125	113	249	125.9	150	150	116	259	
	230-3-60	13.7	83.1	21	13.7	83.1	21	2.3	10.2	1	None	-	-	-	45.6	50	50	49	255	47.6	50	60	51	250	
											11725	16	1	38.5	60.9	70	70	56	255	63.4	70	70	58	250	
											12525	24.8	1	59.7	87.4	90	90	80	255	89.9	90	90	83	250	
											13225	32	1	77	109	110	110	100	255	111.5	125	125	103	250	
											14225	42.4	2	102	140.3	150	150	129	255	142.8	150	150	131	250	
	460-3-60	6.2	41	10	6.2	41	10	1.3	4.8	0.5	None	-	-	-	21.4	25	25	23	128	22.4	25	25	24	125	
											11746	16.5	1	19.8	30.8	35	35	28	128	32	35	35	29	125	
12846											27.8	1	33.4	47.8	50	50	44	128	49	50	50	45	125		
13346											33	1	39.7	55.6	60	60	51	128	56.9	60	60	52	125		
14246											41.7	2	50.2	68.8	70	70	63	128	70	70	70	64	125		
575-3-60	4.8	33	8	4.8	33	8	1.1	3.4	0.4	None	-	-	-	16.4	20	20	17	103	17.2	20	20	18	100		
										11758	17	1	16.4	24.8	25	25	23	103	25.8	30	30	24	100		
										13458	34	1	32.7	45.1	50	50	42	103	46.1	50	50	42	100		
12 (10)	208-3-60	16	110	25	16	110	25	5.8	14.9	1.1	None	-	-	-	56.7	60	70	61	323	58.9	60	70	63	333	
											11725	12	1	33.3	60.3	70	70	61	323	63	70	70	63	333	
											12525	18.6	1	51.6	83.1	90	90	76	323	85.9	90	90	79	333	
											13225	24	1	66.6	101.9	110	110	94	323	104.6	110	110	96	333	
											14225	31.8	2	88.3	129	150	150	119	323	131.8	150	150	121	333	
	230-3-60	16	110	25	16	110	25	5.2	15	1	None	-	-	-	56.2	60	70	60	322	58.2	60	70	62	327	
											11725	16	1	38.5	66.9	70	70	62	322	69.4	70	70	64	327	
											12525	24.8	1	59.7	93.4	100	100	86	322	95.9	100	100	88	327	
											13225	32	1	77	115	125	125	106	322	117.5	125	125	108	327	
											14225	42.4	2	102	146.3	150	150	135	322	148.8	150	150	137	327	
	460-3-60	7.8	52	12	7.8	52	12	2.9	7.5	0.5	None	-	-	-	28	30	35	30	159	29	30	35	31	161	
											11746	16.5	1	19.8	34.1	35	35	31	159	35.4	40	40	33	161	
											12846	27.8	1	33.4	51.1	60	60	47	159	52.4	60	60	48	161	
											13346	33	1	39.7	59	60	60	54	159	60.3	70	70	55	161	
											14246	41.7	2	50.2	72.1	80	80	66	159	73.4	80	80	68	161	
	575-3-60	5.7	38.9	9	5.7	38.9	9	2.2	5.6	0.4	None	-	-	-	20.6	25	25	22	124	21.4	25	25	23	126	
											11758	17	1	16.4	27.5	30	30	25	124	28.5	30	30	26	126	
											13458	34	1	32.7	47.9	50	50	44	124	48.9	50	50	45	126	
<b>With VFD</b>																									
A7 (6)	208-3-60	17.6	136	27				2.3	9.9	1.1	None	-	-	-	36.5	40	50	37	218	38.7	40	50	39	223	
											10725	4.9	1	13.6	36.5	40	50	37	218	38.7	40	50	39	223	
											11725	12	1	33.3	54	60	60	50	218	56.8	60	60	52	223	
											12525	18.6	1	51.6	76.9	80	80	71	218	79.6	80	80	73	223	
											None	-	-	-	36	40	50	36	227	38	40	50	39	231	
	230-3-60	17.6	136	27				2.3	9.4	1	10725	6.5	1	15.6	36	40	50	36	227	38	40	50	39	231	
											11725	16	1	38.5	59.9	60	60	55	227	62.4	70	70	57	231	
											12525	24.8	1	59.7	86.4	90	90	79	227	88.9	90	90	82	231	
											None	-	-	-	17.9	20	25	18	112	18.9	20	25	19	114	
											10746	6	1	7.2	17.9	20	25	14	112	18.9	20	25	15	114	
	460-3-60	8.5	66.1	13				1.3	4.7	0.5	11746	16.5	1	19.8	30.6	35	35	28	112	31.9	35	35	29	114	
											12646	25.5	1	30.7	44.3	45	45	41	112	45.5	50	50	42	114	
None											-	-	-	14.4	15	20	15	100	15.2	20	20	16	102		
575-3-60	6.3	55.3	10				1.1	4.3	0.4	11758	17	1	16.4	25.9	30	30	24	100	26.9	30	30	25	102		
										12658	25.7	1	24.7	36.3	40	40	33	100	37.3	40	40	34	102		

**ZYE04-12 High Static Indoor Blower - Without Powered Convenience Outlet (Continued)**

Size (Tons)	Nominal Unit Voltage	Compressor 1			Compressor 2			OD Fan Motors (each)	Supply Blower Motor	Pwr Exh Motor	Pwr Conv Outlet	Electric Heat Field Installed Kit 2EK045*				MCA <sup>1</sup> (Amps)	Min Fuse <sup>2</sup> / Breaker <sup>3</sup> Size (Amps)	Max Fuse <sup>2</sup> / Breaker <sup>3</sup> Size (Amps)	Min Disconnect Rating <sup>4</sup>		MCA <sup>1</sup> w/Pwr Exh (Amps)	Min Fuse <sup>2</sup> / Breaker <sup>3</sup> Size w/ Pwr Exh (Amps)	Max Fuse <sup>2</sup> / Breaker <sup>3</sup> Size w/ Pwr Exh (Amps)	Min Disconnect Rating <sup>4</sup> / Pwr Exh		
		RLA	LRA	MCC	RLA	LRA	MCC					Model	kW	Stages	Amps				FLA	LRA				FLA	LRA	
08 (7.5)	208-3-60	13.6	83.1	21	13.6	83.1	21	2.3	9.9	1.1		None	-	-	-	45.1	50	50	48	258	47.3	50	50	50	268	
												11725	12	1	33.3	54	60	60	50	258	56.8	60	60	52	268	
												12525	18.6	1	51.6	76.9	80	80	71	258	79.6	80	80	73	268	
												13225	24	1	66.6	95.6	100	100	88	258	98.4	100	100	91	268	
	230-3-60	13.6	83.1	21	13.6	83.1	21	2.3	9.4	1			None	-	-	-	44.6	45	50	47	267	46.6	50	60	50	261
													11725	16	1	38.5	59.9	60	60	55	267	62.4	70	70	57	261
													12525	24.8	1	59.7	86.4	90	90	79	267	88.9	90	90	82	261
													13225	32	1	77	108	110	110	99	267	110.5	125	125	102	261
	460-3-60	6.1	41	10	6.1	41	10	1.3	4.7	0.5			None	-	-	-	21	25	25	22	134	22	25	25	24	130
													11746	16.5	1	19.8	30.6	35	35	28	134	31.9	35	35	29	130
													12846	27.8	1	33.4	47.6	50	50	44	134	48.9	50	50	45	130
													13346	33	1	39.7	55.5	60	60	51	134	56.8	60	60	52	130
	575-3-60	4.2	33	7	4.2	33	7	1.1	4.3	0.4			None	-	-	-	16	20	20	17	115	16.8	20	20	18	113
													11758	17	1	16.4	25.9	30	30	24	115	26.9	30	30	25	113
													13458	34	1	32.7	46.3	50	50	43	115	47.3	50	50	43	113
09 (8.5)	208-3-60	13.7	83.1	21	13.7	83.1	21	2.3	9.9	1.1		None	-	-	-	45.3	50	50	48	258	47.5	50	60	51	268	
												11725	12	1	33.3	54	60	60	50	258	56.8	60	60	52	268	
												12525	18.6	1	51.6	76.9	80	80	71	258	79.6	80	80	73	268	
												13225	24	1	66.6	95.6	100	100	88	258	98.4	100	100	91	268	
	230-3-60	13.7	83.1	21	13.7	83.1	21	2.3	9.4	1			None	-	-	-	44.8	45	50	48	267	46.8	50	60	50	261
													11725	16	1	38.5	59.9	60	60	55	267	62.4	70	70	57	261
													12525	24.8	1	59.7	86.4	90	90	79	267	88.9	90	90	82	261
													13225	32	1	77	108	110	110	99	267	110.5	125	125	102	261
	460-3-60	6.2	41	10	6.2	41	10	1.3	4.7	0.5			None	-	-	-	21.3	25	25	23	134	22.3	25	25	24	130
													11746	16.5	1	19.8	30.6	35	35	28	134	31.9	35	35	29	130
													12846	27.8	1	33.4	47.6	50	50	44	134	48.9	50	50	45	130
													13346	33	1	39.7	55.5	60	60	51	134	56.8	60	60	52	130
	575-3-60	4.8	33	8	4.8	33	8	1.1	4.3	0.4			None	-	-	-	17.3	20	20	19	115	18.1	20	20	19	113
													11758	17	1	16.4	25.9	30	30	24	115	26.9	30	30	25	113
													13458	34	1	32.7	46.3	50	50	43	115	47.3	50	50	43	113
12 (10)	208-3-60	16	110	25	16	110	25	5.8	13.5	1.1		None	-	-	-	55.3	60	70	59	345	57.5	60	70	62	355	
												11725	12	1	33.3	58.5	60	70	59	345	61.3	70	70	62	355	
												12525	18.6	1	51.6	81.4	90	90	75	345	84.1	90	90	77	355	
												13225	24	1	66.6	100.1	110	110	92	345	102.9	110	110	95	355	
	230-3-60	16	110	25	16	110	25	5.2	13.4	1			None	-	-	-	54.6	60	70	58	341	56.6	60	70	60	346
													11725	16	1	38.5	64.9	70	70	60	341	67.4	70	70	62	346
													12525	24.8	1	59.7	91.4	100	100	84	341	93.9	100	100	86	346
													13225	32	1	77	113	125	125	104	341	115.5	125	125	106	346
	460-3-60	7.8	52	12	7.8	52	12	2.9	6.7	0.5			None	-	-	-	27.2	30	30	29	166	28.2	30	30	30	168
													11746	16.5	1	19.8	33.1	35	35	30	166	34.4	35	35	32	168
													12846	27.8	1	33.4	50.1	60	60	46	166	51.4	60	60	47	168
													13346	33	1	39.7	58	60	60	53	166	59.3	60	60	55	168
	575-3-60	5.7	38.9	9	5.7	38.9	9	2.2	5.4	0.4			None	-	-	-	20.4	25	25	22	129	21.2	25	25	23	131
													11758	17	1	16.4	27.3	30	30	25	129	28.3	30	30	26	131
													13458	34	1	32.7	47.6	50	50	44	129	48.6	50	50	45	131

1. Minimum Circuit Ampacity.
2. Dual Element, Time Delay Type.
3. HACR type per NEC.
4. Non-fused Disconnect, Verify on the unit nameplate that the disconnect is properly sized for the application. Units with field installed electric heat kits may exceed the factory installed disconnect amperage rating.

**ZYE04-12 High Static Indoor Blower - With Powered Convenience Outlet**

Size (Tons)	Nominal Unit Voltage	Compressor 1			Compressor 2			OD Fan Motors (each)	Supply Blower Motor	Pwr Exh Motor	Pwr Conv Outlet	Electric Heat Field Installed Kit 2EK045*			MCA <sup>1</sup> (Amps)	Min Fuse <sup>2</sup> / Breaker <sup>3</sup> Size (Amps)	Max Fuse <sup>2</sup> / Breaker <sup>3</sup> Size (Amps)	Min Discon-nect Rating <sup>4</sup>		MCA <sup>1</sup> w/Pwr Exh (Amps)	Min Fuse <sup>2</sup> / Breaker <sup>3</sup> Size w/ Pwr Exh (Amps)	Max Fuse <sup>2</sup> / Breaker <sup>3</sup> Size w/ Pwr Exh (Amps)	Min Discon-nect Rating <sup>4</sup> / Pwr Exh		
		RLA	LRA	MCC	RLA	LRA	MCC					Model	kW	Stages				Amps	FLA				LRA	FLA	LRA
04 (3)	208-3-60	10.4	73	16				1.4	5.2	1.1	8.6	None	-	-	-	23.9	25	30	24	103	25	25	35	26	105
												10625	4.9	1	13.6	28.9	30	30	27	103	30.3	35	35	28	105
												11125	7.9	1	21.9	39.3	40	40	36	103	40.6	45	45	37	105
												11625	12	1	33.3	53.5	60	60	49	103	54.9	60	60	50	105
	230-3-60	10.4	73	16				1.4	5.2	1	8.6	None	-	-	-	23.9	25	30	24	106	24.9	25	35	26	108
												10625	6.5	1	15.6	31.4	35	35	29	106	32.6	35	35	30	108
												11125	10.5	1	25.3	43.5	45	45	40	106	44.8	45	45	41	108
												11625	16	1	38.5	60	60	60	55	106	61.3	70	70	56	108
	460-3-60	5.8	38	9				0.8	2.6	0.5	8.6	None	-	-	-	12.9	15	15	13	55	13.4	15	15	14	56
												10646	6	1	7.2	14.9	15	15	14	55	15.6	20	20	14	56
												11146	11.5	1	13.8	23.2	25	25	21	55	23.8	25	25	22	56
												11446	14	1	16.8	26.9	30	30	25	55	27.6	30	30	25	56
575-3-60	3.8	36.5	6				0.6	2	0.4	8.6	None	-	-	-	9.1	15	15	9	50	9.5	15	15	10	51	
											11058	9.2	1	8.9	15.8	20	20	15	50	16.3	20	20	15	51	
											11458	13.8	1	13.3	21.3	25	25	20	50	21.8	25	25	20	51	
											None	-	-	-	30.3	35	40	31	139	31.4	35	45	32	142	
05 (4)	208-3-60	13.7	83.1	21			1.4	7.5	1.1	8.6	None	-	-	-	30.3	35	40	31	139	31.4	35	45	32	142	
											10625	4.9	1	13.6	31.8	35	40	31	139	33.1	35	45	32	142	
											11125	7.9	1	21.9	42.1	45	45	39	139	43.5	45	45	40	142	
											11625	12	1	33.3	56.4	60	60	52	139	57.8	60	60	53	142	
	230-3-60	13.7	83.1	21				1.4	7.5	1	8.6	None	-	-	-	30.3	35	40	31	146	31.3	35	45	32	148
												10625	6.5	1	15.6	34.3	35	40	32	146	35.5	40	45	33	148
												11125	10.5	1	25.3	46.4	50	50	43	146	47.6	50	50	44	148
												11625	16	1	38.5	62.9	70	70	58	146	64.1	70	70	59	148
	460-3-60	6.2	41	10				0.8	3.4	0.5	8.6	None	-	-	-	14.2	15	20	14	73	14.7	15	20	15	74
												10646	6	1	7.2	15.9	20	20	15	73	16.6	20	20	15	74
												11146	11.5	1	13.8	24.2	25	25	22	73	24.8	25	25	23	74
												11446	14	1	16.8	27.9	30	30	26	73	28.6	30	30	26	74
575-3-60	4.8	33	8				0.6	2.8	0.4	8.6	None	-	-	-	11.1	15	15	11	58	11.5	15	15	12	59	
											11058	9.2	1	8.9	16.8	20	20	15	58	17.3	20	20	16	59	
											11458	13.8	1	13.3	22.3	25	25	20	58	22.8	25	25	21	59	
											None	-	-	-	35.4	40	50	36	196	36.5	40	50	37	198	
06 (5)	208-3-60	15.9	110	25			2.3	8.9	1.1	8.6	None	-	-	-	35.4	40	50	36	196	36.5	40	50	37	198	
											10625	4.9	1	13.6	35.4	40	50	36	196	36.5	40	50	37	198	
											11125	7.9	1	21.9	43.9	45	50	40	196	45.3	50	50	42	198	
											11625	12	1	33.3	58.1	60	60	53	196	59.5	60	60	55	198	
	230-3-60	15.9	110	25				2.3	8.2	1	8.6	None	-	-	-	34.7	35	50	35	198	35.7	40	50	36	201
												10625	6.5	1	15.6	35.1	40	50	35	198	36.4	40	50	36	201
												11125	10.5	1	25.3	47.3	50	50	43	198	48.5	50	50	45	201
												11625	16	1	38.5	63.8	70	70	59	198	65	70	70	60	201
	460-3-60	7.1	52	11				1.3	4.1	0.5	8.6	None	-	-	-	16.5	20	20	17	92	17	20	20	17	93
												11146	6	1	7.2	16.8	20	20	15	92	17.4	20	20	16	93
												11146	11.5	1	13.8	25.1	30	30	23	92	25.7	30	30	24	93
												11446	14	1	16.8	28.8	30	30	27	92	29.4	30	30	27	93
575-3-60	5.1	39.5	8				1.1	3.2	0.4	8.6	None	-	-	-	12.4	15	15	13	70	12.8	15	15	13	71	
											11458	13.8	1	13.3	22.8	25	25	21	70	23.3	25	25	21	71	
											12358	23	1	22.1	33.8	35	35	31	70	34.3	35	35	32	71	
											None	-	-	-	35.4	40	50	36	196	36.5	40	50	37	198	

ZYE04-12 High Static Indoor Blower - With Powered Convenience Outlet (Continued)

Size (Tons)	Nominal Unit Voltage	Compressor 1			Compressor 2			OD Fan Motors (each)	Supply Blower Motor	Pwr Exh Motor	Pwr Conv Outlet	Electric Heat Field Installed Kit 2EK045*				MCA <sup>1</sup> (Amps)	Min Fuse <sup>2</sup> /Breaker <sup>3</sup> Size (Amps)	Max Fuse <sup>2</sup> /Breaker <sup>3</sup> Size (Amps)	Min Disconnect Rating <sup>4</sup>		MCA <sup>1</sup> w/Pwr Exh (Amps)	Min Fuse <sup>2</sup> /Breaker <sup>3</sup> Size w/ Pwr Exh (Amps)	Max Fuse <sup>2</sup> /Breaker <sup>3</sup> Size w/ Pwr Exh (Amps)	Min Disconnect Rating <sup>4</sup> /Pwr Exh	
		RLA	LRA	MCC	RLA	LRA	MCC					Model	kW	Stages	Amps				FLA	LRA				FLA	LRA
07 (6)	208-3-60	19	123	30				2.3	10.2	1.1	8.6	None	-	-	-	42.9	45	60	44	210	45.1	50	60	46	220
												10725	4.9	1	13.6	42.9	45	60	44	210	45.1	50	60	46	220
												11725	12	1	33.3	59.8	60	60	55	210	62.5	70	70	58	220
												12525	18.6	1	51.6	82.6	90	90	76	210	85.4	90	90	79	220
	230-3-60	19	123	30				2.3	10.2	1	8.6	None	-	-	-	42.9	45	60	44	216	44.9	45	60	46	211
												10725	6.5	1	15.6	42.9	45	60	44	216	44.9	45	60	46	211
												11725	16	1	38.5	66.3	70	70	61	216	68.8	70	70	63	211
												12525	24.8	1	59.7	92.8	100	100	85	216	95.3	100	100	88	211
	460-3-60	9.7	62	15				1.3	4.8	0.5	8.6	None	-	-	-	21.7	25	30	22	110	22.7	25	30	23	107
												10746	6	1	7.2	21.7	25	30	16	110	22.7	25	30	17	107
												11746	16.5	1	19.8	33.4	35	35	31	110	34.7	35	35	32	107
												12646	25.5	1	30.7	47.1	50	50	43	110	48.3	50	50	44	107
575-3-60	7.4	50	12				1.1	3.4	0.4	8.6	None	-	-	-	16.6	20	20	17	89	17.4	20	20	18	86	
											11758	17	1	16.4	26.9	30	30	25	89	27.9	30	30	26	86	
											12658	25.7	1	24.7	37.3	40	40	34	89	38.3	40	40	35	86	
A7 (6)	208-3-60	17.6	136	27				2.3	10.2	1.1	8.6	None	-	-	-	41.1	45	50	42	213	43.3	45	50	45	218
												10725	4.9	1	13.6	41.1	45	50	42	213	43.3	45	50	45	218
												11725	12	1	33.3	59.8	60	60	55	213	62.5	70	70	58	218
												12525	18.6	1	51.6	82.6	90	90	76	213	85.4	90	90	79	218
	230-3-60	17.6	136	27				2.3	10.2	1	8.6	None	-	-	-	41.1	45	50	42	219	43.1	45	60	45	224
												10725	6.5	1	15.6	41.1	45	50	42	219	43.1	45	60	45	224
												11725	16	1	38.5	66.3	70	70	61	219	68.8	70	70	63	224
												12525	24.8	1	59.7	92.8	100	100	85	219	95.3	100	100	88	224
	460-3-60	8.5	66.1	13				1.3	4.8	0.5	8.6	None	-	-	-	20.2	25	25	21	109	21.2	25	25	22	111
												10746	6	1	7.2	20.2	25	25	16	109	21.2	25	25	17	111
												11746	16.5	1	19.8	33.4	35	35	31	109	34.7	35	35	32	111
												12646	25.5	1	30.7	47.1	50	50	43	109	48.3	50	50	44	111
575-3-60	6.3	55.3	10				1.1	3.4	0.4	8.6	None	-	-	-	15.2	20	20	16	89	16	20	20	17	91	
											11758	17	1	16.4	26.9	30	30	25	89	27.9	30	30	26	91	
											12658	25.7	1	24.7	37.3	40	40	34	89	38.3	40	40	35	91	
08 (7.5)	208-3-60	13.6	83.1	21	13.6	83.1	21	2.3	10.2	1.1	8.6	None	-	-	-	49.7	50	60	53	253	51.9	60	60	56	263
												11725	12	1	33.3	59.8	60	60	55	253	62.5	70	70	58	263
												12525	18.6	1	51.6	82.6	90	90	76	253	85.4	90	90	79	263
												13225	24	1	66.6	101.4	110	110	93	253	104.1	110	110	96	263
	230-3-60	13.6	83.1	21	13.6	83.1	21	2.3	10.2	1	8.6	None	-	-	-	49.7	50	60	53	260	51.7	60	60	56	254
												11725	16	1	38.5	66.3	70	70	61	260	68.8	70	70	63	254
												12525	24.8	1	59.7	92.8	100	100	85	260	95.3	100	100	88	254
												13225	32	1	77	114.4	125	125	105	260	116.9	125	125	108	254
	460-3-60	6.1	41	10	6.1	41	10	1.3	4.8	0.5	8.6	None	-	-	-	23.3	25	25	25	130	24.3	25	25	26	127
												11746	16.5	1	19.8	33.4	35	35	31	130	34.7	35	35	32	127
												12846	27.8	1	33.4	50.4	60	60	46	130	51.7	60	60	48	127
												13346	33	1	39.7	58.3	60	60	54	130	59.6	60	60	55	127
575-3-60	4.2	33	7	4.2	33	7	1.1	3.4	0.4	8.6	None	-	-	-	16.8	20	20	18	105	17.6	20	20	19	102	
											11758	17	1	16.4	26.9	30	30	25	105	27.9	30	30	26	102	
											13458	34	1	32.7	47.3	50	50	43	105	48.3	50	50	44	102	

**ZYE04-12 High Static Indoor Blower - With Powered Convenience Outlet (Continued)**

Size (Tons)	Nominal Unit Voltage	Compressor 1			Compressor 2			OD Fan Motors (each)	Supply Blower Motor	Pwr Exh Motor	Pwr Conv Outlet	Electric Heat Field Installed Kit 2EK045*			MCA <sup>1</sup> (Amps)	Min Fuse <sup>2/</sup> Breaker <sup>3</sup> Size (Amps)	Max Fuse <sup>2/</sup> Breaker <sup>3</sup> Size (Amps)	Min Discon-nect Rating <sup>4</sup>		MCA <sup>1</sup> w/Pwr Exh (Amps)	Min Fuse <sup>2/</sup> Breaker <sup>3</sup> Size w/ Pwr Exh (Amps)	Max Fuse <sup>2/</sup> Breaker <sup>3</sup> Size w/ Pwr Exh (Amps)	Min Discon-nect Rating <sup>4</sup> w/ Pwr Exh		
		RLA	LRA	MCC	RLA	LRA	MCC					Model	kW	Stages				Amps	FLA				LRA	FLA	LRA
09 (8.5)	208-3-60	13.7	83.1	21	13.7	83.1	21	2.3	10.2	1.1	8.6	None	-	-	-	49.9	50	60	53	253	52.1	60	60	56	263
												11725	12	1	33.3	59.8	60	60	55	253	62.5	70	70	58	263
												12525	18.6	1	51.6	82.6	90	90	76	253	85.4	90	90	79	263
												13225	24	1	66.6	101.4	110	110	93	253	104.1	110	110	96	263
	230-3-60	13.7	83.1	21	13.7	83.1	21	2.3	10.2	1	8.6	None	-	-	-	49.9	50	60	53	260	51.9	60	60	56	254
												11725	16	1	38.5	66.3	70	70	61	260	68.8	70	70	63	254
												12525	24.8	1	59.7	92.8	100	100	85	260	95.3	100	100	88	254
												13225	32	1	77	114.4	125	125	105	260	116.9	125	125	108	254
	460-3-60	6.2	41	10	6.2	41	10	1.3	4.8	0.5	8.6	None	-	-	-	23.6	25	25	25	130	24.6	25	25	26	127
												11746	16.5	1	19.8	33.4	35	35	31	130	34.7	35	35	32	127
												12846	27.8	1	33.4	50.4	60	60	46	130	51.7	60	60	48	127
												13346	33	1	39.7	58.3	60	60	54	130	59.6	60	60	55	127
	575-3-60	4.8	33	8	4.8	33	8	1.1	3.4	0.4	8.6	None	-	-	-	18.1	20	20	19	105	18.9	20	20	20	102
												11758	17	1	16.4	26.9	30	30	25	105	27.9	30	30	26	102
												13458	34	1	32.7	47.3	50	50	43	105	48.3	50	50	44	102
												None	-	-	-	61	70	70	66	328	63.2	70	70	68	338
12 (10)	208-3-60	16	110	25	16	110	25	5.8	14.9	1.1	8.6	None	-	-	-	61	70	70	66	328	63.2	70	70	68	338
												11725	12	1	33.3	65.6	70	70	66	328	68.4	70	70	68	338
												12525	18.6	1	51.6	88.5	90	90	81	328	91.3	100	100	84	338
												13225	24	1	66.6	107.3	110	110	99	328	110	125	125	101	338
	230-3-60	16	110	25	16	110	25	5.2	15	1	8.6	None	-	-	-	60.5	70	70	65	326	62.5	70	70	67	331
												11725	16	1	38.5	72.3	80	80	66	326	74.8	80	80	69	331
												12525	24.8	1	59.7	98.8	100	100	91	326	101.3	110	110	93	331
												13225	32	1	77	120.4	125	125	111	326	122.9	125	125	113	331
	460-3-60	7.8	52	12	7.8	52	12	2.9	7.5	0.5	8.6	None	-	-	-	30.2	35	35	32	161	31.2	35	35	34	163
												11746	16.5	1	19.8	36.8	40	40	34	161	38.1	40	40	35	163
												12846	27.8	1	33.4	53.8	60	60	50	161	55.1	60	60	51	163
												13346	33	1	39.7	61.7	70	70	57	161	62.9	70	70	58	163
	575-3-60	5.7	38.9	9	5.7	38.9	9	2.2	5.6	0.4	8.6	None	-	-	-	22.3	25	25	24	126	23.1	25	25	25	128
												11758	17	1	16.4	29.7	30	30	27	126	30.7	35	35	28	128
												13458	34	1	32.7	50	50	50	46	126	51	60	60	47	128
												None	-	-	-	40.8	45	50	42	222	43	45	50	44	227
A7 (6)	208-3-60	17.6	136	27				2.3	9.9	1.1	8.6	10725	4.9	1	13.6	40.8	45	50	42	222	43	45	50	44	227
												11725	12	1	33.3	59.4	60	60	55	222	62.1	70	70	57	227
												12525	18.6	1	51.6	82.3	90	90	76	222	85	90	90	78	227
												None	-	-	-	40.3	45	50	41	231	42.3	45	50	44	236
	230-3-60	17.6	136	27				2.3	9.4	1	8.6	10725	6.5	1	15.6	40.3	45	50	41	231	42.3	45	50	44	236
												11725	16	1	38.5	65.3	70	70	60	231	67.8	70	70	62	236
												12525	24.8	1	59.7	91.8	100	100	84	231	94.3	100	100	87	236
												None	-	-	-	20.1	25	25	21	114	21.1	25	25	22	117
	460-3-60	8.5	66.1	13				1.3	4.7	0.5	8.6	10746	6	1	7.2	20.1	25	25	16	114	21.1	25	25	17	117
												11746	16.5	1	19.8	33.3	35	35	31	114	34.6	35	35	32	117
												12646	25.5	1	30.7	46.9	50	50	43	114	48.2	50	50	44	117
												None	-	-	-	16.1	20	20	17	102	16.9	20	20	18	104
	575-3-60	6.3	55.3	10				1.1	4.3	0.4	8.6	11758	17	1	16.4	28	30	30	26	102	29	30	30	27	104
												12658	25.7	1	24.7	38.4	40	40	35	102	39.4	40	40	36	104

**ZYE04-12 High Static Indoor Blower - With Powered Convenience Outlet (Continued)**

Size (Tons)	Nominal Unit Voltage	Compressor 1			Compressor 2			OD Fan Motors (each)	Supply Blower Motor	Pwr Exh Motor	Pwr Conv Outlet	Electric Heat Field Installed Kit 2EK045*				MCA <sup>1</sup> (Amps)	Min Fuse <sup>2</sup> / Breaker <sup>3</sup> Size (Amps)	Max Fuse <sup>2</sup> / Breaker <sup>3</sup> Size (Amps)	Min Discon- nect Rating <sup>4</sup>		MCA <sup>1</sup> w/Pwr Exh (Amps)	Min Fuse <sup>2</sup> / Breaker <sup>3</sup> Size w/ Pwr Exh (Amps)	Max Fuse <sup>2</sup> / Breaker <sup>3</sup> Size w/ Pwr Exh (Amps)	Min Discon- nect Rating <sup>4</sup> Pwr Exh	
		RLA	LRA	MCC	RLA	LRA	MCC					Model	kW	Stages	Amps				FLA	LRA				FLA	LRA
08 (7.5)	208-3-60	13.6	83.1	21	13.6	83.1	21	2.3	9.9	1.1	8.6	None	-	-	-	49.4	50	60	53	262	51.6	60	60	55	272
												11725	12	1	33.3	59.4	60	60	55	262	62.1	70	70	57	272
												12525	18.6	1	51.6	82.3	90	90	76	262	85	90	90	78	272
												13225	24	1	66.6	101	110	110	93	262	103.8	110	110	95	272
	230-3-60	13.6	83.1	21	13.6	83.1	21	2.3	9.4	1	8.6	None	-	-	-	48.9	50	60	52	271	50.9	60	60	55	266
												11725	16	1	38.5	65.3	70	70	60	271	67.8	70	70	62	266
												12525	24.8	1	59.7	91.8	100	100	84	271	94.3	100	100	87	266
												13225	32	1	77	113.4	125	125	104	271	115.9	125	125	107	266
	460-3-60	6.1	41	10	6.1	41	10	1.3	4.7	0.5	8.6	None	-	-	-	23.2	25	25	25	136	24.2	25	25	26	132
												11746	16.5	1	19.8	33.3	35	35	31	136	34.6	35	35	32	132
												12846	27.8	1	33.4	50.3	60	60	46	136	51.6	60	60	47	132
												13346	33	1	39.7	58.2	60	60	54	136	59.4	60	60	55	132
	575-3-60	4.2	33	7	4.2	33	7	1.1	4.3	0.4	8.6	None	-	-	-	17.7	20	20	19	117	18.5	20	20	20	114
												11758	17	1	16.4	28	30	30	26	117	29	30	30	27	114
												13458	34	1	32.7	48.4	50	50	45	117	49.4	50	50	45	114
												None	-	-	-	49.6	50	60	53	262	51.8	60	60	56	272
09 (8.5)	208-3-60	13.7	83.1	21	13.7	83.1	21	2.3	9.9	1.1	8.6	None	-	-	-	49.6	50	60	53	262	51.8	60	60	56	272
												11725	12	1	33.3	59.4	60	60	55	262	62.1	70	70	57	272
												12525	18.6	1	51.6	82.3	90	90	76	262	85	90	90	78	272
												13225	24	1	66.6	101	110	110	93	262	103.8	110	110	95	272
	230-3-60	13.7	83.1	21	13.7	83.1	21	2.3	9.4	1	8.6	None	-	-	-	49.1	50	60	53	271	51.1	60	60	55	266
												11725	16	1	38.5	65.3	70	70	60	271	67.8	70	70	62	266
												12525	24.8	1	59.7	91.8	100	100	84	271	94.3	100	100	87	266
												13225	32	1	77	113.4	125	125	104	271	115.9	125	125	107	266
	460-3-60	6.2	41	10	6.2	41	10	1.3	4.7	0.5	8.6	None	-	-	-	23.5	25	25	25	136	24.5	25	25	26	132
												11746	16.5	1	19.8	33.3	35	35	31	136	34.6	35	35	32	132
												12846	27.8	1	33.4	50.3	60	60	46	136	51.6	60	60	47	132
												13346	33	1	39.7	58.2	60	60	54	136	59.4	60	60	55	132
	575-3-60	4.8	33	8	4.8	33	8	1.1	4.3	0.4	8.6	None	-	-	-	19	20	20	20	117	19.8	20	20	21	114
												11758	17	1	16.4	28	30	30	26	117	29	30	30	27	114
												13458	34	1	32.7	48.4	50	50	45	117	49.4	50	50	45	114
												None	-	-	-	59.6	60	70	64	349	61.8	70	70	66	359
12 (10)	208-3-60	16	110	25	16	110	25	5.8	13.5	1.1	8.6	None	-	-	-	59.6	60	70	64	349	61.8	70	70	66	359
												11725	12	1	33.3	63.9	70	70	64	349	66.6	70	70	66	359
												12525	18.6	1	51.6	86.8	90	90	80	349	89.5	90	90	82	359
												13225	24	1	66.6	105.5	110	110	97	349	108.3	110	110	100	359
	230-3-60	16	110	25	16	110	25	5.2	13.4	1	8.6	None	-	-	-	58.9	60	70	63	345	60.9	70	70	65	350
												11725	16	1	38.5	70.3	80	80	65	345	72.8	80	80	67	350
												12525	24.8	1	59.7	96.8	100	100	89	345	99.3	100	100	91	350
												13225	32	1	77	118.4	125	125	109	345	120.9	125	125	111	350
	460-3-60	7.8	52	12	7.8	52	12	2.9	6.7	0.5	8.6	None	-	-	-	29.4	30	35	32	168	30.4	35	35	33	170
												11746	16.5	1	19.8	35.8	40	40	33	168	37.1	40	40	34	170
												12846	27.8	1	33.4	52.8	60	60	49	168	54.1	60	60	50	170
												13346	33	1	39.7	60.7	70	70	56	168	61.9	70	70	57	170
	575-3-60	5.7	38.9	9	5.7	38.9	9	2.2	5.4	0.4	8.6	None	-	-	-	22.1	25	25	24	131	22.9	25	25	25	133
												11758	17	1	16.4	29.4	30	30	27	131	30.4	35	35	28	133
												13458	34	1	32.7	49.8	50	50	46	131	50.8	60	60	47	133
												None	-	-	-	59.6	60	70	64	349	61.8	70	70	66	359

1. Minimum Circuit Ampacity.
2. Dual Element, Time Delay Type.
3. HACR type per NEC.
4. Non-fused Disconnect, Verify on the unit nameplate that the disconnect is properly sized for the application. Units with field installed electric heat kits may exceed the factory installed disconnect amperage rating.



Table 10: Physical Data

## ZY04 Physical Data

Component	Models					
	ZYG04	ZYE04				
Nominal Tonnage	3					
AHRI COOLING PERFORMANCE	Gross Capacity @ AHRI A point (Btu)	40700				40700
	AHRI net capacity (Btu)	36000				36000
	EER	12				12
	SEER	15				15
	IEER	-				-
	IEER IntelliSpeed	-				-
	Nominal CFM	1200				1200
	System power (KW)	2.60				2.60
	Refrigerant type	R-410A				R-410A
	Refrigerant charge (lb-oz)					
	System 1	4-10				4-10
System 2	-				-	
AHRI HEATING PERFORMANCE SINGLE PHASE	Heating Option	L	D	M	E	-
	Heating model	Low (Low-NOx)	Low	Med (Low-NOx)	Med	-
	1st. Stage Heat input (K Btu)	-	-	-	-	-
	2nd. Stage Heat input (K Btu)	56	70	90	112	-
	1st. Stage Heat output (K Btu)	-	-	-	-	-
	2nd. Stage Heat output (K Btu)	45	56	72	90	-
	AFUE %	81	81	81	81	-
	No. burners	2	2	3	3	-
	No. stages	1	1	1	1	-
	Temperature Rise Range (°F)	10-40	20-50	35-65	50-80	-
	Gas Limit Setting (°F)	150	150	140	140	-
Gas piping connection (in.)	1/2	1/2	1/2	1/2	-	
AHRI HEATING PERFORMANCE THREE PHASE	Heating Option	L	D	M	E	-
	Heating model	Low (Low-NOx)	Low	Med (Low-NOx)	Med	-
	1st. Stage Heat input (K Btu)	-	49	-	82	-
	2nd. Stage Heat input (K Btu)	56	70	90	112	-
	1st. Stage Heat output (K Btu)	-	39	-	66	-
	2nd. Stage Heat output (K Btu)	45	56	72	90	-
	Steady state efficiency (%)	80	80	80	80	-
	No. burners	2	2	3	3	-
	No. stages	1	2	1	2	-
	Temperature Rise Range (°F)	28-46	35-58	44-74	55-78	-
	Gas Limit Setting (°F)	150	150	140	140	-
Gas piping connection (in.)	1/2	1/2	1/2	1/2	-	
DIMENSIONS (inches)	Length	74.1				74.1
	Width	48.9				48.9
	Height	32.5				32.5
OPERATING WT. (lbs.)	527				481	
COMPRESSORS	Type	Scroll				Scroll
	Quantity	1				1
	Unit Capacity Steps (%)	100				100
CONDENSER COIL DATA	Face area (Sq. Ft.)	16.3				16.3
	Rows	1				1
	Fins per inch	23				23
	Tube diameter (in./MM)	.63/16				.63/16
	Circuitry Type	2-pass Microchannel				2-pass Microchannel

**ZY04 Physical Data (Continued)**

Component	Models				
	ZYG04		ZYE04		
Nominal Tonnage	3		3		
<b>EVAPORATOR COIL DATA</b>	Face area (Sq. Ft.)	5.5		5.5	
	Rows	3		3	
	Fins per inch	15		15	
	Tube diameter	0.375		0.375	
	Circuitry Type	Intertwined		Intertwined	
	Refrigerant control	TXV		TXV	
<b>CONDENSER FAN DATA</b>	Quantity of fans	1		1	
	Fan diameter (Inch)	22		22	
	Type	Prop		Prop	
	Drive type	Direct		Direct	
	Quantity of motors	1		1	
	Motor HP each	1/4		1/4	
	No. speeds	1		1	
	RPM	1100		1100	
Nominal total CFM	3800		3800		
<b>EVAP FAN DATA DIRECT DRIVE</b>	Airflow Option	A		A	
	Quantity	1		1	
	Fan Size (Inch)	10 x 10		10 x 10	
	Type	Centrifugal		Centrifugal	
	Motor HP	3/4		3/4	
	RPM	1050		1050	
<b>EVAP FAN DATA BELT DRIVE</b>	Airflow Option	B	C	B	C
	Quantity	1	1	1	1
	Fan Size (Inch)	10 x 10	10 x 10	10 x 10	10 x 10
	Type	Centrifugal		Centrifugal	
	Motor Sheave	1VL34	1VL44	1VL34	1VL44
	Blower Sheave	AK46	AK46	AK46	AK46
	Belt	A39	A40	A39	A40
	Motor Hp, 1 Phase	1.5	-	1.5	-
	Motor Max Bhp, 3 Phase	2.4	2.4	2.4	2.4
	RPM	1725	1725	1725	1725
	Frame size	56Y	56Y	56Y	56Y
<b>FILTERS</b>	Quantity - Size	2 - (16 x 25 x 2) <sup>1</sup>		2 - (16 x 25 x 2) <sup>1</sup>	

1. 2 in. Throwaway, Standard, MERV 4 (Minimum Efficiency Reporting Value).

## ZY05 Physical Data

Component	Models							
	ZYG05				ZYE05			
Nominal Tonnage	4				4			
<b>AHRI COOLING PERFORMANCE</b>	Gross Capacity @ AHRI A point (Btu)	54800				54800		
	AHRI net capacity (Btu)	49000				49000		
	EER	12				12		
	SEER	15.4				15.4		
	IEER	-				-		
	IEER IntelliSpeed	-				-		
	Nominal CFM	1600				1600		
	System power (KW)	3.50				3.50		
	Refrigerant type	R-410A				R-410A		
	Refrigerant charge (lb-oz)							
	System 1	6-8				6-8		
	System 2	-				-		
<b>AHRI HEATING PERFORMANCE SINGLE PHASE</b>	Heating Options	L	D	M	E	N	F	-
	Heating model	Low (Low-NOx)	Low	Med (Low-NOx)	Med	High, (Low-NOx)	High	-
	1st. Stage Heat input (K Btu)	-	-	-	-	-	-	-
	2nd. Stage Heat input (K Btu)	56	70	90	112	116	142	-
	1st. Stage Heat output (K Btu)	-	-	-	-	-	-	-
	2nd. Stage Heat output (K Btu)	45	56	72	90	93	114	-
	AFUE %	81	81	81	81	81	81	-
	No. burners	2	2	3	3	3	3	-
	No. stages	1	1	1	1	1	1	-
	Temperature Rise Range (°F)	05-35	15-45	25-55	40-70	35-65	45-75	-
	Gas Limit Setting (°F)	150	150	140	140	150	145	-
	Gas piping connection (in.)	1/2	1/2	1/2	1/2	1/2	1/2	-
<b>AHRI HEATING PERFORMANCE THREE PHASE</b>	Heating Options	L	D	M	E	N	F	-
	Heating model	Low (Low-NOx)	Low	Med (Low-NOx)	Med	High, (Low-NOx)	High	-
	1st. Stage Heat input (K Btu)	-	49	-	82	-	100	-
	2nd. Stage Heat input (K Btu)	56	70	90	112	118	145	-
	1st. Stage Heat output (K Btu)	-	39	-	66	-	80	-
	2nd. Stage Heat output (K Btu)	45	56	72	90	94	116	-
	Steady state efficiency (%)	80	80	80	80	80	80	-
	No. burners	2	2	3	3	3	3	-
	No. stages	1	2	1	2	1	2	-
	Temperature Rise Range (°F)	21-35	26-43	33-56	41-69	44-73	49-77	-
	Gas Limit Setting (°F)	150	150	140	140	150	145	-
	Gas piping connection (in.)	1/2	1/2	1/2	1/2	1/2	1/2	-
<b>DIMENSIONS (inches)</b>	Length	74.1				74.1		
	Width	48.9				48.9		
	Height	40.6				40.6		
<b>OPERATING WT. (lbs.)</b>	618				564			
<b>COMPRESSORS</b>	Type	Scroll				Scroll		
	Quantity	1				1		
	Unit Capacity Steps (%)	100				100		
<b>CONDENSER COIL DATA</b>	Face area (Sq. Ft.)	21.1				21.1		
	Rows	1				1		
	Fins per inch	23				23		
	Tube diameter (in./MM)	.79/20				.79/20		
	Circuitry Type	2-pass Microchannel				2-pass Microchannel		

**ZY05 Physical Data (Continued)**

Component	Models				
	ZYG05		ZYE05		
Nominal Tonnage	4		4		
<b>EVAPORATOR COIL DATA</b>	Face area (Sq. Ft.)	7.3		7.3	
	Rows	3		3	
	Fins per inch	15		15	
	Tube diameter	0.375		0.375	
	Circuitry Type	Intertwined		Intertwined	
	Refrigerant control	TXV		TXV	
<b>CONDENSER FAN DATA</b>	Quantity of fans	1		1	
	Fan diameter (Inch)	22		22	
	Type	Prop		Prop	
	Drive type	Direct		Direct	
	Quantity of motors	1		1	
	Motor HP each	1/4		1/4	
	No. speeds	1		1	
	RPM	1100		1100	
	Nominal total CFM	4000		4000	
<b>EVAP FAN DATA DIRECT DRIVE</b>	Airflow Option	A		A	
	Quantity	1		1	
	Fan Size (Inch)	10 x 10		10 x 10	
	Type	Centrifugal		Centrifugal	
	Motor HP	1		1	
	RPM	1050		1050	
<b>EVAP FAN DATA BELT DRIVE</b>	Airflow Option	B	C	B	C
	Quantity	1	1	1	1
	Fan Size (Inch)	10 x 10	10 x 10	10 x 10	10 x 10
	Type	Centrifugal		Centrifugal	
	Motor Sheave	1VL34	1VL44	1VL44	1VL44
	Blower Sheave	AK46	AK46	AK46	AK46
	Belt	A39	A40	A39	A40
	Motor Hp, 1 Phase	1.5	-	1.5	-
	Motor Max Bhp, 3 Phase	2.4	2.9	2.4	2.9
	RPM	1725	1725	1725	1725
	Frame size	56Y	56Y	56Y	56Y
<b>FILTERS</b>	Quantity - Size	4 - (16 x 16 x 2) <sup>1</sup>		4 - (16 x 16 x 2) <sup>1</sup>	

1. 2 in. Throwaway, Standard, MERV 4 (Minimum Efficiency Reporting Value).

## ZY06 Physical Data

Component	Models							
	ZYG06				ZYE06			
Nominal Tonnage	5				5			
AHRI COOLING PERFORMANCE	Gross Capacity @ AHRI A point (Btu)	60000				60000		
	AHRI net capacity (Btu)	58000				58000		
	EER	12				12		
	SEER	15.2				15.2		
	IEER	-				-		
	IEER IntelliSpeed	-				-		
	Nominal CFM	1600				1600		
	System power (KW)	4.40				4.40		
	Refrigerant type	R-410A				R-410A		
	Refrigerant charge (lb-oz)							
	System 1	7-10				7-10		
System 2	-				-			
AHRI HEATING PERFORMANCE SINGLE PHASE	Heating Options	L	D	M	E	N	F	-
	Heating model	Low (Low-NOx)	Low	Med (Low-NOx)	Med	High, (Low-NOx)	High	-
	1st. Stage Heat input (K Btu)	-	-	-	-	-	-	-
	2nd. Stage Heat input (K Btu)	56	70	90	112	116	142	-
	1st. Stage Heat output (K Btu)	-	-	-	-	-	-	-
	2nd. Stage Heat output (K Btu)	45	56	72	90	93	114	-
	AFUE %	81	81	81	81	81	81	-
	No. burners	2	2	3	3	3	3	-
	No. stages	1	1	1	1	1	1	-
	Temperature Rise Range (°F)	05-35	10-40	15-45	30-60	30-60	40-70	-
	Gas Limit Setting (°F)	150	150	140	140	145	140	-
Gas piping connection (in.)	1/2	1/2	1/2	1/2	1/2	1/2	-	
AHRI HEATING PERFORMANCE THREE PHASE	Heating Options	L	D	M	E	N	F	-
	Heating model	Low (Low-NOx)	Low	Med (Low-NOx)	Med	High, (Low-NOx)	High	-
	1st. Stage Heat input (K Btu)	-	49	-	82	-	100	-
	2nd. Stage Heat input (K Btu)	56	70	90	112	118	145	-
	1st. Stage Heat output (K Btu)	-	39	-	66	-	80	-
	2nd. Stage Heat output (K Btu)	45	56	72	90	94	116	-
	Steady state efficiency (%)	80	80	80	80	80	80	-
	No. burners	2	2	3	3	3	3	-
	No. stages	1	2	1	2	1	2	-
	Temperature Rise Range (°F)	17-28	21-35	27-44	33-55	35-58	43-72	-
	Gas Limit Setting (°F)	150	150	140	140	145	140	-
Gas piping connection (in.)	1/2	1/2	1/2	1/2	1/2	1/2	-	
DIMENSIONS (inches)	Length	74.1				74.1		
	Width	48.9				48.9		
	Height	40.6				40.6		
OPERATING WT. (lbs.)	636				582			
COMPRESSORS	Type	Scroll				Scroll		
	Quantity	1				1		
	Unit Capacity Steps (%)	100				100		
CONDENSER COIL DATA	Face area (Sq. Ft.)	21.1				21.1		
	Rows	1				1		
	Fins per inch	23				23		
	Tube diameter (in./MM)	.79/20				.79/20		
	Circuitry Type	2-pass Microchannel				2-pass Microchannel		

**ZY06 Physical Data (Continued)**

Component		Models			
		ZYG06		ZYE06	
Nominal Tonnage		5		5	
<b>EVAPORATOR COIL DATA</b>	Face area (Sq. Ft.)	7.3		7.3	
	Rows	4		4	
	Fins per inch	15		15	
	Tube diameter	0.375		0.375	
	Circuitry Type	Intertwined		Intertwined	
	Refrigerant control	TXV		TXV	
<b>CONDENSER FAN DATA</b>	Quantity of fans	1		1	
	Fan diameter (Inch)	22		22	
	Type	Prop		Prop	
	Drive type	Direct		Direct	
	Quantity of motors	1		1	
	Motor HP each	1/2		1/2	
	No. speeds	1		1	
	RPM	1085		1085	
	Nominal total CFM	4600		4600	
<b>EVAP FAN DATA DIRECT DRIVE</b>	Airflow Option	A		A	
	Quantity	1		1	
	Fan Size (Inch)	11 x 10		11 x 10	
	Type	Centrifugal		Centrifugal	
	Motor HP	1		1	
	RPM	1050		1050	
<b>EVAP FAN DATA BELT DRIVE</b>	Airflow Option	B	C	B	C
	Quantity	1	1	1	1
	Fan Size (Inch)	11 x 10	11 x 10	11 x 10	11 x 10
	Type	Centrifugal		Centrifugal	
	Motor Sheave	1VL34	1VL44	1VL34	1VL44
	Blower Sheave	AK46	AK46	AK46	AK46
	Belt	A37	A39	A37	A39
	Motor Hp, 1 Phase	1.5	-	1.5	-
	Motor Max Bhp, 3 Phase	2.4	2.9	2.4	2.9
	RPM	1750	1750	1750	1750
	Frame size	56HZ	56Z	56HZ	56Z
<b>FILTERS</b>	Quantity - Size	4 - (16 x 16 x 2) <sup>1</sup>		4 - (16 x 16 x 2) <sup>1</sup>	

1. 2 in. Throwaway, Standard, MERV 4 (Minimum Efficiency Reporting Value).

## ZY07 Physical Data

Component	Models				
	ZYG07		ZYE07		
Nominal Tonnage	6		6		
AHRI COOLING PERFORMANCE	Gross Capacity @ AHRI A point (Btu)	81200		81200	
	AHRI net capacity (Btu)	72000		72000	
	EER	12		12.2	
	SEER	-		-	
	IEER	12.7		12.9	
	IEER IntelliSpeed	-		-	
	Nominal CFM	2400		2400	
	System power (KW)	5		5	
	Refrigerant type	R-410A		R-410A	
	Refrigerant charge (lb-oz)				
	System 1	8-8		8-8	
System 2	-		-		
AHRI HEATING PERFORMANCE	Heating Option	D	E	F	-
	Heating model	Low	Med	High	-
	1st. Stage Heat input (K Btu)	57	90	110	-
	2nd. Stage Heat input (K Btu)	72	125	150	-
	1st. Stage Heat output (K Btu)	46	72	88	-
	2nd. Stage Heat output (K Btu)	58	100	120	-
	AFUE %				-
	Steady state efficiency (%)	80	80	80	-
	No. burners	2	3	3	-
	No. stages	2	2	2	-
	Temperature Rise Range (°F)	18-30	31-51	37-62	-
	Gas Limit Setting (°F)	140	140	160	-
Gas piping connection (in.)	1/2	3/4	3/4	-	
DIMENSIONS (inches)	Length	87.2		87.2	
	Width	61.7		61.7	
	Height	40.6		40.6	
OPERATING WT. (lbs.)	804		734		
COMPRESSORS	Type	Scroll		Scroll	
	Quantity	1		1	
	Unit Capacity Steps (%)	100		100	
CONDENSER COIL DATA	Face area (Sq. Ft.)	21.1		21.1	
	Rows	1		1	
	Fins per inch	23		23	
	Tube diameter (in./MM)	1/25		1/25	
	Circuitry Type	2-pass Microchannel		2-pass Microchannel	
EVAPORATOR COIL DATA	Face area (Sq. Ft.)	8.9		8.9	
	Rows	3		3	
	Fins per inch	15		15	
	Tube diameter	0.375		0.375	
	Circuitry Type	Intertwined		Intertwined	
	Refrigerant control	TXV		TXV	
CONDENSER FAN DATA	Quantity of fans	2		2	
	Fan diameter (Inch)	22		22	
	Type	Prop		Prop	
	Drive type	Direct		Direct	
	Quantity of motors	2		2	
	Motor HP each	1/2		1/2	
	No. speeds	1		1	
	RPM	1085		1085	
Nominal total CFM	7600		7600		

**ZY07 Physical Data (Continued)**

Component		Models					
		ZYG07			ZYE07		
Nominal Tonnage		6			6		
<b>EVAP FAN DATA BELT DRIVE</b>	Airflow Option	A	B	C	A	B	C
	Quantity	1	1	1	1	1	1
	Fan Size (Inch)	15 x 15	15 x 15	15 x 15	15 x 15	15 x 15	15 x 15
	Type	Centrifugal			Centrifugal		
	Motor Sheave	1VL34	1VL44	1VP50	1VL34	1VL44	1VP50
	Blower Sheave	AK74	AK74	AK74	AK74	AK74	AK74
	Belt	A47	A48	A48	A47	A48	A48
	Motor Max Bhp, 3 Phase	2.4	2.9	3.7	2.4	2.9	3.7
	RPM	1725	1725	1725	1725	1725	1725
	Frame size	56Y	56Y	56HZ	56Y	56Y	56HZ
<b>FILTERS</b>	Quantity - Size	4 - (16 x 20 x 2) <sup>1</sup>			4 - (16 x 20 x 2) <sup>1</sup>		

1. 2 in. Throwaway, Standard, MERV 4 (Minimum Efficiency Reporting Value).



## ZYA7 Physical Data

Component	Models				
	ZYGA7		ZYEA7		
Nominal Tonnage	6		6		
<b>AHRI COOLING PERFORMANCE</b>	Gross Capacity @ AHRI A point (Btu)	73000		73000	
	AHRI net capacity (Btu)	71000		71000	
	EER	12		12	
	SEER	-		-	
	CV IEER	14.6		14.6	
	IEER IntelliSpeed	16		16	
	Nominal CFM	2350		2350	
	System power (KW)	5.87		5.89	
	Refrigerant type	R-410A		R-410A	
	Refrigerant charge (lb-oz)				
	System 1	7-11		7-11	
System 2	-		-		
<b>AHRI HEATING PERFORMANCE<sup>1</sup></b>	Heating Option	D	E	F	-
	Heating model	Low	Med	High	-
	1st. Stage Heat input (K Btu)	57	90	110	-
	2nd. Stage Heat input (K Btu)	72	125	150	-
	1st. Stage Heat output (K Btu)	46	72	88	-
	2nd. Stage Heat output (K Btu)	58	100	120	-
	AFUE %				-
	Steady state efficiency (%)	80	80	80	-
	No. burners	2	3	3	-
	No. stages	2	2	2	-
	Temperature Rise Range (°F)	18-30	31-51	37-62	-
Gas Limit Setting (°F)	140	140	160	-	
Gas piping connection (in.)	1/2	3/4	3/4	-	
<b>DIMENSIONS (inches)</b>	Length	87.2		87.2	
	Width	61.7		61.7	
	Height	40.6		40.6	
<b>OPERATING WT. (lbs.)</b>	899		829		
<b>COMPRESSORS</b>	Type	Scroll		Scroll	
	Quantity	1		1	
	Unit Capacity Steps (%)	67/100		67/100	
<b>CONDENSER COIL DATA</b>	Face area (Sq. Ft.)	21.1		21.1	
	Rows	1		1	
	Fins per inch	23		23	
	Tube diameter (in./MM)	1/25		1/25	
	Circuitry Type	2-pass Microchannel		2-pass Microchannel	
<b>EVAPORATOR COIL DATA</b>	Face area (Sq. Ft.)	8.9		8.9	
	Rows	3		3	
	Fins per inch	15		15	
	Tube diameter	0.375		0.375	
	Circuitry Type	Intertwined		Intertwined	
<b>CONDENSER FAN DATA</b>	Refrigerant control	TXV		TXV	
	Quantity of fans	2		2	
	Fan diameter (Inch)	22		22	
	Type	Prop		Prop	
	Drive type	Direct		Direct	
	Quantity of motors	2		2	
	Motor HP each	1/2		1/2	
	No. speeds	1		1	
	RPM	1085		1085	
	Nominal total CFM	7600		7600	

**ZYA7 Physical Data (Continued)**

Component	Models						
	ZYGA7			ZYEA7			
Nominal Tonnage	6			6			
<b>EVAP FAN DATA BELT DRIVE</b>	Airflow Option	A	B	C	A	B	C
	Quantity	1	1	1	1	1	1
	Fan Size (Inch)	15 x 15	15 x 15	15 x 15	15 x 15	15 x 15	15 x 15
	Type	Centrifugal			Centrifugal		
	Motor Sheave	1VL34	1VL44	1VP50	1VL34	1VL44	1VP50
	Blower Sheave	AK74	AK74	AK74	AK74	AK74	AK74
	Belt	A47	A48	A48	A47	A48	A48
	Motor Max Bhp, 3 Phase	2.4	2.9	3.7	2.4	2.9	3.7
	RPM	1725	1725	1725	1725	1725	1725
	Frame size	56Y	56Y	56HZ	56Y	56Y	56HZ
<b>FILTERS</b>	Quantity - Size	4 - (16 x 20 x 2) <sup>2</sup>			4 - (16 x 20 x 2) <sup>1</sup>		

1. 1st Stage 60% of 2nd Stage.
2. 2 in. Throwaway, Standard, MERV 4 (Minimum Efficiency Reporting Value).

## ZY08 Physical Data

Component		Model			
		ZYG08	ZYE08		
Nominal Tonnage		7.5	7.5		
AHRI COOLING PERFORMANCE	Gross Capacity @ AHRI A point (Btu)	97300	97300		
	AHRI net capacity (Btu)	89000	89000		
	EER	12	12.2		
	SEER	-	-		
	IEER	12.7	12.9		
	IEER IntelliSpeed	14.0	14.1		
	Nominal CFM	2900	2900		
	System power (KW)	6.6	6.6		
	Refrigerant type	R-410A	R-410A		
	Refrigerant charge (lb-oz)				
	System 1	6-0	6-0		
System 2	6-2	6-2			
AHRI HEATING PERFORMANCE	Heating Options	D	E	F	-
	Heating model	Low	Med	High	-
	1st. Stage Heat input (K Btu)	90	125	176	-
	2nd. Stage Heat input (K Btu)	125	180	220	-
	1st. Stage Heat output (K Btu)	72	100	141	-
	2nd. Stage Heat output (K Btu)	100	144	176	-
	AFUE %				-
	Steady state efficiency (%)	80	80	80	-
	No. burners	3	4	5	-
	No. stages	2	2	2	-
	Temperature Rise Range (°F)	25-41	36-59	43-72	-
	Gas Limit Setting (°F)	140	150	140	-
Gas piping connection (in.)	3/4	3/4	3/4	-	
DIMENSIONS (inches)	Length	87.2		87.2	
	Width	61.7		61.7	
	Height	48.6		48.6	
OPERATING WT. (lbs.)	980		878		
COMPRESSORS	Type	Scroll		Scroll	
	Quantity	2		2	
	Unit Capacity Steps (%)	50/100		50/100	
CONDENSER COIL DATA	Face area (Sq. Ft.)	25.5		25.5	
	Rows	1		1	
	Fins per inch	23		23	
	Tube diameter (in./MM)	1/25		1/25	
	Circuitry Type	2-pass Microchannel		2-pass Microchannel	
EVAPORATOR COIL DATA	Face area (Sq. Ft.)	11.1		11.1	
	Rows	4		4	
	Fins per inch	15		15	
	Tube diameter	0.375		0.375	
	Circuitry Type	Intertwined		Intertwined	
	Refrigerant control	TXV		TXV	
CONDENSER FAN DATA	Quantity of fans	2		2	
	Fan diameter (Inch)	22		22	
	Type	Prop		Prop	
	Drive type	Direct		Direct	
	Quantity of motors	2		2	
	Motor HP each	1/2		1/2	
	No. speeds	1		1	
	RPM	1085		1085	
	Nominal total CFM	8600		8600	

**ZY08 Physical Data (Continued)**

Component		Model					
		ZYG08			ZYE08		
Nominal Tonnage		7.5			7.5		
<b>EVAP FAN DATA BELT DRIVE</b>	Airflow Option	A	B	C	A	B	C
	Quantity	1	1	1	1	1	1
	Fan Size (Inch)	15 x 15	15 x 15	15 x 15	15 x 15	15 x 15	15 x 15
	Type	Centrifugal			Centrifugal		
	Motor Sheave	1VL34	1VL44	1VP50	1VL34	1VL44	1VP50
	Blower Sheave	AK74	AK74	AK74	AK74	AK74	AK74
	Belt	A47	A48	A50	A47	A48	A50
	Motor Max Bhp, 3 Phase	2.4	2.4	3.7	2.4	2.4	3.7
	RPM	1725	1725	1725	1725	1725	1725
	Frame size	56Y	56Y	56HZ	56Y	56Y	56HZ
<b>FILTERS</b>	Quantity - Size	4 - (20 x 20 x 2) <sup>1</sup>			4 - (20 x 20 x 2) <sup>1</sup>		

1. 2 in. Throwaway, Standard, MERV 4 (Minimum Efficiency Reporting Value).

## ZY09 Physical Data

Component	Model				
	ZYG09		ZYE09		
<b>Nominal Tonnage</b>	<b>8.5</b>		<b>8.5</b>		
<b>AHRI COOLING PERFORMANCE</b>	Gross Capacity @ AHRI A point (Btu)	109500		109500	
	AHRI net capacity (Btu)	98000		98000	
	EER	12		12.2	
	SEER	-		-	
	IEER	12.7		12.9	
	IEER IntelliSpeed	14.6		14.8	
	Nominal CFM	3300		3300	
	System power (KW)	7.30		7.30	
	Refrigerant type	R-410A		R-410A	
	Refrigerant charge (lb-oz)				
	System 1	6-8		6-8	
System 2	6-0		6-0		
<b>AHRI HEATING PERFORMANCE</b>	Heating Options	D	E	F	-
	Heating model	Low	Med	High	-
	1st. Stage Heat input (K Btu)	90	125	176	-
	2nd. Stage Heat input (K Btu)	125	180	220	-
	1st. Stage Heat output (K Btu)	72	100	141	-
	2nd. Stage Heat output (K Btu)	100	144	176	-
	AFUE %				-
	Steady state efficiency (%)	80	80	80	-
	No. burners	3	4	5	-
	No. stages	2	2	2	-
	Temperature Rise Range (°F)	22-36	31-52	38-64	-
	Gas Limit Setting (°F)	140	150	140	-
Gas piping connection (in.)	3/4	3/4	3/4	-	
<b>DIMENSIONS (inches)</b>	Length	87.2		87.2	
	Width	61.7		61.7	
	Height	48.6		48.6	
<b>OPERATING WT. (lbs.)</b>	980		878		
<b>COMPRESSORS</b>	Type	Scroll		Scroll	
	Quantity	2		2	
	Unit Capacity Steps (%)	50/100		50/100	
<b>CONDENSER COIL DATA</b>	Face area (Sq. Ft.)	25.5		25.5	
	Rows	1		1	
	Fins per inch	23		23	
	Tube diameter (in./MM)	1/25		1/25	
	Circuitry Type	2-pass Microchannel		2-pass Microchannel	
<b>EVAPORATOR COIL DATA</b>	Face area (Sq. Ft.)	11.1		11.1	
	Rows	4		4	
	Fins per inch	15		15	
	Tube diameter	0.375		0.375	
	Circuitry Type	Intertwined		Intertwined	
	Refrigerant control	TXV		TXV	

**ZY09 Physical Data (Continued)**

Component	Model						
	ZYG09			ZYE09			
<b>Nominal Tonnage</b>	<b>8.5</b>			<b>8.5</b>			
<b>CONDENSER FAN DATA</b>	Quantity of fans	2			2		
	Fan diameter (Inch)	22			22		
	Type	Prop			Prop		
	Drive type	Direct			Direct		
	Quantity of motors	2			2		
	Motor HP each	1/2			1/2		
	No. speeds	1			1		
	RPM	1085			1085		
Nominal total CFM	8600			8600			
<b>EVAP FAN DATA BELT DRIVE</b>	Airflow Option	A	B	C	A	B	C
	Quantity	1	1	1	1	1	1
	Fan Size (Inch)	15 x 15	15 x 15	15 x 15	15 x 15	15 x 15	15 x 15
	Type	Centrifugal			Centrifugal		
	Motor Sheave	1VL34	1VL44	1VP50	1VL34	1VL44	1VP50
	Blower Sheave	AK74	AK74	AK74	AK74	AK74	AK74
	Belt	A47	A48	A50	A47	A48	A50
	Motor Max Bhp, 3 Phase	2.4	2.4	3.7	2.4	2.4	3.7
	RPM	1725	1725	1725	1725	1725	1725
	Frame size	56Y	56Y	56HZ	56Y	56Y	56HZ
	<b>FILTERS</b>	Quantity - Size	4 - (20 x 20 x 2) <sup>1</sup>			4 - (20 x 20 x 2) <sup>1</sup>	

1. 2 in. Throwaway, Standard, MERV 4 (Minimum Efficiency Reporting Value).

## ZY12 Physical Data

Component		Model			
		ZYG12		ZYE12	
Nominal Tonnage		10		10	
AHRI COOLING PERFORMANCE	Gross Capacity @ AHRI A point (Btu)	123700		123700	
	AHRI net capacity (Btu)	116000		116000	
	EER	11.5		11.7	
	SEER	-		-	
	IEER	12.7		12.9	
	IEER IntelliSpeed	14.0		14.0	
	Nominal CFM	3200		3200	
	System power (KW)	8.90		8.90	
	Refrigerant type	R-410A		R-410A	
	Refrigerant charge (lb-oz)				
	System 1	6-8		6-8	
System 2	7-0		7-0		
AHRI HEATING PERFORMANCE	Heating Options	D	E	F	-
	Heating model	Low	Med	High	-
	1st. Stage Heat input (K Btu)	125	176	200	-
	2nd. Stage Heat input (K Btu)	180	220	250	-
	1st. Stage Heat output (K Btu)	100	141	160	-
	2nd. Stage Heat output (K Btu)	144	176	200	-
	AFUE %				-
	Steady state efficiency (%)	80	80	80	-
	No. burners	4	5	5	-
	No. stages	2	2	2	-
	Temperature Rise Range (°F)	27-44	33-54	37-62	-
	Gas Limit Setting (°F)	150	140	160	-
	Gas piping connection (in.)	3/4	3/4	3/4	-
DIMENSIONS (inches)	Length	87.2		87.2	
	Width	61.7		61.7	
	Height	55.3		55.3	
OPERATING WT. (lbs.)	1008		902		
COMPRESSORS	Type	Scroll		Scroll	
	Quantity	2		2	
	Unit Capacity Steps (%)	50/100		50/100	
CONDENSER COIL DATA	Face area (Sq. Ft.)	24.9		24.9	
	Rows	1		1	
	Fins per inch	21		21	
	Tube diameter (in./MM)	1.26/32		1.26/32	
	Circuitry Type	2-pass Microchannel		2-pass Microchannel	
EVAPORATOR COIL DATA	Face area (Sq. Ft.)	11.1		11.1	
	Rows	4		4	
	Fins per inch	15		15	
	Tube diameter	0.375		0.375	
	Circuitry Type	Intertwined		Intertwined	
	Refrigerant control	TXV		TXV	

**ZY12 Physical Data (Continued)**

Component		Model					
		ZYG12			ZYE12		
<b>Nominal Tonnage</b>		<b>10</b>			<b>10</b>		
<b>CONDENSER FAN DATA</b>							
	Quantity of fans	1			1		
	Fan diameter (Inch)	30			30		
	Type	Prop			Prop		
	Drive type	Direct			Direct		
	Quantity of motors	1			1		
	Motor HP each	1 1/2			1 1/2		
	No. speeds	1			1		
	RPM	1140			1140		
	Nominal total CFM	9700			9700		
<b>EVAP FAN DATA BELT DRIVE</b>							
	Airflow Option	A	B	C	A	B	C
	Quantity	1	1	1	1	1	1
	Fan Size (Inch)	15 x 15	15 x 15	15 x 15	15 x 15	15 x 15	15 x 15
	Type	Centrifugal			Centrifugal		
	Motor Sheave	1VL44	1VP50	1VP56	1VL44	1VP50	1VP56
	Blower Sheave	AK79	AK79	BK85	AK79	AK79	BK85
	Belt	A50	A50	BX52	A50	A50	BX52
	Motor Max Bhp, 3 Phase	2.4	3.7	5.25	2.4	3.7	5.25
	RPM	1725	1725	1725	1725	1725	1725
	Frame size	56Y	56HZ	145TY	56Y	56HZ	145TY
<b>FILTERS</b>	Quantity - Size	4 - (20 x 20 x 2) <sup>1</sup>			4 - (20 x 20 x 2) <sup>1</sup>		

1. 2 in. Throwaway, Standard, MERV 4 (Minimum Efficiency Reporting Value).

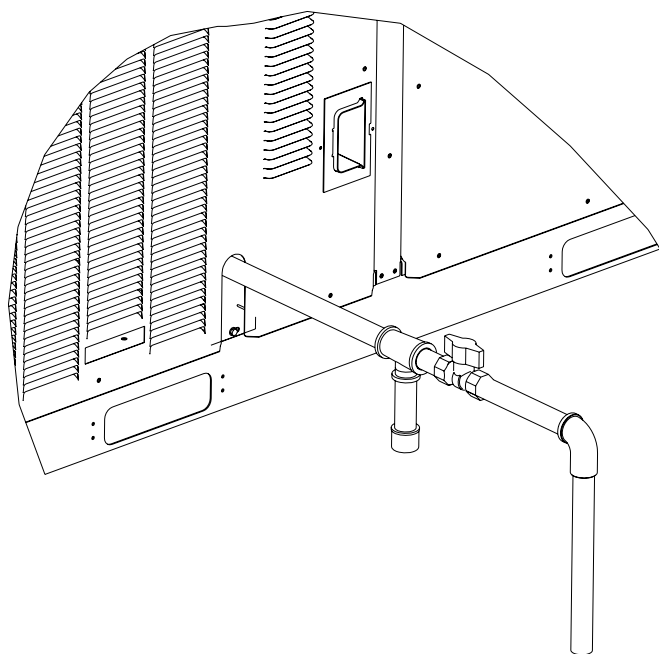


## Optional Gas Heat

These gas-fired heaters have aluminized-steel or optional stainless steel, tubular heat exchangers with spark ignition.

### Gas Piping

Proper sizing of gas piping depends on the cubic feet per hour of gas flow required, specific gravity of the gas and the length of run. "National Fuel Gas Code" Z223.1 (in U.S.A.) or the current Gas Installation Codes CSA-B149.1 (in Canada) should be followed in all cases unless superseded by local codes or gas utility requirements. Refer to the Pipe Sizing Table 11. The heating value of the gas may differ with locality. The value should be checked with the local gas utility.



**Figure 19: Side Entry Gas Piping**

**NOTE:** Routing of gas piping must not interfere with the flue or heat compartment access.

**Table 11: Gas Pipe Sizing - Capacity of Pipe**

Length of Pipe (ft.)	Nominal Iron Pipe Size		
	3/4 in.	1 in.	1-1/4 in.
10	278	520	1050
20	190	350	730
30	152	285	590
40	130	245	500
50	115	215	440
60	105	195	400
70	96	180	370
80	90	170	350
90	84	160	320
100	79	150	305

**NOTE:** Maximum capacity of pipe in cubic feet of gas per hour based upon a pressure drop of 0.3 inch W.C. and 0.6 specific gravity gas.

**NOTE:** There may be a local gas utility requirement specifying a minimum diameter for gas piping. Units require either a 1/2 or 3/4 inch pipe connection at the entrance fitting. Line should not be sized smaller than the entrance fitting size.

**Table 12: Gas Heat Supply Air**

Model (Size)	Gas Heat Description	Opt.	Supply Air (CFM)	
			Heating	
			Min	Max
ZY04 (3)	Low, NOx	L	900	1480
	Low	D	890	1480
	Med, NOx	M	900	1520
	Med	E	1060	1510
ZY05 (4)	Low, NOx	L	1190	1980
	Low	D	1210	1990
	Med, NOx	M	1190	2020
	Med	E	1200	2020
	High, NOx	N	1200	1990
ZY06 (5)	High	F	1390	2190
	Low, NOx	L	1480	2440
	Low	D	1480	2470
	Med, NOx	M	1520	2470
	Med	E	1510	2510
	High, NOx	N	1510	2500
ZY07 (6)	High	F	1490	2500
	Med	E	1820	2990
ZYA7 (6)	High	F	1790	3000
	Med	E	1820	2990
ZY08 (7.5)	Low	D	2260	3700
	Med	E	2260	3700
	High	F	2260	3790
ZY09 (8.5)	Low	D	2570	4210
	Med	E	2560	4300
	High	F	2550	4290
ZY12 (10)	Low	D	3030	4940
	Med	E	3020	4940
	High	F	2990	5010

### Gas Connection

The gas supply line can be routed within the space and roof curb, exiting through the unit's basepan. Refer to Figures 7 thru 11 for the gas piping inlet location. Typical supply piping arrangements are shown in Figure 19. All pipe nipples, fittings, and the gas cock are field supplied.

#### Gas piping recommendations:

1. A drip leg and a ground joint union must be installed in the gas piping.
2. Where required by local codes, a manual shut-off valve must be installed outside of the unit.
3. Use wrought iron or steel pipe for all gas lines. Pipe dope should be applied sparingly to male threads only. If local codes allow the use of a flexible gas appliance connector, always use a new listed connector. Do not use a connector which has previously serviced another gas appliance.

**▲ WARNING**

Natural gas may contain some propane. Propane is an excellent solvent and will quickly dissolve white lead and most standard commercial compounds. A special pipe dope must be used when assembling wrought iron or steel pipe. Shellac based compounds such as Gaskolac or Stalastic, and compounds such as Rectorseal #5, Clydes's or John Crane may be used.

4. All piping should be cleaned of dirt and scale by hammering on the outside of the pipe and blowing out loose particles. Before initial start-up, be sure that all gas lines external to the unit have been purged of air.
5. The gas supply should be a separate line and installed in accordance with all safety codes as prescribed under "Limitations".
6. A 1/8-inch NPT plugged tapping, accessible for test gauge connection, must be installed immediately upstream of the gas supply connection to the unit.
7. After the gas connections have been completed, open the main shut-off valve admitting *normal gas pressure* to the mains. *Check all joints for leaks with soap solution or other material suitable for the purpose. NEVER USE A FLAME.*

**▲ WARNING****FIRE OR EXPLOSION HAZARD**

Failure to follow the safety warning exactly could result in serious injury, death or property damage.

Never test for gas leaks with an open flame. Use a commercially available soap solution made specifically for the detection of leaks to check all connections. A fire or explosion may result causing property damage, personal injury or loss of life.

**▲ CAUTION**

The furnace and its individual shut-off valve must be disconnected from the gas supply piping system during any pressure testing at pressures in excess of 1/2 PSIG. Pressures greater than 1/2 PSIG will cause gas valve damage resulting in a hazardous condition. If it is subjected to a pressure greater than 1/2 PSIG, the gas valve must be replaced.

The furnace must be isolated from the gas supply piping system by closing its individual manual shut-off valve during any pressure testing of the gas supply piping system at test pressures equal to or less than 1/2 PSIG.

**▲ WARNING**

Threaded joints should be coated with a sealing compound that is resistant to the action of liquefied petroleum gases. **Do not use Teflon tape.**

Check all connections for leaks when piping is completed using a soap solution. **NEVER USE A FLAME.**

**▲ WARNING****FIRE OR EXPLOSION HAZARD**

Failure to follow the safety warning exactly could result in serious injury, death or property damage.

Never test for gas leaks with an open flame. Use a commercially available soap solution made specifically for the detection of leaks to check all connections. A fire or explosion may result causing property damage, personal injury or loss of life.

**Combustion Air and Flue Exhaust**

Venting slots in the heating compartment access panel remove the need for a combustion air hood. The gas heat flue exhaust is routed from the unit through a field installed exhaust hood with screen (See Figure 20 for location of hood within the unit and Figure 21 for Installation of the hood. If necessary, a flue exhaust extension may be installed at the point of installation.



**Figure 20: Flue Exhaust Hood Shipping Location**



**Figure 21: Flue Exhaust Hood Installed**

## Options/Accessories

### Economizer

The Economizer can be a factory installed option or a field installed accessory. If factory installed, refer to the instructions included with the outdoor air hood to complete the assembly. Field installed Economizer accessories include complete instructions for installation.

There are two Economizer options. Each is specific to footprint and unit voltage:

1. Vertical Flow application with barometric relief standard.
2. Horizontal Flow application with barometric relief standard.

### Power Exhaust

The Power Exhaust is a field installed accessory. Field installed Power Exhaust accessories include complete instructions for installation.

The Power Exhaust factory installed option is for Down Flow application only.

There are two field installed Power Exhaust accessories:

1. Down Flow application.
2. Horizontal Flow application that requires the purchase of a barometric relief hood.

### Rain Hood

All of the hood components, including the mist eliminators, the gasketing and the hardware for assembling, are packaged and located between the condenser coil section and the main unit cabinet, if the unit has factory installed options. If field installed

accessories are being installed all parts necessary for the installation comes in the accessory.

### Blower Phasing

ZY units are properly phased at the factory. Check for proper blower rotation. If the blower rotates in the wrong direction at start-up, the electrical connection to the unit is misphased. Change the phasing of the **Field Line Connection at the factory or field supplied disconnect** to obtain proper rotation.

## CAUTION

When installing equipment in a facility with a 3 phase high-leg delta power supply, care must be taken to ensure that the high-leg conductor is not attached to either of the two legs of the (single phase, direct drive) X13 or ECM motors. Failure to do so can result in the motor acting erratically or not running at all.

Check for the high leg conductor by checking voltage of each phase to ground.

Example: A or L1 phase to ground, voltage reading is 120V. B or L2 phase to ground, voltage reading is 195 to 208V. C or L3 phase to ground, voltage reading is 120V. Therefore B or L2 phase is the high Leg. The high should always be wired to the center or B or L2 tap.

**Note:** Check all three phase motors and compressors for proper rotation after making a change. If it is necessary to change 3 phase motor rotation, swap A or L1 and C or L3 only.

### Blower Rotation

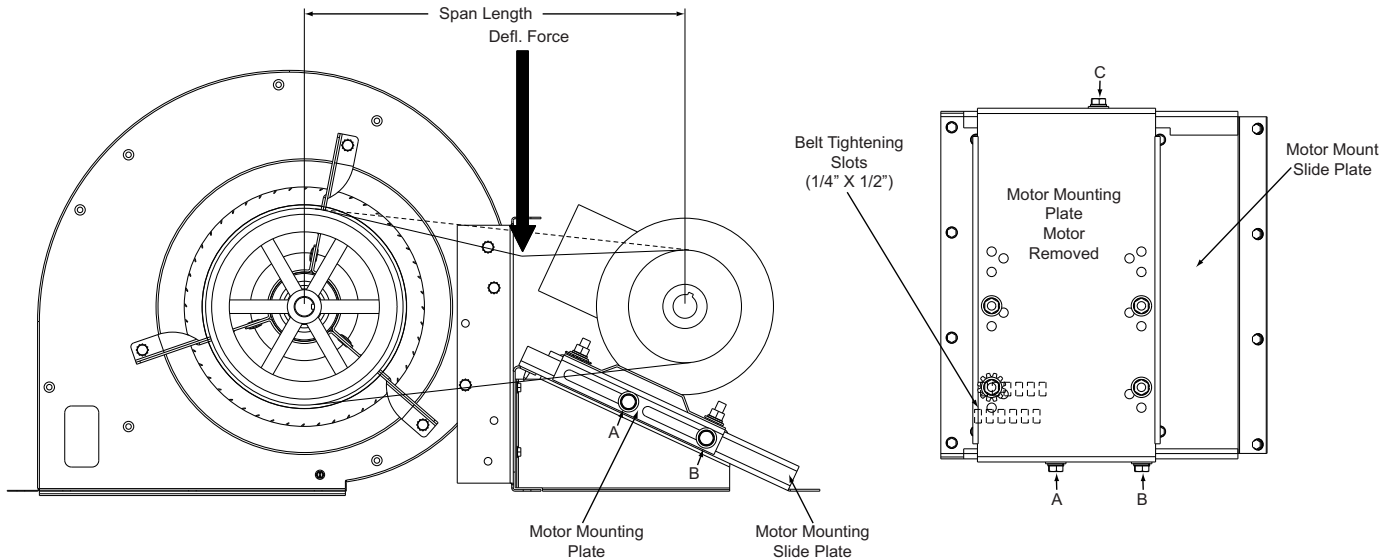
Check for proper supply air blower rotation. If the blower is rotating backwards, the line voltage at the unit point of power connection is misphased (See 'BLOWER PHASING').

**Table 13: Supply Air Limitations**

Model (Size)	Supply Air (CFM)	
	Minimum	Maximum
ZY04 (3)	900	1500
ZY05 (4)	1200	2000
ZY06 (5)	1500	2500
ZY07 (6)	1800	3000
ZYA7 (6)	1800	3000
ZY08 (7.5)	2250	3750
ZY09 (8.5)	2550	4250
ZY12 (10)	3000	5000

## Belt Tension

The tension on the belt should be adjusted as shown in Figure 22.



**Figure 22: Belt Adjustment**

### CAUTION

Procedure for adjusting belt tension:

1. Loosen the three nuts (A and B on side and C on back) of motor mount slide plate.
2. Adjust tension by placing a flat heat screwdriver into the belt tightening slots (1/4" X 1/2") in the motor mount slide plate and applying pressure against the motor mounting plate. See Figure 22.
3. Tighten the three loosened nuts (A, B and C).
4. Determine the deflection distance from normal position, use a straight edge from sheave to sheave as reference line. Use belt tension checker to apply a perpendicular force to the belt at the midpoint of the span as shown. Deflection distance of 4mm (5/32") is obtained.
5. After adjustments are completed re-tighten nuts (A, B and C).

### Altitude and Temperature Correction for CFM, Static Pressure and Power.

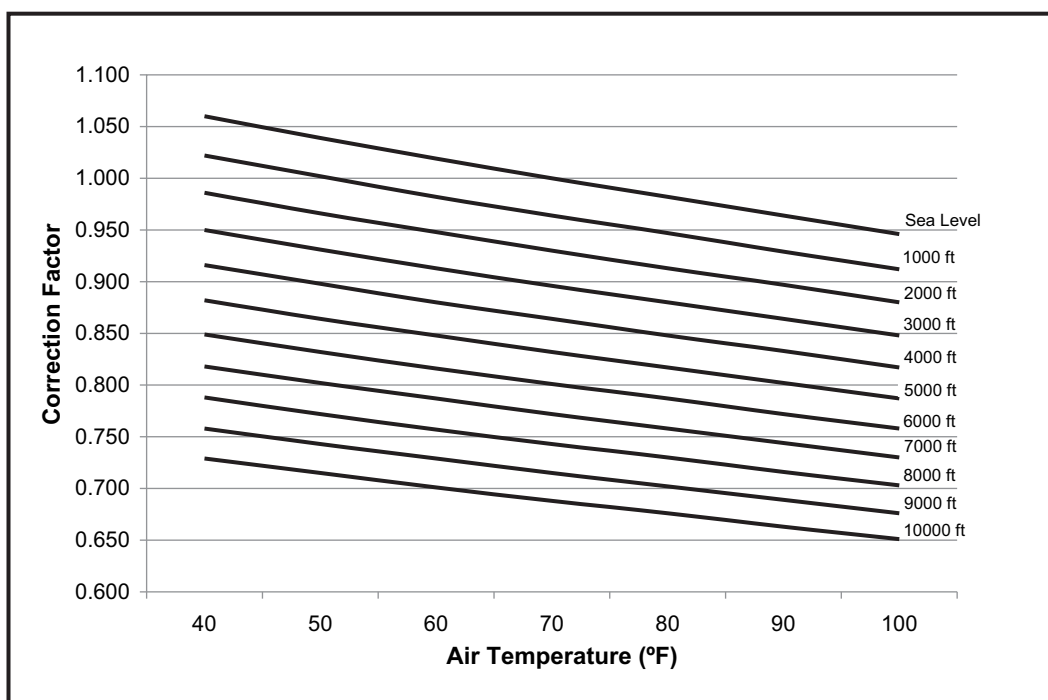
The information below should be used to assist in application of product when being applied at altitudes at or exceeding 1000 feet above sea level.

The air flow rates listed in the standard blower performance tables are based on standard air at sea level. As the altitude or temperature increases, the density of air decreases. In order to use the indoor blower tables for high altitude applications, certain corrections are necessary.

A centrifugal fan is a "constant volume" device. This means that, if the rpm remains constant, the CFM delivered is the same regardless of the density of the air. However, since the air at high altitude is less dense, less static pressure will be generated and less power will be required than a similar application at sea level. Air density correction factors are shown in Table 14 and Figure 23.

**Table 14: Altitude/Temperature Correction Factors**

Air Temp.	Altitude (Ft.)										
	0	1000	2000	3000	4000	5000	6000	7000	8000	9000	10000
40	1.060	1.022	0.986	0.950	0.916	0.882	0.849	0.818	0.788	0.758	0.729
50	1.039	1.002	0.966	0.931	0.898	0.864	0.832	0.802	0.772	0.743	0.715
60	1.019	0.982	0.948	0.913	0.880	0.848	0.816	0.787	0.757	0.729	0.701
70	1.000	0.964	0.930	0.896	0.864	0.832	0.801	0.772	0.743	0.715	0.688
80	0.982	0.947	0.913	0.880	0.848	0.817	0.787	0.758	0.730	0.702	0.676
90	0.964	0.929	0.897	0.864	0.833	0.802	0.772	0.744	0.716	0.689	0.663
100	0.946	0.912	0.880	0.848	0.817	0.787	0.758	0.730	0.703	0.676	0.651

**Figure 23: Altitude/Temperature Correction Factors**

The examples below will assist in determining the airflow performance of the product at altitude.

**Example 1:** What are the corrected CFM, static pressure, and BHP at an elevation of 5,000 ft. if the airflow performance data is 3,000 CFM, 1.4 IWC and 2.0 BHP?

**Solution:** At an elevation of 5,000 ft. the indoor blower will still deliver 3,000 CFM if the rpm is unchanged. However, the Altitude correction must be used to determine the static pressure and BHP. Since no temperature data is given, we will assume an Air Temperature of 70°F. The Altitude/Temperature Factors show the correction factor to be 0.832.

$$\text{Corrected static pressure} = 1.4 \times 0.832 = 1.16 \text{ IWC}$$

$$\text{Corrected BHP} = 2.0 \times 0.832 = 1.66$$

**Example 2:** A system, located at 5,000 feet of elevation, is to deliver 3,000 CFM at a static pressure of 1.4". Use the unit blower tables to select the blower speed and the BHP requirement.

**Solution:** As in the example above, no temperature information is given so 70°F is assumed.

The 1.4" static pressure given is at an elevation of 5,000 ft. The first step is to convert this static pressure to equivalent sea level conditions.

$$\text{Sea level static pressure} = 1.4" / .832 = 1.68"$$

Enter the Supply Air Blower Performance Table at 3,000 CFM and static pressure of 1.68". The rpm listed will be the same rpm needed at 5,000 ft.

Suppose that the corresponding BHP listed in the table is 2.0. This value must be corrected for elevation.

$$\text{BHP at 5,000 ft.} = 2.0 \times .832 = 1.66$$

**Drive Selection**

1. Determine side or bottom supply duct Application.
2. Determine desired airflow.
3. Calculate or measure the amount of external static pressure.
  - Add or deduct any additional static resistance from “Additional Static Resistance Table”.
4. Using the operating point determined from steps 1, 2 & 3, locate this point on the appropriate supply air blower performance table. (Linear interpolation may be necessary.)
5. Noting the RPM and BHP from step 4, locate the appropriate motor and, or drive.
6. Review the BHP compared to the motor options available. Select the appropriate motor and, or drive.
7. Review the RPM range for the motor options available. Select the appropriate drive if multiple drives are available for the chosen motor.
8. Determine turns open to obtain the desired operation point.

**Example**

1. 3400 CFM
2. 1.6 iwg
3. Using the airflow performance table below, the following data point was located: 1039 RPM & 2.52 BHP.
4. Using the RPM selection table below, Model ZY and Size 08 (Tons) 7.5 is found.
5. 2.59 BHP exceeds the maximum continuous BHP rating of the 1.5 HP motor. The 3 HP motor is required.
6. 1039 RPM is within the range of the 3 HP drives.
7. Using the 3 HP motor and drive, 1.5 turns open will achieve 1039 RPM.

**Airflow Performance**

**Example Supply Air Blower Performance  
ZY08 (7.5 Ton) Bottom Duct**

CFM	Available External Static																			
	0.2		0.4		0.6		0.8		1.0		1.2		1.4		1.6		1.8		2.0	
	RPM	BHP	RPM	BHP	RPM	BHP	RPM	BHP	RPM	BHP	RPM	BHP	RPM	BHP	RPM	BHP	RPM	BHP	RPM	BHP
2250	556	0.45	621	0.65	683	0.83	742	1.00	798	1.18	852	1.34	904	1.51	954	1.69	1003	1.87	1050	2.06
2400	567	0.53	632	0.73	694	0.91	753	1.09	809	1.26	863	1.43	914	1.60	964	1.77	1013	1.95	1060	2.14
2600	580	0.65	646	0.85	707	1.03	766	1.21	823	1.38	876	1.55	928	1.72	978	1.89	1027	2.07	1074	2.27
2800	595	0.79	660	0.99	722	1.17	780	1.35	837	1.52	890	1.69	942	1.86	992	2.03	1041	2.21	1088	2.40
3000	609	0.94	674	1.14	736	1.32	795	1.50	851	1.67	905	1.83	957	2.00	1007	2.18	1056	2.36	1100	2.55
3200	625	1.10	690	1.30	752	1.48	810	1.66	867	1.83	921	2.00	972	2.17	1022	2.34	1071	2.52	--	--
3400	641	1.28	706	1.47	768	1.66	827	1.83	883	2.00	937	2.17	989	2.34	1039	2.52	1087	2.70	--	--

- Standard Static Option with Motor rated at 2.4-hp
- Medium Static Option with Motor rated at 2.4-hp
- High Static Option with Motor rated at 3.7-hp
- Exceeds recommended blower speed

**Example RPM Selection**

Model	Size (Tons)	Airflow Option	Phase	Max BHP	Blower Sheave	Motor Sheave	6 Turns Open	5 Turns Open	4 Turns Open	3 Turns Open	2 Turns Open	1 Turns Open	Fully Closed
ZY	08 (7.5)	Std.	3	2.4	AK74	1VL34	N/A	475	525	575	625	675	725
		Med.	3	2.4	AK74	1VL44	N/A	700	750	800	850	900	950
		H. Static	3	3.7	AK74	1VP50	N/A	850	900	950	1000	1050	1100

**Example Additional Static Resistance**

Model	Size (Tons)	CFM	Cooling Only <sup>1</sup>	Economizer <sup>2,3</sup>	4" Filters <sup>2</sup>	Electric Heat kW <sup>2</sup>								
						6/6.5	9.2/10.5/11	13.8/14/16	16/16.5/17	23	24.8/25.5/27.8	32/33/34	41.7/42.4	
ZY	08 (7.5), 09 (8.5), 12 (10.0)	2200	0.04	0.11	---	---	---	---	0.07	---	0.09	0.10	0.12	
		2600	0.06	0.13	---	---	---	---	0.09	---	0.11	0.12	0.15	
		3000	0.10	0.17	---	---	---	---	---	0.12	---	0.14	0.15	0.19
		3400	0.13	0.20	---	---	---	---	---	0.15	---	0.18	0.19	0.23
		3800	0.16	0.25	---	---	---	---	---	0.19	---	0.22	0.23	0.27
		4000	0.17	0.28	---	---	---	---	---	0.21	---	0.24	0.25	0.30
		4400	0.20	0.33	---	---	---	---	---	0.25	---	0.29	0.30	0.35
		4800	0.22	0.38	---	---	---	---	---	0.30	---	0.34	0.35	0.41
		5200	0.24	0.43	---	---	---	---	---	0.35	---	0.39	0.41	0.47
		5600	0.26	0.46	---	---	---	---	---	0.41	---	0.45	0.47	0.54
6000	0.28	0.50	---	---	---	---	---	0.48	---	0.52	0.54	0.60		

Table 15: ZY04-12 Side Duct Application (Belt Drive)

## ZY04 (3.0 Ton) Side Duct

CFM	Available External Static																			
	0.2		0.4		0.6		0.8		1.0		1.2		1.4		1.6		1.8		2.0	
	RPM	BHP	RPM	BHP	RPM	BHP	RPM	BHP	RPM	BHP	RPM	BHP	RPM	BHP	RPM	BHP	RPM	BHP	RPM	BHP
900			874	0.31	972	0.40	1065	0.50	1153	0.60	1236	0.70	1315	0.80	1390	0.89	1460	0.97	1526	1.05
1000			887	0.36	985	0.45	1078	0.55	1165	0.65	1249	0.75	1328	0.85	1402	0.94	1472	1.03	1539	1.10
1100	797	0.33	900	0.42	998	0.51	1091	0.61	1179	0.71	1263	0.81	1341	0.91	1416	1.00	1486	1.08	1553	1.16
1200	813	0.40	916	0.48	1014	0.57	1107	0.67	1195	0.77	1279	0.87	1357	0.97	1432	1.06	1502	1.15	1569	1.22
1300	831	0.46	935	0.55	1033	0.64	1126	0.74	1214	0.84	1297	0.94	1376	1.03	1450	1.13	1520	1.21	1583	1.28
1400	852	0.53	956	0.61	1054	0.71	1146	0.80	1234	0.90	1318	1.00	1396	1.10	1471	1.19	1541	1.28	--	--
1500	876	0.59	979	0.68	1077	0.77	1170	0.87	1258	0.97	1341	1.07	1420	1.17	1494	1.26	1565	1.34	--	--

$$\text{kW} = 0.929 \times \text{BHP}$$

	Medium Static Option with Motor rated at 2.4-hp
	High Static Option with Motor rated at 2.9-hp
	Exceeds recommended blower speed

## ZY05 (4.0 Ton) Side Duct

CFM	Available External Static																			
	0.2		0.4		0.6		0.8		1.0		1.2		1.4		1.6		1.8		2.0	
	RPM	BHP	RPM	BHP	RPM	BHP	RPM	BHP	RPM	BHP	RPM	BHP	RPM	BHP	RPM	BHP	RPM	BHP	RPM	BHP
1200	840	0.30	927	0.41	1012	0.53	1096	0.65	1177	0.77	1257	0.89	1334	1.01	1411	1.12	1485	1.22	1558	1.31
1300	857	0.35	944	0.47	1029	0.59	1112	0.71	1194	0.83	1273	0.95	1351	1.07	1427	1.18	1502	1.28	1574	1.37
1400	875	0.42	962	0.53	1048	0.65	1131	0.77	1212	0.89	1292	1.01	1370	1.13	1446	1.24	1520	1.34	1593	1.43
1500	897	0.49	984	0.60	1069	0.72	1152	0.84	1233	0.96	1313	1.08	1391	1.20	1467	1.31	1542	1.41	--	--
1600	921	0.56	1008	0.67	1093	0.79	1176	0.91	1258	1.04	1337	1.16	1415	1.27	1491	1.38	1566	1.49	--	--
1700	948	0.64	1035	0.76	1120	0.87	1204	1.00	1285	1.12	1365	1.24	1442	1.36	1518	1.47	1593	1.57	--	--
1800	979	0.73	1066	0.85	1151	0.96	1234	1.08	1315	1.21	1395	1.33	1473	1.44	1549	1.56	--	--	--	--
1900	1012	0.83	1099	0.94	1185	1.06	1268	1.18	1349	1.30	1429	1.42	1507	1.54	1583	1.65	--	--	--	--
2000	1049	0.93	1136	1.04	1222	1.16	1305	1.28	1386	1.40	1466	1.52	1544	1.64	--	--	--	--	--	--

$$\text{kW} = 0.929 \times \text{BHP}$$

	Medium Static Option with Motor rated at 2.4-hp
	High Static Option with Motor rated at 2.9-hp
	Exceeds recommended blower speed

## ZY06 (5.0 Ton) Side Duct

CFM	Available External Static																			
	0.2		0.4		0.6		0.8		1.0		1.2		1.4		1.6		1.8		2.0	
	RPM	BHP	RPM	BHP	RPM	BHP	RPM	BHP	RPM	BHP	RPM	BHP	RPM	BHP	RPM	BHP	RPM	BHP	RPM	BHP
1500	810	0.49	883	0.60	954	0.70	1023	0.80	1089	0.91	1152	1.02	1213	1.14	1269	1.26	1323	1.40	1373	1.55
1600	831	0.58	904	0.68	975	0.79	1044	0.89	1110	1.00	1173	1.11	1233	1.22	1290	1.35	1344	1.49	1394	1.64
1700	854	0.66	927	0.77	998	0.87	1067	0.98	1133	1.08	1196	1.19	1256	1.31	1313	1.44	1367	1.57	1417	1.72
1800	878	0.75	952	0.86	1023	0.96	1091	1.07	1157	1.17	1221	1.28	1281	1.40	1338	1.52	1391	1.66	1441	1.81
1900	904	0.84	977	0.95	1048	1.05	1117	1.16	1183	1.26	1246	1.37	1306	1.49	1363	1.61	1417	1.75	1467	1.90
2000	931	0.93	1004	1.04	1075	1.15	1144	1.25	1210	1.36	1273	1.47	1333	1.58	1390	1.71	1444	1.84	1494	1.99
2100	959	1.03	1032	1.14	1103	1.24	1172	1.35	1238	1.45	1301	1.56	1361	1.68	1418	1.81	1472	1.94	1522	2.09
2200	988	1.13	1061	1.24	1132	1.35	1201	1.45	1267	1.56	1330	1.67	1390	1.78	1447	1.91	1501	2.04	1550	2.19
2300	1017	1.24	1091	1.35	1162	1.45	1230	1.56	1296	1.66	1359	1.77	1420	1.89	1477	2.02	1530	2.15	1580	2.30
2400	1047	1.36	1121	1.46	1192	1.57	1260	1.67	1326	1.78	1390	1.89	1450	2.01	1507	2.13	1560	2.27	--	--
2500	1078	1.48	1151	1.58	1222	1.69	1291	1.79	1357	1.90	1420	2.01	1480	2.13	1537	2.25	1591	2.39	--	--

	Medium Static Option with Motor rated at 2.4-hp
	High Static Option with Motor rated at 2.9-hp
	Exceeds recommended blower speed

**ZY07 (6.0 Ton) Side Duct**

CFM	Available External Static																			
	0.2		0.4		0.6		0.8		1.0		1.2		1.4		1.6		1.8		2.0	
	RPM	BHP	RPM	BHP	RPM	BHP	RPM	BHP	RPM	BHP	RPM	BHP	RPM	BHP	RPM	BHP	RPM	BHP	RPM	BHP
1800	521	0.27	583	0.44	644	0.63	703	0.81	759	0.99	814	1.17	866	1.34	916	1.51	964	1.67	1010	1.83
1900	529	0.31	591	0.49	651	0.67	710	0.85	767	1.03	821	1.21	874	1.39	924	1.56	972	1.72	1017	1.87
2000	536	0.36	598	0.54	659	0.72	718	0.90	774	1.08	829	1.26	881	1.44	931	1.61	979	1.77	1025	1.92
2100	544	0.42	606	0.59	667	0.77	725	0.95	782	1.14	836	1.32	889	1.49	939	1.66	987	1.82	1032	1.97
2200	551	0.47	614	0.65	674	0.83	733	1.01	789	1.19	844	1.37	896	1.55	947	1.72	994	1.88	1040	2.03
2300	559	0.53	622	0.71	682	0.89	741	1.07	797	1.25	852	1.43	904	1.61	954	1.77	1002	1.94	1048	2.09
2400	567	0.59	630	0.77	690	0.95	749	1.13	805	1.31	860	1.49	912	1.67	962	1.84	1010	2.00	1056	2.15
2500	575	0.66	638	0.83	698	1.01	757	1.20	813	1.38	868	1.56	920	1.73	970	1.90	1018	2.06	1064	2.22
2600	584	0.73	646	0.90	707	1.08	765	1.26	822	1.45	876	1.63	929	1.80	979	1.97	1027	2.13	1072	2.28
2700	592	0.80	655	0.97	715	1.15	774	1.34	830	1.52	885	1.70	937	1.87	987	2.04	1035	2.20	1081	2.36
2800	601	0.87	664	1.05	724	1.23	783	1.41	839	1.59	894	1.77	946	1.95	996	2.12	1044	2.28	1090	2.43
2900	610	0.95	673	1.13	733	1.31	792	1.49	848	1.67	903	1.85	955	2.03	1005	2.20	1053	2.36	1099	2.51
3000	619	1.03	682	1.21	742	1.39	801	1.57	858	1.75	912	1.93	964	2.11	1015	2.28	1063	2.44	--	--

Standard Static Option with Motor rated at 2.4-hp  
 Medium Static Option with Motor rated at 2.9-hp  
 High Static Option with Motor rated at 3.7-hp  
 Exceeds recommended blower speed

**ZYA7 (6.0 Ton) Side Duct**

CFM	Available External Static																			
	0.2		0.4		0.6		0.8		1.0		1.2		1.4		1.6		1.8		2.0	
	RPM	BHP	RPM	BHP	RPM	BHP	RPM	BHP	RPM	BHP	RPM	BHP	RPM	BHP	RPM	BHP	RPM	BHP	RPM	BHP
1800	521	0.27	583	0.44	644	0.63	703	0.81	759	0.99	814	1.17	866	1.34	916	1.51	964	1.67	1010	1.83
1900	529	0.31	591	0.49	651	0.67	710	0.85	767	1.03	821	1.21	874	1.39	924	1.56	972	1.72	1017	1.87
2000	536	0.36	598	0.54	659	0.72	718	0.90	774	1.08	829	1.26	881	1.44	931	1.61	979	1.77	1025	1.92
2100	544	0.42	606	0.59	667	0.77	725	0.95	782	1.14	836	1.32	889	1.49	939	1.66	987	1.82	1032	1.97
2200	551	0.47	614	0.65	674	0.83	733	1.01	789	1.19	844	1.37	896	1.55	947	1.72	994	1.88	1040	2.03
2300	559	0.53	622	0.71	682	0.89	741	1.07	797	1.25	852	1.43	904	1.61	954	1.77	1002	1.94	1048	2.09
2400	567	0.59	630	0.77	690	0.95	749	1.13	805	1.31	860	1.49	912	1.67	962	1.84	1010	2.00	1056	2.15
2500	575	0.66	638	0.83	698	1.01	757	1.20	813	1.38	868	1.56	920	1.73	970	1.90	1018	2.06	1064	2.22
2600	584	0.73	646	0.90	707	1.08	765	1.26	822	1.45	876	1.63	929	1.80	979	1.97	1027	2.13	1072	2.28
2700	592	0.80	655	0.97	715	1.15	774	1.34	830	1.52	885	1.70	937	1.87	987	2.04	1035	2.20	1081	2.36
2800	601	0.87	664	1.05	724	1.23	783	1.41	839	1.59	894	1.77	946	1.95	996	2.12	1044	2.28	1090	2.43
2900	610	0.95	673	1.13	733	1.31	792	1.49	848	1.67	903	1.85	955	2.03	1005	2.20	1053	2.36	1099	2.51
3000	619	1.03	682	1.21	742	1.39	801	1.57	858	1.75	912	1.93	964	2.11	1015	2.28	1063	2.44	--	--

Standard Static Option with Motor rated at 2.4-hp  
 Medium Static Option with Motor rated at 2.9-hp  
 High Static Option with Motor rated at 3.7-hp  
 Exceeds recommended blower speed

**ZY08 (7.5 Ton) Side Duct**

CFM	Available External Static																			
	0.2		0.4		0.6		0.8		1.0		1.2		1.4		1.6		1.8		2.0	
	RPM	BHP	RPM	BHP	RPM	BHP	RPM	BHP	RPM	BHP	RPM	BHP	RPM	BHP	RPM	BHP	RPM	BHP	RPM	BHP
2250	547	0.39	610	0.60	670	0.81	727	1.01	783	1.21	836	1.41	888	1.59	939	1.78	989	1.96	1038	2.13
2400	556	0.47	619	0.69	679	0.90	736	1.10	792	1.30	845	1.49	897	1.68	948	1.86	998	2.04	1047	2.22
2600	568	0.60	631	0.81	691	1.02	749	1.22	804	1.42	857	1.61	909	1.80	960	1.99	1010	2.17	1059	2.34
2800	581	0.73	644	0.95	704	1.16	762	1.36	817	1.56	871	1.75	923	1.94	973	2.13	1023	2.31	1073	2.48
3000	595	0.89	658	1.10	718	1.31	776	1.51	831	1.71	885	1.91	937	2.09	988	2.28	1038	2.46	1087	2.63
3200	610	1.05	673	1.27	733	1.48	791	1.68	846	1.88	900	2.07	952	2.26	1003	2.44	1053	2.62	--	--
3400	627	1.23	689	1.45	750	1.66	807	1.86	863	2.06	916	2.25	968	2.44	1019	2.62	1069	2.80	--	--
3600	644	1.42	707	1.64	767	1.85	824	2.05	880	2.25	933	2.44	985	2.63	1036	2.82	1086	3.00	--	--
3750	657	1.58	720	1.79	780	2.00	838	2.20	893	2.40	947	2.60	999	2.78	1049	2.97	1099	3.15	--	--

Standard Static Option with Motor rated at 2.4-hp  
 Medium Static Option with Motor rated at 2.4-hp  
 High Static Option with Motor rated at 3.7-hp  
 Exceeds recommended blower speed



## ZY09 (8.5 Ton) Side Duct

CFM	Available External Static																			
	0.2		0.4		0.6		0.8		1.0		1.2		1.4		1.6		1.8		2.0	
	RPM	BHP	RPM	BHP	RPM	BHP	RPM	BHP	RPM	BHP	RPM	BHP	RPM	BHP	RPM	BHP	RPM	BHP	RPM	BHP
2550	565	0.56	628	0.78	688	0.99	745	1.19	801	1.39	854	1.58	906	1.77	957	1.95	1007	2.13	1056	2.31
2600	568	0.60	631	0.81	691	1.02	749	1.22	804	1.42	857	1.61	909	1.80	960	1.99	1010	2.17	1059	2.34
2800	581	0.73	644	0.95	704	1.16	762	1.36	817	1.56	871	1.75	923	1.94	973	2.13	1023	2.31	1073	2.48
3000	595	0.89	658	1.10	718	1.31	776	1.51	831	1.71	885	1.91	937	2.09	988	2.28	1038	2.46	1087	2.63
3200	610	1.05	673	1.27	733	1.48	791	1.68	846	1.88	900	2.07	952	2.26	1003	2.44	1053	2.62	1100	2.80
3400	627	1.23	689	1.45	750	1.66	807	1.86	863	2.06	916	2.25	968	2.44	1019	2.62	1069	2.80	--	--
3600	644	1.42	707	1.64	767	1.85	824	2.05	880	2.25	933	2.44	985	2.63	1036	2.82	1086	3.00	--	--
3800	662	1.63	725	1.84	785	2.05	842	2.26	898	2.46	951	2.65	1003	2.84	1054	3.02	1100	3.20	--	--
4000	681	1.85	744	2.06	804	2.27	861	2.47	917	2.67	970	2.87	1022	3.05	1073	3.24	--	--	--	--
4200	701	2.08	764	2.29	824	2.50	881	2.70	937	2.90	990	3.09	1042	3.28	1093	3.47	--	--	--	--
4250	706	2.14	769	2.35	829	2.56	887	2.76	942	2.96	996	3.15	1048	3.34	1098	3.53	--	--	--	--

	Standard Static Option with Motor rated at 2.4-hp
	Medium Static Option with Motor rated at 2.4-hp
	High Static Option with Motor rated at 3.7-hp
<b></b>	Field-supplied AK79 x 1 fixed pulley (p/n 9381) with Motor rated at 3.7-hp
	Exceeds recommended blower speed

## ZY12 (10 Ton) Side Duct

CFM	Available External Static																			
	0.2		0.4		0.6		0.8		1.0		1.2		1.4		1.6		1.8		2.0	
	RPM	BHP	RPM	BHP	RPM	BHP	RPM	BHP	RPM	BHP	RPM	BHP	RPM	BHP	RPM	BHP	RPM	BHP	RPM	BHP
3000	653	0.79	706	1.02	758	1.25	808	1.49	858	1.72	907	1.95	955	2.18	1003	2.40	1049	2.62	1095	2.82
3200	667	0.94	720	1.17	771	1.40	822	1.64	872	1.88	921	2.11	969	2.34	1016	2.56	1063	2.77	1109	2.97
3400	682	1.11	734	1.34	786	1.57	837	1.81	887	2.04	936	2.28	984	2.50	1031	2.73	1078	2.94	1124	3.14
3600	697	1.29	750	1.52	802	1.76	853	1.99	903	2.23	952	2.46	1000	2.69	1047	2.91	1094	3.12	1140	3.32
3800	714	1.50	767	1.73	819	1.96	870	2.20	920	2.43	969	2.67	1017	2.90	1064	3.12	1111	3.33	1157	3.53
4000	733	1.73	786	1.96	837	2.19	888	2.43	938	2.66	987	2.90	1035	3.12	1083	3.34	1129	3.56	1174	3.76
4200	753	1.98	806	2.21	857	2.44	908	2.68	958	2.91	1007	3.15	1055	3.37	1102	3.60	1149	3.81	--	--
4400	774	2.25	827	2.48	879	2.72	930	2.95	979	3.19	1028	3.42	1076	3.65	1124	3.87	1170	4.08	--	--
4600	797	2.55	850	2.78	902	3.02	952	3.25	1002	3.49	1051	3.72	1099	3.95	1147	4.17	--	--	--	--
4800	822	2.88	874	3.11	926	3.34	977	3.58	1027	3.81	1076	4.05	1124	4.27	1171	4.50	--	--	--	--
5000	848	3.23	901	3.46	952	3.69	1003	3.93	1053	4.16	1102	4.40	1150	4.62	--	--	--	--	--	--

	Standard Static Option with Motor rated at 2.4-hp
	Medium Static Option with Motor rated at 3.7-hp
	High Static Option with Motor rated at 5.25-hp
	Exceeds recommended blower speed

**Table 16: ZY04-06 Side Duct Application (Direct Drive)****ZY04-06 Side Duct (Cooling)**

Unit (Ton)	Motor Speed	Available External Static														
		0.2			0.4			0.6			0.8			1.0		
		CFM	WATTS	RPM	CFM	WATTS	RPM	CFM	WATTS	RPM	CFM	WATTS	RPM	CFM	WATTS	RPM
ZY04 (3)	1 (LOW)	987	120	651	813	145	774	698	162	864	541	180	959	383	201	1047
	2 (MED/LOW)	1079	144	677	936	171	795	793	190	886	692	214	975	521	232	1063
	3 (MED)	1153	166	701	1037	195	812	875	221	913	786	239	986	654	263	1076
	4 (MED/HI)	1191	178	712	1086	206	815	927	233	916	837	257	998	711	278	1083
	5 (HI)	1326	229	757	1235	261	856	1124	291	951	973	319	1035	896	336	1099
ZY05 (4)	1 (LOW)	1302	207	727	1188	240	841	1037	266	933	941	296	1022	882	318	1098
	2 (MED/LOW)	1421	247	757	1323	282	861	1209	315	958	1064	346	1043	993	368	1116
	3 (MED)	1538	297	795	1453	332	888	1343	367	982	1216	396	1058	1093	427	1146
	4 (MED/HI)	1571	315	809	1496	352	898	1385	389	996	1288	420	1072	1135	444	1147
	5 (HI)	1779	432	878	1707	470	960	1615	511	1042	1516	544	1123	1165	468	1160
ZY06 (5)	1 (LOW)	1588	298	695	1517	330	761	1409	358	835	1273	393	913	1167	418	973
	2 (MED/LOW)	1624	321	713	1557	352	777	1464	383	845	1315	418	924	1224	446	983
	3 (MED)	1942	504	792	1881	536	852	1800	565	908	1714	605	969	1611	644	1038
	4 (MED/HI)	2146	631	840	2064	692	908	2001	713	954	1932	757	1007	1843	794	1065
	5 (HI)	2316	812	892	2240	861	954	2181	894	1000	2113	938	1045	2003	946	1093

**ZY04-06 Side Duct (Gas Heat)**

Unit (Ton)	Motor Speed	Available External Static														
		0.2			0.4			0.6			0.8			1.0		
		CFM	WATTS	RPM	CFM	WATTS	RPM	CFM	WATTS	RPM	CFM	WATTS	RPM	CFM	WATTS	RPM
ZY04 (3)	1 (LOW)	978	125	684	853	149	797	734	172	906	596	190	998	445	203	1068
	2 (MED/LOW)	1078	153	721	962	175	817	846	200	922	726	226	1026	599	241	1098
	3 (MED)	1153	178	748	1045	199	837	934	226	937	831	251	1031	709	272	1114
	4 (MED/HI)	1315	248	819	1239	272	895	1138	300	980	1037	323	1062	922	343	1144
	5 (HI)	1728	484	959	1649	515	1027	1579	544	1089	1425	524	1138	1001	405	1168
ZY05 (4)	1 (LOW)	1299	223	786	1226	249	871	1137	273	956	1031	303	1051	923	329	1143
	2 (MED/LOW)	1413	272	832	1349	299	906	1266	325	982	1160	352	1070	1042	370	1155
	3 (MED)	1514	327	878	1456	353	942	1389	381	1014	1298	408	1089	1133	405	1165
	4 (MED/HI)	1751	472	972	1698	502	1033	1639	534	1088	1543	536	1142	1156	420	1172
	5 (HI)	2093	768	1116	1944	717	1137	1764	651	1152	1506	552	1163	1146	441	1177
ZY06 (5)	1 (LOW)	1528	328	781	1427	356	850	1346	386	912	1256	410	969	1181	434	1022
	2 (MED/LOW)	1575	362	803	1488	391	871	1401	419	929	1319	445	985	1247	469	1037
	3 (MED)	1867	572	902	1795	601	963	1709	628	1015	1633	652	1061	1544	671	1110
	4 (MED/HI)	2049	718	968	1969	768	1026	1902	788	1070	1808	802	1110	1637	744	1132
	5 (HI)	2218	899	1021	2138	928	1074	2007	907	1105	1846	842	1123	1671	767	1139

Table 17: ZY04-12 Bottom Duct Application (Belt Drive)

## ZY04 (3.0 Ton) Bottom Duct

CFM	Available External Static																					
	0.2		0.4		0.6		0.8		1.0		1.2		1.4		1.6		1.8		2.0			
	RPM	BHP	RPM	BHP	RPM	BHP	RPM	BHP	RPM	BHP	RPM	BHP	RPM	BHP	RPM	BHP	RPM	BHP	RPM	BHP		
900																						
1000	792	0.20	894	0.31	992	0.42	1087	0.52	1177	0.62	1263	0.72	1345	0.81	1422	0.90	1493	0.98	1560	1.05		
1100	810	0.26	912	0.37	1010	0.47	1104	0.58	1195	0.68	1281	0.77	1363	0.87	1439	0.95	1511	1.03	1577	1.11		
1200	829	0.32	931	0.43	1029	0.54	1124	0.64	1214	0.74	1300	0.84	1382	0.93	1459	1.02	1530	1.10	1593	1.17		
1300	850	0.39	952	0.50	1050	0.61	1145	0.71	1235	0.81	1321	0.91	1403	1.00	1480	1.09	1552	1.17	--	--		
1400	874	0.47	975	0.58	1073	0.69	1168	0.79	1258	0.89	1344	0.99	1426	1.08	1503	1.17	1575	1.25	--	--		
1500	899	0.56	1000	0.67	1098	0.77	1193	0.88	1283	0.98	1370	1.07	1451	1.17	1528	1.25	1600	1.33	--	--		

$$kW = 0.929 \times \text{BHP}$$

	Medium Static Option with Motor rated at 2.4-hp
	High Static Option with Motor rated at 2.9-hp
	Exceeds recommended blower speed

## ZY05 (4.0 Ton) Bottom Duct

CFM	Available External Static																					
	0.2		0.4		0.6		0.8		1.0		1.2		1.4		1.6		1.8		2.0			
	RPM	BHP	RPM	BHP	RPM	BHP	RPM	BHP	RPM	BHP	RPM	BHP	RPM	BHP	RPM	BHP	RPM	BHP	RPM	BHP		
1200	840	0.37	929	0.46	1016	0.56	1101	0.68	1184	0.80	1265	0.93	1345	1.04	1423	1.14	1500	1.22	1576	1.28		
1300	858	0.43	947	0.52	1035	0.62	1120	0.74	1203	0.86	1284	0.99	1364	1.10	1442	1.20	1519	1.28	1593	1.34		
1400	879	0.49	968	0.58	1055	0.69	1140	0.81	1224	0.93	1305	1.05	1385	1.17	1463	1.27	1540	1.35	--	--		
1500	903	0.56	992	0.65	1079	0.76	1164	0.88	1247	1.00	1328	1.12	1408	1.24	1486	1.34	1563	1.42	--	--		
1600	929	0.64	1018	0.73	1105	0.83	1190	0.95	1273	1.07	1354	1.20	1434	1.31	1512	1.41	1589	1.49	--	--		
1700	957	0.72	1047	0.81	1134	0.91	1219	1.03	1302	1.15	1383	1.28	1463	1.39	1541	1.49	--	--	--	--		
1800	989	0.80	1078	0.89	1165	1.00	1250	1.12	1333	1.24	1415	1.36	1494	1.47	1572	1.58	--	--	--	--		
1900	1023	0.89	1112	0.98	1199	1.08	1284	1.20	1367	1.33	1449	1.45	1528	1.56	--	--	--	--	--	--		
2000	1059	0.98	1149	1.07	1236	1.18	1321	1.29	1404	1.42	1485	1.54	1565	1.65	--	--	--	--	--	--		

$$kW = 0.929 \times \text{BHP}$$

	Medium Static Option with Motor rated at 2.4-hp
	High Static Option with Motor rated at 2.9-hp
	Exceeds recommended blower speed

## ZY06 (5.0 Ton) Bottom Duct

CFM	Available External Static																					
	0.2		0.4		0.6		0.8		1.0		1.2		1.4		1.6		1.8		2.0			
	RPM	BHP	RPM	BHP	RPM	BHP	RPM	BHP	RPM	BHP	RPM	BHP	RPM	BHP	RPM	BHP	RPM	BHP	RPM	BHP		
1500	840	0.48	910	0.58	977	0.67	1042	0.77	1106	0.87	1166	0.98	1225	1.08	1280	1.19	1334	1.30	1384	1.41		
1600	866	0.55	935	0.65	1003	0.74	1068	0.84	1131	0.94	1192	1.04	1250	1.15	1306	1.26	1359	1.37	1410	1.48		
1700	892	0.63	961	0.72	1029	0.82	1094	0.92	1157	1.02	1218	1.12	1276	1.23	1332	1.33	1385	1.44	1436	1.56		
1800	918	0.71	987	0.81	1055	0.90	1120	1.00	1183	1.10	1244	1.21	1302	1.31	1358	1.42	1411	1.53	1462	1.64		
1900	944	0.80	1014	0.90	1081	1.00	1146	1.09	1209	1.19	1270	1.30	1329	1.40	1384	1.51	1438	1.62	1488	1.73		
2000	971	0.90	1041	1.00	1108	1.09	1174	1.19	1237	1.29	1297	1.39	1356	1.50	1412	1.61	1465	1.72	1516	1.83		
2100	999	1.01	1069	1.10	1136	1.20	1202	1.30	1265	1.40	1326	1.50	1384	1.60	1440	1.71	1493	1.82	1544	1.93		
2200	1028	1.12	1098	1.21	1165	1.31	1231	1.41	1294	1.51	1355	1.61	1413	1.72	1469	1.82	1522	1.93	1573	2.05		
2300	1058	1.24	1128	1.33	1195	1.43	1261	1.53	1324	1.63	1385	1.73	1443	1.83	1499	1.94	1552	2.05	--	--		
2400	1090	1.36	1159	1.46	1227	1.55	1292	1.65	1355	1.75	1416	1.85	1474	1.96	1530	2.07	1583	2.18	--	--		
2500	1122	1.49	1191	1.59	1259	1.68	1324	1.78	1387	1.88	1448	1.98	1506	2.09	1562	2.20	1615	2.31	--	--		

	Medium Static Option with Motor rated at 2.4-hp
	High Static Option with Motor rated at 2.9-hp
	Exceeds recommended blower speed

**ZY07 (6.0 Ton) Bottom Duct**

CFM	Available External Static																			
	0.2		0.4		0.6		0.8		1.0		1.2		1.4		1.6		1.8		2.0	
	RPM	BHP	RPM	BHP	RPM	BHP	RPM	BHP	RPM	BHP	RPM	BHP	RPM	BHP	RPM	BHP	RPM	BHP	RPM	BHP
1800	525	0.31	590	0.48	653	0.65	713	0.82	770	0.98	825	1.15	878	1.31	928	1.48	976	1.65	1022	1.83
1900	534	0.36	599	0.53	661	0.71	721	0.87	779	1.03	834	1.20	886	1.36	936	1.53	984	1.70	1030	1.88
2000	542	0.41	607	0.59	670	0.76	730	0.93	787	1.09	842	1.25	895	1.42	945	1.58	993	1.75	1039	1.93
2100	551	0.47	616	0.65	678	0.82	738	0.99	796	1.15	850	1.31	903	1.47	953	1.64	1001	1.81	1047	1.99
2200	559	0.53	624	0.71	687	0.88	747	1.05	804	1.21	859	1.37	912	1.54	962	1.70	1010	1.88	1056	2.05
2300	568	0.60	634	0.78	696	0.95	756	1.11	813	1.28	868	1.44	921	1.60	971	1.77	1019	1.94	1065	2.12
2400	578	0.66	643	0.84	705	1.01	765	1.18	823	1.34	878	1.51	930	1.67	981	1.84	1029	2.01	1074	2.19
2500	588	0.74	653	0.91	715	1.08	775	1.25	833	1.41	888	1.58	940	1.74	991	1.91	1039	2.08	1084	2.26
2600	598	0.81	663	0.99	725	1.16	785	1.32	843	1.49	898	1.65	950	1.81	1001	1.98	1049	2.15	1094	2.33
2700	609	0.88	674	1.06	736	1.23	796	1.40	853	1.56	908	1.72	961	1.89	1011	2.05	1059	2.23	--	--
2800	620	0.96	685	1.14	747	1.31	807	1.47	864	1.64	919	1.80	972	1.96	1022	2.13	1070	2.30	--	--
2900	631	1.04	696	1.22	759	1.39	819	1.55	876	1.72	931	1.88	984	2.04	1034	2.21	1082	2.38	--	--
3000	643	1.12	708	1.30	771	1.47	830	1.64	888	1.80	943	1.96	996	2.12	1046	2.29	1094	2.46	--	--

Standard Static Option with Motor rated at 2.4-hp  
 Medium Static Option with Motor rated at 2.9-hp  
 High Static Option with Motor rated at 3.7-hp  
 Exceeds recommended blower speed

**ZYA7 (6.0 Ton) Bottom Duct**

CFM	Available External Static																			
	0.2		0.4		0.6		0.8		1.0		1.2		1.4		1.6		1.8		2.0	
	RPM	BHP	RPM	BHP	RPM	BHP	RPM	BHP	RPM	BHP	RPM	BHP	RPM	BHP	RPM	BHP	RPM	BHP	RPM	BHP
1800	525	0.31	590	0.48	653	0.65	713	0.82	770	0.98	825	1.15	878	1.31	928	1.48	976	1.65	1022	1.83
1900	534	0.36	599	0.53	661	0.71	721	0.87	779	1.03	834	1.20	886	1.36	936	1.53	984	1.70	1030	1.88
2000	542	0.41	607	0.59	670	0.76	730	0.93	787	1.09	842	1.25	895	1.42	945	1.58	993	1.75	1039	1.93
2100	551	0.47	616	0.65	678	0.82	738	0.99	796	1.15	850	1.31	903	1.47	953	1.64	1001	1.81	1047	1.99
2200	559	0.53	624	0.71	687	0.88	747	1.05	804	1.21	859	1.37	912	1.54	962	1.70	1010	1.88	1056	2.05
2300	568	0.60	634	0.78	696	0.95	756	1.11	813	1.28	868	1.44	921	1.60	971	1.77	1019	1.94	1065	2.12
2400	578	0.66	643	0.84	705	1.01	765	1.18	823	1.34	878	1.51	930	1.67	981	1.84	1029	2.01	1074	2.19
2500	588	0.74	653	0.91	715	1.08	775	1.25	833	1.41	888	1.58	940	1.74	991	1.91	1039	2.08	1084	2.26
2600	598	0.81	663	0.99	725	1.16	785	1.32	843	1.49	898	1.65	950	1.81	1001	1.98	1049	2.15	1094	2.33
2700	609	0.88	674	1.06	736	1.23	796	1.40	853	1.56	908	1.72	961	1.89	1011	2.05	1059	2.23	--	--
2800	620	0.96	685	1.14	747	1.31	807	1.47	864	1.64	919	1.80	972	1.96	1022	2.13	1070	2.30	--	--
2900	631	1.04	696	1.22	759	1.39	819	1.55	876	1.72	931	1.88	984	2.04	1034	2.21	1082	2.38	--	--
3000	643	1.12	708	1.30	771	1.47	830	1.64	888	1.80	943	1.96	996	2.12	1046	2.29	1094	2.46	--	--

Standard Static Option with Motor rated at 2.4-hp  
 Medium Static Option with Motor rated at 2.9-hp  
 High Static Option with Motor rated at 3.7-hp  
 Exceeds recommended blower speed

**ZY08 (7.5 Ton) Bottom Duct**

CFM	Available External Static																			
	0.2		0.4		0.6		0.8		1.0		1.2		1.4		1.6		1.8		2.0	
	RPM	BHP	RPM	BHP	RPM	BHP	RPM	BHP	RPM	BHP	RPM	BHP	RPM	BHP	RPM	BHP	RPM	BHP	RPM	BHP
2250	556	0.45	621	0.65	683	0.83	742	1.00	798	1.18	852	1.34	904	1.51	954	1.69	1003	1.87	1050	2.06
2400	567	0.53	632	0.73	694	0.91	753	1.09	809	1.26	863	1.43	914	1.60	964	1.77	1013	1.95	1060	2.14
2600	580	0.65	646	0.85	707	1.03	766	1.21	823	1.38	876	1.55	928	1.72	978	1.89	1027	2.07	1074	2.27
2800	595	0.79	660	0.99	722	1.17	780	1.35	837	1.52	890	1.69	942	1.86	992	2.03	1041	2.21	1088	2.40
3000	609	0.94	674	1.14	736	1.32	795	1.50	851	1.67	905	1.83	957	2.00	1007	2.18	1056	2.36	1100	2.55
3200	625	1.10	690	1.30	752	1.48	810	1.66	867	1.83	921	2.00	972	2.17	1022	2.34	1071	2.52	--	--
3400	641	1.28	706	1.47	768	1.66	827	1.83	883	2.00	937	2.17	989	2.34	1039	2.52	1087	2.70	--	--
3600	658	1.47	723	1.66	785	1.85	844	2.02	900	2.19	954	2.36	1006	2.53	1056	2.70	1100	2.89	--	--
3750	672	1.61	737	1.81	799	1.99	858	2.17	914	2.34	968	2.51	1019	2.68	1069	2.85	--	--	--	--

Standard Static Option with Motor rated at 2.4-hp  
 Medium Static Option with Motor rated at 2.4-hp  
 High Static Option with Motor rated at 3.7-hp  
 Exceeds recommended blower speed

## ZY09 (8.5 Ton) Bottom Duct

CFM	Available External Static																			
	0.2		0.4		0.6		0.8		1.0		1.2		1.4		1.6		1.8		2.0	
	RPM	BHP	RPM	BHP	RPM	BHP	RPM	BHP	RPM	BHP	RPM	BHP	RPM	BHP	RPM	BHP	RPM	BHP	RPM	BHP
2550	577	0.62	642	0.82	704	1.00	763	1.18	819	1.35	873	1.52	925	1.69	975	1.86	1023	2.04	1071	2.23
2600	580	0.65	646	0.85	707	1.03	766	1.21	823	1.38	876	1.55	928	1.72	978	1.89	1027	2.07	1074	2.27
2800	595	0.79	660	0.99	722	1.17	780	1.35	837	1.52	890	1.69	942	1.86	992	2.03	1041	2.21	1088	2.40
3000	609	0.94	674	1.14	736	1.32	795	1.50	851	1.67	905	1.83	957	2.00	1007	2.18	1056	2.36	1103	2.55
3200	625	1.10	690	1.30	752	1.48	810	1.66	867	1.83	921	2.00	972	2.17	1022	2.34	1071	2.52	--	--
3400	641	1.28	706	1.47	768	1.66	827	1.83	883	2.00	937	2.17	989	2.34	1039	2.52	1087	2.70	--	--
3600	658	1.47	723	1.66	785	1.85	844	2.02	900	2.19	954	2.36	1006	2.53	1056	2.70	1104	2.89	--	--
3800	676	1.67	742	1.86	803	2.04	862	2.22	918	2.39	972	2.56	1024	2.73	1074	2.90	--	--	--	--
4000	696	1.88	761	2.07	823	2.26	882	2.43	938	2.60	992	2.77	1043	2.94	1093	3.12	--	--	--	--
4200	716	2.10	781	2.29	843	2.48	902	2.65	958	2.82	1012	2.99	1064	3.16	1114	3.34	--	--	--	--
4250	721	2.16	786	2.35	848	2.53	907	2.71	963	2.88	1017	3.05	1069	3.22	1119	3.39	--	--	--	--

	Standard Static Option with Motor rated at 2.4-hp
	Medium Static Option with Motor rated at 2.4-hp
	High Static Option with Motor rated at 3.7-hp
	Field-supplied AK79 x 1 fixed pulley (p/n 9381) with Motor rated at 3.7-hp
--	Exceeds recommended blower speed

## ZY12 (10 Ton) Bottom Duct

CFM	Available External Static																			
	0.2		0.4		0.6		0.8		1.0		1.2		1.4		1.6		1.8		2.0	
	RPM	BHP	RPM	BHP	RPM	BHP	RPM	BHP	RPM	BHP	RPM	BHP	RPM	BHP	RPM	BHP	RPM	BHP	RPM	BHP
2600	626	0.50	679	0.73	731	0.97	782	1.20	831	1.44	880	1.67	928	1.90	976	2.12	1022	2.33	1068	2.53
2800	639	0.64	692	0.87	744	1.11	795	1.34	845	1.58	894	1.81	942	2.04	989	2.26	1036	2.47	1082	2.67
3000	653	0.79	706	1.02	758	1.25	808	1.49	858	1.72	907	1.95	955	2.18	1003	2.40	1049	2.62	1095	2.82
3200	667	0.94	720	1.17	771	1.40	822	1.64	872	1.88	921	2.11	969	2.34	1016	2.56	1063	2.77	1109	2.97
3400	682	1.11	734	1.34	786	1.57	837	1.81	887	2.04	936	2.28	984	2.50	1031	2.73	1078	2.94	1124	3.14
3600	697	1.29	750	1.52	802	1.76	853	1.99	903	2.23	952	2.46	1000	2.69	1047	2.91	1094	3.12	1140	3.32
3800	714	1.50	767	1.73	819	1.96	870	2.20	920	2.43	969	2.67	1017	2.90	1064	3.12	1111	3.33	1157	3.53
4000	733	1.73	786	1.96	837	2.19	888	2.43	938	2.66	987	2.90	1035	3.12	1083	3.34	1129	3.56	1175	3.76
4200	753	1.98	806	2.21	857	2.44	908	2.68	958	2.91	1007	3.15	1055	3.37	1102	3.60	1149	3.81	1195	4.01
4400	774	2.25	827	2.48	879	2.72	930	2.95	979	3.19	1028	3.42	1076	3.65	1124	3.87	1170	4.08	1216	4.28
4600	797	2.55	850	2.78	902	3.02	952	3.25	1002	3.49	1051	3.72	1099	3.95	1147	4.17	1193	4.38	1239	4.58
4800	822	2.88	874	3.11	926	3.34	977	3.58	1027	3.81	1076	4.05	1124	4.27	1171	4.50	1218	4.71	--	--
5000	848	3.23	901	3.46	952	3.69	1003	3.93	1053	4.16	1102	4.40	1150	4.62	1197	4.84	1242	5.06	--	--

	Standard Static Option with Motor rated at 2.4-hp
	Medium Static Option with Motor rated at 3.7-hp
	High Static Option with Motor rated at 5.25-hp
-	Exceeds recommended blower speed

**Table 18: ZY04-06 Bottom Duct Application (Direct Drive)**

**ZY04-06 Bottom Duct (Cooling)**

Unit (Ton)	Motor Speed	Available External Static														
		0.2			0.4			0.6			0.8			1.0		
		CFM	WATTS	RPM	CFM	WATTS	RPM	CFM	WATTS	RPM	CFM	WATTS	RPM	CFM	WATTS	RPM
ZY04 (3)	1 (LOW)	929	128	699	782	148	794	663	164	880	514	187	976	377	202	1053
	2 (MED/LOW)	1036	157	732	870	177	827	803	198	905	649	217	996	508	236	1074
	3 (MED)	1106	181	760	956	204	849	878	225	928	755	245	1010	616	266	1092
	4 (MED/HI)	1147	197	776	1042	218	860	916	243	944	820	262	1017	671	286	1103
	5 (HI)	1272	252	830	1177	277	909	1037	304	986	975	323	1053	872	347	1125
ZY05 (4)	1 (LOW)	1256	220	776	1170	242	851	1077	266	931	988	298	1025	872	321	1113
	2 (MED/LOW)	1350	272	828	1279	292	893	1196	320	966	1105	347	1048	1003	372	1131
	3 (MED)	1449	323	866	1380	350	937	1303	370	996	1223	402	1071	1133	428	1149
	4 (MED/HI)	1488	345	882	1418	374	954	1357	394	1006	1264	424	1083	1160	442	1155
	5 (HI)	1677	471	966	1602	507	1034	1543	525	1083	1475	545	1131	1209	465	1162
ZY06 (5)	1 (LOW)	1548	310	720	1441	336	792	1337	370	864	1213	397	928	1097	421	988
	2 (MED/LOW)	1593	337	738	1488	363	805	1381	394	875	1271	425	937	1150	451	997
	3 (MED)	1880	532	827	1792	563	890	1719	588	944	1632	629	1006	1527	652	1061
	4 (MED/HI)	2066	689	895	1999	712	942	1907	761	999	1830	773	1048	1734	809	1100
	5 (HI)	2237	862	949	2163	882	996	2097	929	1036	1998	946	1085	1815	883	1115

**ZY04-06 Bottom Duct (Gas Heat)**

Unit (Ton)	Motor Speed	Available External Static														
		0.2			0.4			0.6			0.8			1.0		
		CFM	WATTS	RPM	CFM	WATTS	RPM	CFM	WATTS	RPM	CFM	WATTS	RPM	CFM	WATTS	RPM
ZY04 (3)	1 (LOW)	969	130	703	839	151	810	717	174	916	569	191	1006	444	204	1069
	2 (MED/LOW)	1063	158	741	955	180	834	828	204	938	709	227	1030	583	242	1100
	3 (MED)	1135	182	769	1041	208	858	919	229	952	805	254	1045	681	275	1127
	4 (MED/HI)	1310	256	842	1225	279	917	1123	307	1001	1029	334	1083	863	335	1155
	5 (HI)	1680	501	997	1622	526	1056	1538	546	1119	1296	485	1153	939	374	1176
ZY05 (4)	1 (LOW)	1277	228	801	1196	251	878	1096	278	967	983	305	1062	873	329	1156
	2 (MED/LOW)	1382	278	847	1307	302	916	1217	327	994	1108	355	1083	949	359	1164
	3 (MED)	1486	331	888	1417	359	957	1331	385	1028	1237	410	1103	1023	385	1169
	4 (MED/HI)	1717	473	991	1653	509	1052	1586	538	1107	1443	521	1150	1052	394	1175
	5 (HI)	2006	738	1132	1854	682	1147	1704	621	1154	1504	552	1168	1073	418	1177
ZY06 (5)	1 (LOW)	1488	335	787	1400	363	851	1320	389	910	1242	416	969	1160	440	1027
	2 (MED/LOW)	1536	364	803	1453	392	864	1363	419	924	1293	447	981	1212	471	1037
	3 (MED)	1822	586	914	1752	602	966	1666	632	1017	1586	656	1066	1503	676	1113
	4 (MED/HI)	1999	726	982	1932	761	1030	1860	809	1076	1753	799	1114	1598	749	1134
	5 (HI)	2170	932	1040	2091	930	1084	1965	910	1109	1798	843	1127	1618	763	1139

Table 19: RPM Selection

Model	Size (Tons)	Airflow Option	Phase	MAX BHP	Blower Sheave	Motor Sheave	6Turns Open	5Turns Open	4Turns Open	3 Turns Open	2 Turns Open	1 Turn Open	Fully Closed
ZY	04 (3)	Std.	Direct Drive										
		Med.	1	1.5	AK46	1VL34	N/A	792	875	958	1042	1125	1208
		Med.	3	2.4	AK46	1VL34	N/A	792	875	958	1042	1125	1208
		H. Static	3	2.4	AK46	1VL44	N/A	1167	1250	1333	1417	1500	1593
ZY	05 (4)	Std.	Direct Drive										
		Med.	1	1.5	AK46	1VL34	N/A	792	875	958	1042	1125	1208
		Med.	3	2.4	AK46	1VL34	N/A	792	875	958	1042	1125	1208
		H. Static	3	2.9	AK46	1VL44	N/A	1167	1250	1333	1417	1500	1593
ZY	06 (5)	Std.	Direct Drive										
		Med.	1	1.5	AK46	1VL34	N/A	792	875	958	1042	1125	1208
		Med.	3	2.4	AK46	1VL34	N/A	792	875	958	1042	1125	1208
		H. Static	3	2.9	AK46	1VL44	N/A	1167	1250	1333	1417	1500	1593
ZY	07 (6)	Std.	3	2.4	AK74	1VL34	N/A	475	525	575	625	675	725
		Med.	3	2.9	AK74	1VL44	N/A	700	750	800	850	900	950
		H. Static	3	3.7	AK74	1VP50	N/A	850	900	950	1000	1050	1100
ZY	A7 (6)	Std.	3	2.4	AK74	1VL34	N/A	475	525	575	625	675	725
		Med.	3	2.9	AK74	1VL44	N/A	700	750	800	850	900	950
		H. Static	3	3.7	AK74	1VP50	N/A	850	900	950	1000	1050	1100
ZY	08 (7.5)	Std.	3	2.4	AK74	1VL34	N/A	475	525	575	625	675	725
		Med.	3	2.4	AK74	1VL44	N/A	700	750	800	850	900	950
		H. Static	3	3.7	AK74	1VP50	N/A	850	900	950	1000	1050	1100
ZY	9 (8.5)	Std.	3	2.4	AK74	1VL34	N/A	475	525	575	625	675	725
		Med.	3	2.4	AK74	1VL44	N/A	700	750	800	850	900	950
		H. Static	3	3.7	AK74	1VP50	N/A	850	900	950	1000	1050	1100
ZY	12 (10)	Std.	3	2.4	AK79	1VL44	N/A	653	700	747	793	840	887
		Med.	3	3.7	AK79	1VP50	N/A	793	840	887	933	980	1027
		H. Static	3	5.25	BK85	1VP56	953	997	1041	1085	1130	1174	N/A

Table 20: Indoor Blower Specifications

Model	Size (Tons)	Airflow Option	Motor						Motor Sheave			Blower Sheave			Belt
			Phase	MAX BHP	RPM	Eff.	SF	Frame	Datum Dia. (in.)	Bore (in.)	Model	Datum Dia. (in.)	Bore (in.)	Model	
ZY	04 (3)	Std.	Direct Drive												
		Med.	1	1.5	1725	0.79	1.15	56HZ	1.9 - 2.9	5/8	1VL34	4.2	3/4	AK46	A39
		Med.	3	2.4	1725	0.80	1.15	56Y	1.9 - 2.9	5/8	1VL34	4.2	3/4	AK46	A39
		H. Static	3	2.4	1725	0.80	1.15	56Y	2.8 - 3.8	5/8	1VL44	4.2	3/4	AK46	A40
ZY	05 (4)	Std.	Direct Drive												
		Med.	1	1.5	1725	0.79	1.15	56HZ	1.9 - 2.9	5/8	1VL34	4.2	3/4	AK46	A39
		Med.	3	2.4	1725	0.80	1.15	56Y	1.9 - 2.9	5/8	1VL34	4.2	3/4	AK46	A39
		H. Static	3	2.9	1725	0.81	1.15	56Y	2.8 - 3.8	7/8	1VL44	4.2	3/4	AK46	A40
ZY	06 (5)	Std.	Direct Drive												
		Med.	1	1.5	1750	0.83	1.15	56H	1.9 - 2.9	5/8	1VL34	4.2	3/4	AK46	A37
		Med.	3	2.4	1750	0.87	1.15	56HZ	1.9 - 2.9	5/8	1VL34	4.2	3/4	AK46	A37
		H. Static	3	2.9	1750	0.87	1.15	56Z	2.8 - 3.8	7/8	1VL44	4.2	3/4	AK46	A39
ZY	07 (6)	Std.	3	2.4	1725	0.80	1.15	56Y	1.9 - 2.9	5/8	1VL34	7.0	1	AK74	A47
		Med.	3	2.9	1725	0.81	1.15	56Y	2.8 - 3.8	7/8	1VL44	7.0	1	AK74	A48
		H. Static	3	3.7	1725	0.84	1.15	56HZ	3.4 - 4.4	7/8	1VP50	7.0	1	AK74	A48
ZY	A7 (6)	Std.	3	2.4	1725	0.80	1.15	56Y	1.9 - 2.9	5/8	1VL34	7.0	1	AK74	A47
		Med.	3	2.9	1725	0.81	1.15	56Y	2.8 - 3.8	7/8	1VL44	7.0	1	AK74	A48
		H. Static	3	3.7	1725	0.84	1.15	56HZ	3.4 - 4.4	7/8	1VP50	7.0	1	AK74	A48
ZY	08 (7.5)	Std.	3	2.4	1725	0.80	1.15	56Y	1.9 - 2.9	5/8	1VL34	7.0	1	AK74	A47
		Med.	3	2.4	1725	0.80	1.15	56Y	2.8 - 3.8	5/8	1VL44	7.0	1	AK74	A48
		H. Static	3	3.7	1725	0.84	1.15	56HZ	3.4 - 4.4	7/8	1VP50	7.0	1	AK74	A50
ZY	09 (8.5)	Std.	3	2.4	1725	0.80	1.15	56Y	1.9 - 2.9	5/8	1VL34	7.0	1	AK74	A47
		Med.	3	2.4	1725	0.80	1.15	56Y	2.8 - 3.8	5/8	1VL44	7.0	1	AK74	A48
		H. Static	3	3.7	1725	0.84	1.15	56HZ	3.4 - 4.4	7/8	1VP50	7.0	1	AK74	A50
ZY	12 (10)	Std.	3	2.4	1725	0.80	1.15	56Y	2.8 - 3.8	5/8	1VL44	7.5	1	AK79	A50
		Med.	3	3.7	1725	0.84	1.15	56HZ	3.4 - 4.4	7/8	1VP50	7.5	1	AK79	A50
		H. Static	3	5.25	1725	0.84	1.15	145TY	4.3 - 5.3	7/8	1VP56	7.9	1	BK85	BX52

**Supply Air Drive Adjustment**

**CAUTION**

Before making any blower speed changes review the installation for any installation errors, leaks or undesirable systems effects that can result in loss of airflow.

Even small changes in blower speed can result in substantial changes in static pressure and BHP. BHP and AMP draw of the blower motor will increase by the cube of the blower speed. Static pressure will increase by the square of the blower speed. Only qualified personnel should make blower speed changes, strictly adhering to the fan laws.

At unit start-up, the measured CFM may be higher or lower than the required CFM. To achieve the required CFM, the speed of the drive may have adjusted by changing the datum diameter (DD) of the variable pitch motor sheave as described below:

$$\left( \frac{\text{Required CFM}}{\text{Measured CFM}} \right) \cdot \text{Existing DD} = \text{New DD}$$

Use the following tables and the DD calculated per the above equation to adjust the motor variable pitch sheave.

**EXAMPLE NEW DATUM DIAMETER**

A 4 ton unit was selected to deliver 1,600 CFM with a 1VL34 motor sheave, but the unit is delivering 1,350 CFM. The variable pitch motor sheave is set at 4 turns open.

Use the equation to determine the required DD for the new motor sheave,

$$\left( \frac{1,600 \text{ CFM}}{1,350 \text{ CFM}} \right) \cdot 2.1 \text{ in.} = 2.48 \text{ in.}$$

Use Table 21 to locate the DD nearest to 2.48 in. Close the sheave to 2 turn open.

**EXAMPLE NEW BHP**

$$= (\text{Speed increase})^3 \cdot \text{Original BHP} = \text{New BHP}$$

$$= (\text{Speed increase})^3 \cdot \text{BHP at 1,350 CFM}$$

**EXAMPLE NEW MOTOR AMPS**

$$= (\text{Speed increase})^3 \cdot \text{Original Amps} = \text{New Amps}$$

$$= (\text{Speed increase})^3 \cdot \text{Amps at 1,350 CFM}$$

**Table 21: Motor Sheave Datum Diameters**

1VL34		1VL44		1VP50		1VP56	
Turns Open	Datum Diameter	Turns Open	Datum Diameter	Turns Open	Datum Diameter	Turns Open	Datum Diameter
0	2.9	0	3.8	0	4.4	0	-
1/2	2.8	1/2	3.7	1/2	4.3	1/2	-
1	2.7	1	3.6	1	4.2	1	5.3
1-1/2	2.6	1-1/2	3.5	1-1/2	4.1	1-1/2	5.2
2	2.5	2	3.4	2	4.0	2	5.1
2-1/2	2.4	2-1/2	3.3	2-1/2	3.9	2-1/2	5.0
3	2.3	3	3.2	3	3.8	3	4.9
3-1/2	2.2	3-1/2	3.1	3-1/2	3.7	3-1/2	4.8
4	2.1	4	3.0	4	3.6	4	4.7
4-1/2	2.0	4-1/2	2.9	4-1/2	3.5	4-1/2	4.6
5	1.9	5	2.8	5	3.4	5	4.5
5-1/2	-	5-1/2	-	5-1/2	-	5-1/2	4.4
6	-	6	-	6	-	6	4.3

**CAUTION**

Belt drive blower systems MUST be adjusted to the specific static and CFM requirements for the application. The Belt drive blowers are NOT set at the factory for any specific static or CFM. Adjustments of the blower speed and belt tension are REQUIRED. Verify proper sheave alignment; tighten blower pulley and motor sheave set screws after these adjustments. Re-checking set screws and belt tension after 10-12 hrs. run time is recommended.



Table 22: Additional Static Resistance - ZY04-12

Model	Size (Tons)	CFM	Cooling Only <sup>1</sup>	Economizer <sup>2 3</sup>	4" Filters <sup>2</sup>	Electric Heat kW <sup>2</sup>							
						6/6.5	9.2/10.5/11	13.8/14/16	16/16.5/17	23	24.8/25.5/27.8	32/33/34	41.7/42.4
ZY	04 (3.0)	900	0.04	0.05	---	0.00	0.00	0.01	---	0.01	---	---	---
		1000	0.05	0.05	---	0.00	0.00	0.02	---	0.02	---	---	---
		1100	0.06	0.06	---	0.01	0.01	0.02	---	0.03	---	---	---
		1200	0.07	0.06	---	0.01	0.01	0.02	---	0.03	---	---	---
		1300	0.10	0.07	---	0.01	0.01	0.03	---	0.03	---	---	---
		1400	0.12	0.08	---	0.02	0.02	0.03	---	0.04	---	---	---
		1500	0.14	0.08	---	0.02	0.02	0.04	---	0.04	---	---	---
	05 (4.0)	1200	0.06	0.06	---	0.01	0.01	0.02	---	0.03	---	---	---
		1300	0.06	0.07	---	0.01	0.01	0.03	---	0.03	---	---	---
		1400	0.06	0.08	---	0.02	0.02	0.03	---	0.04	---	---	---
		1500	0.07	0.08	---	0.02	0.02	0.04	---	0.04	---	---	---
		1600	0.08	0.09	---	0.02	0.02	0.04	---	0.05	---	---	---
		1700	0.11	0.10	---	0.03	0.03	0.05	---	0.05	---	---	---
		1800	0.13	0.11	---	0.03	0.03	0.05	---	0.06	---	---	---
		1900	0.16	0.12	---	0.04	0.04	0.06	---	0.07	---	---	---
	06 (5.0)	2000	0.20	0.13	---	0.04	0.04	0.07	---	0.08	---	---	---
		1800	0.23	0.11	---	0.03	0.03	0.05	---	0.06	---	---	---
		2000	0.28	0.13	---	0.04	0.04	0.07	---	0.08	---	---	---
		2200	0.32	0.15	---	0.06	0.06	0.08	---	0.09	---	---	---
		2400	0.37	0.17	---	0.07	0.07	0.10	---	0.11	---	---	---
	07 (6.0)	2500	0.50	0.19	---	0.08	0.08	0.11	---	0.12	---	---	---
		1800	0.23	0.11	---	0.03	---	---	0.05	---	0.06	---	---
		2000	0.28	0.13	---	0.04	---	---	0.06	---	0.07	---	---
		2200	0.32	0.15	---	0.06	---	---	0.07	---	0.09	---	---
		2400	0.37	0.17	---	0.07	---	---	0.08	---	0.1	---	---
		2600	0.38	0.20	---	0.08	---	---	0.09	---	0.11	---	---
		2800	0.41	0.24	---	0.09	---	---	0.10	---	0.12	---	---
	A7 (6.0)	3000	0.45	0.29	---	0.11	---	---	0.12	---	0.14	---	---
		1800	0.23	0.11	---	0.03	---	---	0.05	---	0.06	---	---
		2000	0.28	0.13	---	0.04	---	---	0.06	---	0.07	---	---
		2200	0.32	0.15	---	0.06	---	---	0.07	---	0.09	---	---
		2400	0.37	0.17	---	0.07	---	---	0.08	---	0.1	---	---
		2600	0.38	0.20	---	0.08	---	---	0.09	---	0.11	---	---
		2800	0.41	0.24	---	0.09	---	---	0.10	---	0.12	---	---
	08 (7.5), 09 (8.5), 12 (10.0)	3000	0.45	0.29	---	0.11	---	---	0.12	---	0.14	---	---
		2200	0.04	0.11	---	---	---	---	0.07	---	0.09	0.10	0.12
		2600	0.06	0.13	---	---	---	---	0.09	---	0.11	0.12	0.15
		3000	0.10	0.17	---	---	---	---	0.12	---	0.14	0.15	0.19
		3400	0.13	0.20	---	---	---	---	0.15	---	0.18	0.19	0.23
		3800	0.16	0.25	---	---	---	---	0.19	---	0.22	0.23	0.27
		4000	0.17	0.28	---	---	---	---	0.21	---	0.24	0.25	0.30
		4400	0.20	0.33	---	---	---	---	0.25	---	0.29	0.30	0.35
		4800	0.22	0.38	---	---	---	---	0.30	---	0.34	0.35	0.41
		5200	0.24	0.43	---	---	---	---	0.35	---	0.39	0.41	0.47
	5600	0.26	0.46	---	---	---	---	0.41	---	0.45	0.47	0.54	
	6000	0.28	0.50	---	---	---	---	0.48	---	0.52	0.54	0.60	

1. Add these values to the available static resistance in the respective Blower Performance Tables.
2. Deduct these values from the available external static pressure shown in the respective Blower Performance Tables.
3. The pressure drop through the economizer is greater for 100% outdoor air than for 100% return air. If the resistance of the return air duct is less than 0.25 IWG, the unit will deliver less CFM during full economizer operation.



Figure 24: Unit Control Board

Table 23: Smart Equipment™ UCB Details

Description		Function & Comments
<b>Terminal Directional orientation: viewed with silkscreen labels upright</b>		
<b>Limit, 24 VAC power and shutdown connections from unit wiring harness at left on upper edge of UCB</b>		
<b>LIMIT</b>	Monitored 24 VAC input through heat section limit switch(es)	If voltage is absent, indicating the heat section is over-temperature, the UCB will bring on the indoor blower
<b>C</b>	24 VAC, 75 VA transformer Common referenced to cabinet ground	Connects through circuit traces to thermostat connection strip C and indoor blower VFD pin C
<b>24V</b>	24 VAC, 75 VA transformer hot	Powers the UCB microprocessor, connects through circuit trace to the SD 24 terminal
<b>SD 24</b>	24 VAC hot out for factory accessory smoke detector, condensate overflow and/or user shutdown relay switching in series	Connects through circuit trace to thermostat connection strip SD-24. A wiring harness jumper plug connecting SD 24 to SD R is in place if factory accessories for unit shutdown are not used - this jumper plug must be removed if the switching of field-added external accessories for unit shutdown are wired between thermostat connection strip SD-24 and R
<b>SD R</b>	24 VAC hot return from factory accessory smoke detector, condensate overflow and user shutdown relay switching in series	Connects through circuit trace to the R terminal on the upper left of the board
<b>R</b>	24 VAC hot for switched inputs to the UCB	Connects through circuit trace to the thermostat connection strip R terminal, right FAN OVR pin, right HPS1 pin, right HPS2 pin, lower DFS pin and lower APS pin

Table 23: Smart Equipment™ UCB Details (Continued)

Description		Function & Comments
<b>Terminal Thermostat connection strip on left edge of UCB</b>		
<b>W1</b>	1st stage heating request, 24 VAC input switched from R	Not effective for cooling-only units
<b>W2</b>	2nd stage heating request, 24 VAC input switched from R	Not effective for cooling-only units or units with single-stage heat sections
<b>Y1</b>	1st stage cooling request, 24 VAC input switched from R	
<b>Y2</b>	2nd stage cooling request, 24 VAC input switched from R	Visible in the display menu when the #ClgStgs parameter is set for 2 or more, also effective for economizer free cooling supply air temperature reset when the #ClgStgs parameter is set for 1 or more
<b>G</b>	Continuous indoor blower request, 24 VAC input switched from R	
<b>OCC</b>	Occupancy request, 24 VAC input switched from R	Must have the OccMode parameter set for External to be effective
<b>X</b>	Hard lockout indicator, 24 volt output to a light thermostat LED	
<b>R</b>	24 VAC hot for thermostat switching and power	If field-added external accessories for unit shutdown are used, 24 VAC hot return from smoke detector, condensate overflow and/or user shutdown relay switching in series
<b>SD-24</b>	If field-added external accessories for unit shutdown are used, 24 VAC hot out for smoke detector, condensate over- flow and/or user shutdown relay switching in series	Unit wiring harness jumper plug for factory shutdown accessories must be removed if the switching of field-added external accessories for unit shutdown are wired between thermo- stat connection strip SD-24 and R
<b>C</b>	24 VAC common for thermostat power	
<b>LEDs on left edge of UCB</b>		
<b>POWER</b>	Green UCB power indicator	Lit indicates 24 VAC is present at C and 24V terminals
<b>FAULT</b>	Red hard lockout, networking error and firmware error indicator	1/2 second on/off flashing indicates one or more alarm is currently active, 1/10th second on/off flashing indicates a networking error (polarity, addressing, etc.) or a firmware error (likely correctable with re-loading from USB flash drive)
<b>SA BUS</b>	Green UCB SA bus communication transmission indicator	Lit/flickering indicates UCB SA bus communication is currently active, off indicates the UCB is awaiting SA bus communication
<b>Terminal Space temperature sensor connections at center on upper edge of UCB</b>		
<b>ST</b>	Space Temperature sensor input from 10KΩ @ 77°F, Type III negative temperature coefficient thermistor	Positive of VDC circuit (3.625 VDC reading to COM with open circuit), effective if "Thermo- stat-only Control" parameter is set OFF, space sensor override momentary shorts ST to COM to initiate/terminate temporary occupancy
<b>COM</b>	Common for ST and SSO inputs	Negative of VDC circuit for ST and SSO inputs
<b>SSO</b>	Space Sensor Offset input from 0 to 20KΩ potentiometer	Positive of VDC circuit (3.625 VDC reading to COM with open circuit), 10KΩ/2.5 VDC is 0°F offset, 0Ω/0 VDC is maximum above offset and 20KΩ/3.4 VDC is maximum below offset from active space temperature setpoint
<b>Pin Temperature sensor connections at right on upper edge of UCB</b>		
<b>SAT+</b>	Supply Air Temperature sensor input from 10KΩ @ 77°F, Type III negative temperature coefficient thermistor	Input required for operation; 3.625 VDC reading SAT+ to SAT- with open circuit. Used in heat/cool staging cutouts, free cooling operation, demand ventilation operation, comfort ventilation operation, economizer loading operation, VAV cooling operation, hydronic heat operation.

**Table 23: Smart Equipment™ UCB Details (Continued)**

Description		Function & Comments
<b>RAT+</b>	Return Air Temperature sensor input from 10KΩ @ 77°F, Type III negative temperature coefficient thermistor	Input required for operation; 3.625 VDC reading RAT+ to RAT– with open circuit. Used in return air enthalpy calculation. Substitutes for space temperature if no other space temperature input is present.
<b>OAT+</b>	Outside Air Temperature sensor input from 10KΩ @ 77°F, Type III negative temperature coefficient thermistor	Input required for operation but may be a communicated value; 3.625 VDC reading OAT+ to OAT– with open circuit. Used in heat/cool cutouts, low ambient cooling determination, dry bulb free cooling changeover, outside air enthalpy calculation, economizer loading operation, heat pump demand defrost calculation.
<b>CC1+</b>	#1 refrigerant circuit Condenser Coil temperature sensor input from 10KΩ @ 77°F, Type III negative temperature coefficient thermistor	Input required for heat pump units, not required for A/C units; 3.625 VDC reading CC1+ to CC1– with open circuit. Used in heat pump demand defrost calculation.
<b>EC1+</b>	#1 refrigerant circuit Evaporator Coil temperature sensor input from 10KΩ @ 77°F, Type III negative temperature coefficient thermistor	Input required for operation; 3.625 VDC reading EC1+ to EC1– with open circuit. Used in suction line temperature safety.
<b>CC2+</b>	#2 refrigerant circuit Condenser Coil temperature sensor input from 10KΩ @ 77°F, Type III negative temperature coefficient thermistor	Input required for 2-compressor heat pump units, not required for 2-compressor A/C units, not active for 1-compressor units; 3.625 VDC reading CC2+ to CC2– with open circuit. Used in heat pump demand defrost calculation.
<b>EC2+</b>	#2 refrigerant circuit Evaporator Coil temperature sensor input from 10KΩ @ 77°F, Type III negative temperature coefficient thermistor	Input required for operation of 2-compressor units, not active for 1-compressor units; 3.625 VDC reading EC2+ to EC2– with open circuit. Used in suction line temperature safety.
<b>Pinned connections on right edge of UCB</b>		
<b>RAH+</b>	Return Air Humidity input from 0-10 VDC @ 0-100% RH sensor	Input required for reheat units, optional in all other units, may be a communicated value. Used in return air enthalpy calculation, temperature/humidity setpoint reset, reheat operation.
<b>DCT PRS+</b>	Supply Duct Pressure input from 0-5 VDC @ 0-5" w.c. sensor	Input required for variable air volume units. Used in VAV indoor blower operation.
<b>DFS (upper pin)</b>	24 VAC hot return from Dirty Filter Switch	Optional input; switch closure for greater than 15 seconds during indoor blower operation initiates a notification alarm
<b>DFS (lower pin)</b>	24 VAC hot out for Dirty Filter Switch	Connects through circuit trace to the R terminal
<b>APS (upper pin)</b>	24 VAC hot return from Air Proving Switch	When this optional input is enabled: the air proving switch must close within 30 seconds of initiation of indoor blower operation and not open for greater than 10 seconds during in-door blower operation to allow heat/cool operation and prevent an "APS open" alarm; the air proving switch must open within 30 seconds of termination of indoor blower operation to prevent an "APS stuck closed" notification alarm
<b>APS (lower pin)</b>	24 VAC hot out for Air Proving Switch	Connects through circuit trace to the R terminal
<b>C</b>	Common for the VFD output	Negative of the VDC circuit for the VFD output
<b>VFD</b>	2-10 VDC (0-100%) output for the indoor blower Variable Frequency Drive	Output is active with indoor blower operation. For CV units: this output provides stepped IntelliSpeed control of the indoor blower VFD based on fan-only, cooling stage and heating stage outputs. For VAV units: this output provides control of the indoor blower VFD based on supply duct static pressure input and setpoint.
<b>VFDFLT</b>	24 VAC hot input from the normally open VFD alarm contact	The VFD alarm contact switches from R within the unit wiring harness. 24 VAC input results in unit shutdown and a "VFD fault" alarm

Table 23: Smart Equipment™ UCB Details (Continued)

Description	Function & Comments
<b>Terminal at lower right corner of UCB</b>	
<b>24V FOR OUTPUTS</b>	24 VAC hot for H1, H2, CN-FAN, AUX HGR, FAN C1 and C2 output relay contact switching Output relay circuitry is isolated from other UCB components and the 24 VAC hot source may be from a second transformer in the unit
<b>Pin Heat section connections at right on lower edge of UCB</b>	
<b>H1</b>	24 VAC hot output for heat section stage 1 Not effective for cooling-only units. Output if demand is present and permissions allow one stage or two stages of heat section operation
<b>H2</b>	24 VAC hot output for heat section stage 2 Not effective for cooling-only units or units with single-stage heat sections. Output if demand is present and permissions allow two stages of heat section operation
<b>MV</b>	24 VAC hot input confirming heat section operation Sourced from gas valve in gas heat units or first stage heat contactor in electric heat units. Input within 5 minutes from initiation of H1 output initiates the "Heat On Fan Delay" timer, loss of input following the termination of H1 output initiates the "Heat On Fan Delay" timer, no input within 5 minutes from initiation of H1 output initiates an "Ignition Failure" alarm, input for longer than 5 minutes without H1 output initiates a "Gas Valve Mis-wire" alarm
<b>Pin Cooling and fan output connections at right on lower edge of UCB</b>	
<b>CN-FAN</b>	24 VAC hot output for the condenser fan contactor coil Output with either C1 or C2 output; interrupted during defrost cycle for heat pump units
<b>AUX HGR</b>	24 VAC hot output for hot gas reheat components Effective only for reheat units, output with reheat operation
<b>FAN</b>	24 VAC hot output for indoor blower contactor coil/indoor blower VFD enable relay coil Output with heat/cool operation, G input or schedule demand
<b>C1</b>	24 VAC hot output for compressor 1 If demand is present and permissions allow compressor 1 operation; output with compressor cooling, comfort ventilation cooling, reheat or heat pump heating demands
<b>C2</b>	24 VAC hot output for compressor 2 Not effective for one stage compressor UCBs. If demand is present and permissions allow compressor 2 operation; output with compressor cooling, comfort ventilation cooling or heat pump heating demands
<b>Pin Refrigerant circuit safety switch and indoor blower overload connections at center on lower edge of UCB</b>	
<b>HPS1 (right pin)</b>	24 VAC hot out for refrigerant circuit 1 High Pressure Switch Connects through circuit trace to the R terminal
<b>HPS1 (left pin)</b>	24 VAC hot return from refrigerant circuit 1 High Pressure Switch Input is only considered if C1 output is needed; input must be present to allow C1 output. Three HPS1 trips in a two hour period cause a "High Pressure Switch 1 Lockout" and C1 output is then prevented until alarm reset. Connects through circuit trace to the right LPS1 pin.
<b>LPS1 (right pin)</b>	24 VAC hot out for refrigerant circuit 1 Low Pressure Switch Connects through circuit trace to the left HSP1 pin
<b>LPS1 (left pin)</b>	24 VAC hot return from refrigerant circuit 1 Low Pressure Switch Input is only considered after 30 seconds of C1 output; afterwards, input must be present to allow C1 output. Three LPS1 trips in a one hour period cause a "Low Pressure Switch 1 Lockout" and C1 output is then prevented until alarm reset.
<b>HPS2 (right pin)</b>	24 VAC hot out for refrigerant circuit 2 High Pressure Switch Not effective for one stage compressor UCBs. Connects through circuit trace to the R terminal

**Table 23: Smart Equipment™ UCB Details (Continued)**

Description		Function & Comments
<b>HPS2 (left pin)</b>	24 VAC hot return from refrigerant circuit 2 High Pressure Switch	Not effective for one stage compressor UCBs. Input is only considered if C2 output is needed; input must be present to allow C1 output. Three HPS2 trips in a two hour period cause a "High Pressure Switch 1 Lockout" and C2 output is then prevented until alarm reset. Connects through circuit trace to the right LPS2 pin.
<b>LPS2 (right pin)</b>	24 VAC hot out for refrigerant circuit 2 Low Pressure Switch	Not effective for one stage compressor UCBs. Connects through circuit trace to the left HSP2 pin
<b>LPS2 (left pin)</b>	24 VAC hot return from refrigerant circuit 2 Low Pressure Switch	Not effective for one stage compressor UCBs. Input is only considered after 30 seconds of C2 output; afterwards, input must be present to allow C2 output. Three LPS2 trips in a one hour period cause a "Low Pressure Switch 2 Lockout" and C2 output is then prevented until alarm reset.
<b>FAN OVR (right pin)</b>	24 VAC hot out for indoor blower FAN Overload relay contact/motor protector switch	Connects through circuit trace to the R terminal
<b>FAN OVR (left pin)</b>	24 VAC hot return from indoor blower FAN Overload relay contact/motor protector switch	Input is only considered if FAN output is needed; input must be present to allow FAN output and unit operation. One FAN OVR trip lasting longer than 5 minutes or three FAN OVR trips in a two hour period cause a "Fan Overload Lockout" and unit operation is then prevented until alarm reset.
<b>Terminal SA BUS<sup>1</sup> connections on at left on lower edge and center of UCB</b>		
<b>PWR</b>	Power for SA ("Sensor-Actuator") BUS devices	Also incorporated in the J8 6-pin phone jack connector at the left-center of the board. Positive of the 15 VDC (reading to C) circuit for powering an optional netstat and/or Multi Touch gateway
<b>C</b>	Common for SA BUS power and communication circuits	Also incorporated in the J8 6-pin phone jack connector at the left-center of the board. Negative of the SA BUS circuits
<b>-</b>	Communication for SA BUS devices	Also incorporated in the J8 6-pin phone jack connector at the left-center of the board. Positive of the VDC (typically, a fluctuating 1.5 to 3.5 volts reading to C; at least 0.25 volts lower than +) SA BUS communication circuit to optional economizer board, 4-stage board, fault detection & diagnostics board, netstat and/or Multi Touch gateway
<b>+</b>	Communication for SA BUS devices	Also incorporated in the J8 6-pin phone jack connector at the left-center of the board. Positive of the VDC (typically, a fluctuating 1.5 to 3.5 volts reading to C; at least 0.25 volts higher than -) SA BUS communication circuit to optional economizer board, 4-stage board, fault detection & diagnostics board, netstat and/or Multi Touch gateway
<b>J8</b>	6-pin phone jack connector	Incorporates the SA BUS terminals for convenience/alternate connection of SA BUS devices, primarily used for temporary service connection of the Multi Touch gateway
<b>Item Integrated user interface at lower left corner of UCB</b>		
<b>Display</b>	On-board, 2-line x 8-character back-lit display	On-board display, buttons and joystick allow access to UCB, economizer, 4-stage and FDD board parameters
<b>ENTER</b>	Button for display menu acknowledgment and navigation	
<b>CANCEL</b>	Button for display menu navigation and zeroing of active compressor ASCD timer	
<b>JOY</b>	4-way Joystick for display menu navigation	
<b>Item USB connector at right of UCB</b>		
<b>J10</b>	Type A female Universal Serial Bus connector	Used for backup, restoration, & copying of board parameters as well as board software updating through a flash drive

**Table 23: Smart Equipment™ UCB Details (Continued)**

Description		Function & Comments
<b>J15</b>	Factory wired SA Bus connector	
<b>Optional communication sub-board at center of UCB</b>		
<b>Terminal FC BUS<sup>1</sup> connections on left edge of the communication board</b>		
<b>FC+</b>	FC ("Field Connected") BUS BACnet MSTP communication	Positive of the VDC (typically, a fluctuating 1.5 to 3.5 volts reading to COM; at least 0.25 volts higher than –) FC bus BACnet MSTP communication circuit
<b>FC–</b>	FC ("Field Connected") BUS BACnet MSTP communication	Positive of the VDC (typically, a fluctuating 1.5 to 3.5 volts reading to COM; at least 0.25 volts lower than +) FC bus BACnet MSTP communication circuit
<b>COM</b>	Common for the FC ("Field Connected") BUS BACnet MSTP communication circuit	Negative of the VDC FC bus BACnet MSTP communication circuit
<b>SHLD</b>	Shield for the FC ("Field Connected") BUS BACnet MSTP communication circuit	Earth ground reference of the cable to prevent interference on the FC bus BACnet MSTP communication circuit
<b>Item Selector in red housing at left on top edge of the communication board</b>		
<b>EOL switch</b>	End Of Line selector switch for the FC BUS BACnet MSTP communication circuit	ON selected only for the UCB that is the terminus of the FC bus BACnet MSTP communication cable to prevent signal "bounce-back"
<b>LEDs on the communication board</b>		
<b>EOL</b>	Green End Of Line indicator	Lit indicates the EOL switch is selected ON
<b>FC BUS</b>	Green FC bus communication transmission indicator	Lit/flickering indicates outgoing UCB FC bus communication is currently active, off indicates the UCB is awaiting incoming FC bus communication
<b>ISO PWR</b>	Green communication board Isolated Power indicator	Lit indicates the UCB is supplying power to the communication sub-board

1. When wiring unit and other devices using the SA Bus and FC Bus, see Table 24.

**Table 24: Cable for FC Buses and SA Buses in Order of Preference**

Bus and Cable Type	Non-Plenum Applications		Plenum Applications	
	Part Number	O.D.	Part Number	O.D.
<b>FC Bus:</b> 22 AWG Stranded, 3-Wire Twisted Shielded Cable <sup>1</sup>	Anixter: CBL-22/3-FC-PVC Belden®: B5501FE	0.138 in.	Anixter: CBL-22/3-FC-PLN Belden: B6501FE	0.140 in.
<b>SA Bus (Terminal Block):</b> 22 AWG Stranded, 4-Wire, 2 Twisted-Pair Shielded Cable	Anixter: CBL-22/2P-SA-PVC Belden: B5541FE	0.209 in.	Anixter: CBL-22/2P-SA-PLN Belden: B6541FE	0.206 in.
SA Bus (Modular Jack): 26 AWG Solid 6-Wire, 3 Twisted-Pair Cable <sup>2</sup>	—	—	Anixter preassembled: CBL-NETWORK25 CBL-NETWORK50 CBL-NETWORK75 CBL-NETWORK100	0.15 in.
<b>FC Bus:</b> 22 AWG Stranded, 3-Wire Twisted Non-Shielded Cable	Belden: B5501UE	0.135 in.	Belden: B6501UE	0.131 in.
<b>SA Bus (Terminal Block):</b> 22 AWG Stranded, 4-Wire, 2 Twisted-Pair Non-Shielded Cable	Belden: B5541UE	0.206 in.	Belden: B6541UE	0.199 in.

1. We strongly recommend 3-wire (for FC bus) and 4-wire, 2 twisted-pair (for SA bus), 22 AWG stranded, shielded cable. A 22 gauge cable offers the best performance for various baud rates, cable distances, and number of trunk devices primarily due to lower conductor-to-conductor capacitance. Shielded cable offers better overall electrical noise immunity than non-shielded cable. Observe the shield grounding requirements.
2. We recommend 26 AWG solid, 6-wire (3 twisted pairs) cable as the best fit for fabricating modular cables with the modular jack housing assembly. Be sure the cable you use fits the modular jack housing. The preassembled cables that are available from Anixter (Part No. CBL-NETWORKxxx) use 24 gauge wire.

## Operation

### Compressor Operation

Compressor Operation details include:

- a. Compressors are controlled by the Y1 through Y2 thermostat inputs. If the Lead/Lag function is turned OFF, a Y1 input energizes the C1 output when the compressor number 1 anti-short cycle delay is at 0 and all refrigerant safety devices are closed (Default 5 minutes).
- b. The FAN output for indoor fan operation energizes with any cooling output after the Indoor Fan Cool On Delay expires.
- c. When the thermostat cooling inputs are lost **and** the minimum runtime expires, the compressor outputs stage off (Default 3 minutes).
- d. A 30 second interstage delay occurs when multiple stages are requested.

**NOTE:** A Y2 input without a Y1 input energizes a C1 first and then C2 30 seconds later.

### IntelliSpeed™ Supply Fan Control

1. Setpoints and related data
  - Fan Control Type Fixed Variable
  - Occupied, No Heat Or Cool % Command 0-100%
  - Occupied, One Stage of Cool % Command 0-100%
  - Occupied, Two Stage of Cool % Command 0-100%
  - Occupied, One Stage of Heat % Command 0-100%
  - Occupied, Two Stage of Heat % Command 0-100%
  - Economizer Minimum Position 0-100%
  - Economizer Minimum Position for Low Speed Fan 0-100%
2. Outputs
  - 24 VAC from FAN on Unit Control Board (UCB) to enable VFD.
  - 2-10 vdc from VFD terminal on UCB for controlling speed of the VFD drive.
3. VFD Operation
  - 2-10vdc output from VFD terminal on UCB will operate supply fan VFD proportional to the min and max frequency settings of VFD drive (defaults 25hz - 60hz)
4. Supply Fan Only Operation
  - When there is no demand for heating or cooling, the supply fan to run operate at the percent output that relates to the "No Heat Or Cool % Command" setpoint.
5. Cooling Supply Fan Operation
  - With a demand for Cooling Stage 1 only, VFD will operate at the frequency relating to setpoint "Occupied, One Stage of Cool % Command"
  - With a demand for Two Cooling Stages, VFD will operate at the frequency relating to setpoint "Occupied, One Stage of Cool % Command"

### Economizer Sequences

Several functions can drive the economizer, including: minimum position, free cooling, economizer loading, and minimum outdoor air supply.

#### Economizer Minimum Position

The economizer minimum position is set during occupied mode when outside air is not suitable for free cooling. The position of the damper is set proportionally between the "Economizer Minimum Position and the Economizer Minimum Position Low Speed Fan" set points, in relationship to the VFD output percentage. On a constant volume single speed supply fan system both set-points should be set to the same value.

#### Free Cooling

Four types of free cooling options are available: dry bulb changeover, single enthalpy, dual enthalpy changeover, and Auto.

#### Dry Bulb Changeover

For dry bulb economizer operation, the outside air is suitable for free cooling if the outside air temperature is 1°F below the Economizer OAT Enable Setpoint **and** 1°F below the Return Air Temperature.

Free cooling is no longer available if the outside air temperature rises above **either** the Economizer OAT Enable setpoint **or** the return air temperature.

#### Single Enthalpy Changeover

For single enthalpy economizer operation, the outside air is suitable for free cooling if the outside air enthalpy is at least 1 btu/lb below the Economizer Outside Air Enthalpy Setpoint **and** the outside air temperature is no greater than the RAT plus 9°F.

If the outside air temperature rises above the RAT plus 10°F, free cooling is no longer available. The outside air temperature must drop to no greater than RAT plus 9°F to enter free cooling again.

Free cooling is no longer available if the outside air enthalpy rises above the Economizer Outside Air Enthalpy Setpoint.

#### Dual Enthalpy Changeover

For dual enthalpy economizer operation, the outside air enthalpy must be lower than the return air enthalpy by 1 btu/lb **AND** the outside air temperature is no greater than the RAT plus 9°F.

#### Auto

The control determines the type of free cooling changeover based on which sensors are present and reliable. Conditions include:

- Return and outside air dry bulb = dry bulb changeover
- Return and outside air dry bulb and outside air humidity = single enthalpy



- Return and outside air dry bulb and return and outside air humidity = dual enthalpy
- If either the return or outside air dry bulb sensors are unreliable, free cooling is not available

## Free Cooling Operation

When the control determines that the outside air is suitable, the first stage of cooling will always be free cooling.

### Thermostat

In free cooling, with a thermostat input to Y1, the dampers modulate to control the supply air temperature to the Economizer Setpoint +/- 1°F (default 55°F).

If the thermostat provides an input to Y2 **and** the parameter Compressors Off in Free Cooling is turned OFF a compressor output energizes. The economizer dampers continue to modulate to control the supply air temperature to the Economizer Setpoint.

If the supply air temperature cannot be maintained within 5°F of the economizer setpoint, the first stage compressor (C1) will be turned on. Second stage compressor (C2) will be added as needed to keep the supply air temperature within the 5°F of the economizer setpoint.

### Sensor

In free cooling, with a demand from the zone/return sensor for the first stage of cooling, the dampers modulate to control the supply air temperature to the Economizer Setpoint +/- 1°F.

If the economizer output is at 100% **and** the SAT is greater than the Economizer setpoint + 1°F, the control starts a 12-minute timer to energize a compressor output.

If at any time the economizer output drops below 100% the timer stops and resets when the economizer output returns to 100%.

Once a compressor output is turned ON, the economizer dampers continue to modulate to control the supply air temperature to the Economizer Setpoint.

At no time will a compressor output be turned ON if the economizer output is less than 100%, even if the differential between zone (or return) temperature and the current cooling setpoint is great enough to demand more than one stage of cooling.

If the economizer output goes to minimum position **and** the SAT is less than Economizer Setpoint -1°F, the control starts a 12-minute timer to de-energize a compressor output.

If at any time the economizer output goes above the minimum position the timer stops and resets when the economizer output returns to minimum position.

If the demand for cooling from the space/return is satisfied, the economizer output will modulate to minimum position and the compressor outputs will be de-energized as long as their minimum run timers have expired.

## Economizer Loading

### Power Exhaust

#### Setpoints

a. Economizer Enable	ON
b. Power Exhaust Enable	ON
c. Modulating Power Exhaust	OFF
d. Exhaust VFD Installed	OFF
e. Building Pressure Sensor Enabled	OFF
f. Econo Damper Position For Exh Fan	ON Percent
g. Econo Damper Position For Exh Fan	OFF Percent

#### Inputs

No inputs are present for non-modulating power exhaust.

#### Outputs

- 2-10 VDC from ECON on Economizer Expansion module
- 24 VAC from EX-FAN to energize exhaust fan on Economizer Expansion module

#### Operation

Operation details include:

- Compares economizer output to the Economizer Damper Position For Exhaust Fan On and OFF.
- Energizes exhaust fan when economizer output is above Economizer Damper Position For Exhaust Fan On.
- De-energizes exhaust fan when economizer output is below the Economizer Damper Position for Exhaust Fan OFF



Figure 25: SE-ECO1001-1 Economizer Controller

Table 25: Smart Equipment™ Economizer Board Details

Board Label	Cover Label	Description	Function & Comments
<b>Directional orientation: viewed with the center text of the cover label upright</b>			
<b>ANALOG INPUTS Terminal at left on upper edge of economizer board</b>			
<b>C</b>	COM	24 VAC common/0-10 VDC negative for economizer actuator position feedback	Connects through circuit trace to 24V~ IN pin COM
<b>IN2</b>	ECOFB	0-10 VDC positive input from Economizer actuator position Feedback	EconDampPos parameter reports input status (0-100%). Used to meet Cali. Title 24 requirements for economizer actuator position feedback
<b>R</b>	24V~	24 VAC hot supplied for economizer actuator position feedback	Connects through circuit trace to 24V~ IN pin HOT
<b>C</b>	COM	Mixed Air Temperature sensor input from 10KΩ @ 77°F, Type III negative temperature coefficient thermistor	MAT parameter reports input status (°F/°C), 3.65 VDC reading MAT (+) to COM (-) with open circuit. Read-only use in current control revision.
<b>IN1</b>	MAT		
<b>LEDs at left on upper edge of economizer board</b>			
<b>POWER</b>	POWER	Green UCB power indicator	Lit indicates 24 VAC is present at 24V~ IN COM and HOT pins
<b>FAULT</b>	FAULT	Red networking error and firmware error indicator	1/10th second on/off flashing indicates a networking error (polarity, addressing, etc.) or a firmware error (likely correctable with re-loading from USB flash drive)
<b>SA BUS</b>	SA BUS	Green UCB SA bus communication transmission indicator	Lit/flickering indicates UCB-to-economizer board SA bus communication is currently active, off indicates the economizer board is awaiting SA bus communication
<b>SA BUS<sup>1</sup> Pin connections at left on upper edge of economizer board</b>			
<b>C</b>	COM	Common for SA BUS power and communication circuits	EconCtrlr parameter reports UCB-to-economizer board SA bus communication status. Negative of the SA BUS communication circuit to the UCB. Through the unit wiring harness, may continue on to the 4-stage board and/or fault detection & diagnostics board

**Table 25: Smart Equipment™ Economizer Board Details (Continued)**

Board Label	Cover Label	Description	Function & Comments
-	-	Communication for SA BUS devices	EconCtrlr parameter reports UCB-to-economizer board SA BUS communication status. Positive of the VDC (typically, a fluctuating 1.5 to 3.5 volts reading to C; at least 0.25 volts lower than +) SA BUS communication circuit to the UCB. Through the unit wiring harness, may continue on to the 4-stage board and/or fault detection & diagnostics board
+	+	Communication for SA BUS devices	EconCtrlr parameter reports UCB-to-economizer board SA BUS communication status. Positive of the VDC (typically, a fluctuating 1.5 to 3.5 volts reading to C; at least 0.25 volts higher than -) SA BUS communication circuit to the UCB. Through the unit wiring harness, may continue on to the 4-stage board and/or fault detection & diagnostics board
<b>ANALOG OUTPUTS Pin at center on upper edge of economizer board</b>			
J4	EX VFD	2-10 VDC positive output for the modulating power Exhaust fan Variable Frequency Drive/ discharge damper modulating power exhaust actuator	ExFanVFD parameter reports output status (0-100%) when ExFType selection is Variable Frequency Fan; EAD-O parameter reports output status (0-100%) when ExFType selection is Modulating Damper. Used to ramp the power exhaust fan VFD/ position the discharge damper actuator.
	COM	24 VAC common/0-10 VDC negative for the power exhaust variable frequency drive/ discharge damper modulating power exhaust actuator	Connects through circuit trace to 24V~ IN pin COM
	24V~	24 VAC hot supplied for the discharge damper modulating power exhaust actuator and economizer actuator	Connects through circuit trace to 24V~ IN pin HOT
	ECON	2-10 VDC output for the Economizer actuator	Econ parameter reports output status (0-100%). Used to position the economizer actuator for minimum position, free cooling, demand ventilation, cooling economizer loading and purge functions
	COM	24 VAC common/0-10 VDC negative for economizer actuator	Connects through circuit trace to 24V~ IN pin COM
<b>BINARY OUTPUTS Pin at right on upper edge of economizer board</b>			
J3	24V~	24 VAC hot supplied for an incremental (floating control) economizer actuator	Connects through circuit trace to 24V~ IN pin HOT
	ACT-A	24 VAC hot outputs to position an incremental (floating control) economizer actuator	Unused in current control revision
	ACT-B	24 VAC return	Unused in current control revision
	COM	24 VAC common for an incremental (floating control) economizer actuator	Connects through circuit trace to 24V~ IN pin COM
	EX-FAN	24 VAC hot output to energize power exhaust fan contactor coil/VFD enable relay coil	ExFan parameter reports output status (Off-On) when ExFType selection is Non-Modulating, Modulating Damper or Variable Frequency Fan. Used to turn on/enable the power exhaust fan motor.
	COM	24 VAC common/0-10 VDC negative for economizer actuator	Connects through circuit trace to 24V~ IN pin COM
<b>24V~ IN Pin connections at right on upper edge of economizer board</b>			
C	COM	24 VAC transformer Common referenced to cabinet ground	24 VAC common connection to power the economizer board. Connects through circuit traces to C/COM terminals and pins distributed on the economizer board.

**Table 25: Smart Equipment™ Economizer Board Details (Continued)**

Board Label	Cover Label	Description	Function & Comments
R	HOT	24 VAC transformer HOT	24 VAC hot connection to power the economizer board. Connects through circuit traces to R/24V~ terminals and pins distributed on the economizer board.
<b>ANALOG INPUTS Terminal on lower edge of economizer board</b>			
R	24V~	24 VAC hot supplied for the outdoor air humidity sensor	Connects through circuit trace to 24V~ IN pin HOT
IN3	OAH	0-10 VDC positive input from the Outdoor Air Humidity sensor	OAH parameter reports input status (0-100%H). Used in outdoor air enthalpy calculation for dual enthalpy economizer free cooling changeover.
C	COM	24 VAC common/0-10 VDC negative for the outdoor air humidity sensor	Connects through circuit trace to 24V~ IN pin COM
R	24V~	24 VAC hot supplied for the supply air humidity sensor	Connects through circuit trace to 24V~ IN pin HOT
IN4	SAH	0-10 VDC positive input from the Supply Air Humidity sensor	SAH parameter reports input status (0-100%H). Unused in current control revision.
C	COM	24 VAC common/0-10 VDC negative for the supply air humidity sensor	Connects through circuit trace to 24V~ IN pin COM
R	24V~	24 VAC hot supplied for the indoor air quality sensor	Connects through circuit trace to 24V~ IN pin HOT
IN5	IAQ	0-10 VDC positive input from the Indoor Air Quality sensor	IAQRange parameter sets the CO2 parts per million measured by the indoor air quality sensor when it outputs 10 VDC; IAQ parameter reports input status (0-5000ppm). Used for demand ventilation functions if the NetIAQ parameter indicates ?Unrel.
C	COM	24 VAC common/0-10 VDC negative for the indoor air quality sensor	Connects through circuit trace to 24V~ IN pin COM
R	24V~	24 VAC hot supplied for the outdoor air quality sensor	Connects through circuit trace to 24V~ IN pin HOT
IN6	OAQ	0-10 VDC positive input from the Outdoor Air Quality sensor	OAQRange parameter sets the CO2 parts per million measured by the outdoor air quality sensor when it outputs 10 VDC; OAQ parameter reports input status (0-5000ppm). Used for demand ventilation function when DVent-Mode selection is Diff between IAQ and OAQ and the NetOAQ parameter indicates ?Unrel.
C	COM	24 VAC common/0-10 VDC negative for the outdoor air quality sensor	Connects through circuit trace to 24V~ IN pin COM
R	24V~	24 VAC hot supplied for the air monitoring station sensor	Connects through circuit trace to 24V~ IN pin HOT
IN7	FR AIR	0-10 VDC positive input from the air monitoring station sensor	MOA-Range parameter sets the cubic feet per minute/liters per second measured by the air monitoring station sensor when it outputs 10 VDC; Fr Air parameter reports input status (0-50000CFM/23595lps). Used for economizer minimum position reset in speed-controlled indoor blower applications.
C	COM	24 VAC common/0-10 VDC negative for the air monitoring station sensor	Connects through circuit trace to 24V~ IN pin COM
R	24V~	24 VAC hot supplied for the building pressure sensor	Connects through circuit trace to 24V~ IN pin HOT
IN8	BLDG PRES	0-5 VDC positive input from the Building Pressure sensor	BldgPres parameter reports input status (-.250-.250"/w/-.062-.062kPa). Used for modulating power exhaust functions when ExFType selection is Modulating Damper or Variable Frequency Fan.

**Table 25: Smart Equipment™ Economizer Board Details (Continued)**

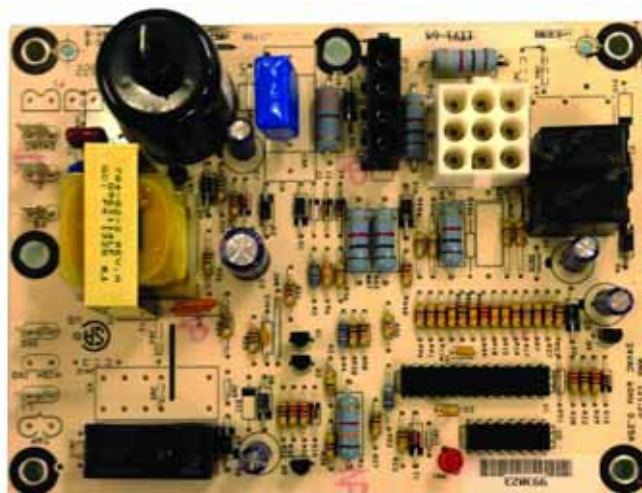
Board Label	Cover Label	Description	Function & Comments
C	COM	24 VAC common/0-5 VDC negative for the building pressure sensor	Connects through circuit trace to 24V~ IN pin COM
<b>BINARY INPUTS at right on lower edge of economizer board</b>			
IN9	PURGE	24 VAC hot input from the PURGE dry contact	Purge parameter reports input status (False with 0 VAC input-True with 24 VAC input). When Purge status is True, heating and cooling operation is prevented, the indoor blower and power exhaust fan operate, the economizer actuator is positioned to 100%.
	24V~	24 VAC hot supplied for the purge dry contact	Connects through circuit trace to 24V~ IN pin HOT
IN10	EX VFD FLT	24 VAC hot input from the power Exhaust Variable Frequency Drive Fault contact	ExFanVFDFlt parameter reports input status (Normal with 0 VAC input-Alarm with 24 VAC input) when ExFType selection is Variable Frequency Fan. When ExFanVFDFlt status is Alarm, EX-FAN fan output is prevented.
	24V~	24 VAC hot supplied for the power exhaust variable frequency drive fault contact	Connects through circuit trace to 24V~ IN pin HOT

1. When wiring unit and other devices using the SA Bus and FC Bus, see Table 24.

### Indoor Air Quality AQ

Indoor Air Quality (indoor sensor input): Terminal AQ accepts a +2 to +10 Vdc signal with respect to the (AQ1) terminal. When the signal is below its set point, the actuator is allowed to modulate normally in accordance with the enthalpy and mixed air sensor inputs. When the AQ signal exceeds its set point setting and there is no call for free cooling, the actuator is proportionately modulated from the 2 to 10 Vdc signal, with 2 Vdc corresponding to full closed and 10 Vdc corresponding to full open. When there is no call for free cooling, the damper position is limited by the IAQ Max damper position setting. When the signal exceeds its set point (Demand Control Ventilation Set Point) setting and there is a call for free cooling, the actuator modulates from the minimum position to the full open position based on the highest call from either the mixed air sensor input or the AQ voltage input.

- Optional CO<sub>2</sub> Space Sensor Kit Part # 2AQ04700524B
- Optional CO<sub>2</sub> Sensor Kit Part # 2AQ04700624C



**Figure 26: Ignition Control Board**

### Gas Heating Operation

- a. Heating stages are controlled by the W1 through W2 thermostat inputs. A W1 or W2 input energizes a H1 or H1/H2 output.
- b. When the pre-ignition process is complete the ignition module energizes the gas valve and provides a 24 V input to the MV terminal on the UCB.
- c. The FAN ON HEAT DELAY timer starts as soon as 24 V is present on MV terminal. When the timer expires the FAN output for the indoor fan operation energizes. If 24 V is not received on the MV terminal within 6 minutes, an alarm appears and the fan output energizes immediately and remains On until the alarm clears.

- d. When the thermostat heat inputs are lost **and** the 120 second Minimum Heat Run Timers have expired, heating outputs stage off. The FAN OFF HEAT DELAY timer starts when 24 V is removed from the MV terminal. When the timer expires, the FAN output for the indoor fan operation de-energizes.

**NOTE:** If 24 V is lost on the MV terminal during the same heat cycle, an alarm appears and the fan output energizes **and** remains On until 24 V is present again on the MV terminal.

**NOTE:** If 24 V is present on the MV terminal without a call for heat, an alarm appears and the fan output energizes. If this condition occurs for 6 minutes an alarm appears, and remains, until the alarm condition is cleared.

- e. At any time, if 24 V is lost on the LIMIT terminal, the FAN output for indoor fan operation is energized. If 24 V is lost on the LIMIT input 3 times in 1 hour, an alarm appears and the FAN output is energized. The heating H1 and H2 outputs are de-energized until the alarm is cleared.

## Gas Heat Ignition Control Board Function

### Ignition Control Board on Standby

The Ignition Control Board (ICB) has all outputs de-energized and monitors the thermostat and flame sense. The ICB resets ignition trial and flame loss counters. The ICB begins a call for heat when W1 is energized at the Unit Control Board (UCB). The ICB ignores W2 until ignition has been established.

### Call for heat

The ICB checks to see if the pressure switch is open. If the pressure switch is closed, the ICB flashes "3" on the LED and waits indefinitely for it to open. When the pressure switch is sensed as open, the ICB begins pressure switch proving period. If the call for heat is lost, the ICB goes back to Standby.

### Pressure switch proving

The ICB energizes the induced draft motor and waits for the low pressure switch to close. When the low pressure switch closes, the control begins Pre-purge period. If the call for heat is lost, the control de-energizes the inducer without post-purge and returns to standby.

If the low pressure switch does not close within 10 seconds of inducer energizing, the control flashes "2" on the LED. If the pressure switch does not close within 5 minutes of inducer energizing, the control shuts off the inducer for 30 seconds, then energizes the inducer for another 5 minute try to close the pressure switch. This cycle continues indefinitely until either the pressure switch is proved closed, or the call for heat ends.

### Pre-purge

The ICB monitors the low pressure switch and ensures it remains closed during pre-purge. If the pressure switch opens, the control goes back to pressure switch proving mode. The control waits for a 15 second pre-purge period, then begins the ignition trial.

### Ignition trial period

The ICB energizes the main gas valve, second stage gas valve and spark outputs for a 10 second Ignition trial. The control de-energizes the spark when flame is sensed and enters a flame stabilization period.

If flame is not established within the ignition trial period, the control de-energizes the spark and gas valve and checks for maximum number of ignition trials. The ICB has a maximum number of 3 ignition trials. If the control has attempted the maximum number of ignition trials within the same call for heat without flame, the control will lockout flashing "4" on the LED. If the control has attempted less than maximum ignition trials, it begins an inter-purge period before attempting another ignition trial.

If the call for heat is lost during an ignition trial period, the control immediately de-energizes spark and gas. The control runs the inducer motor through a post purge period before de-energizing.

If the pressure switch is lost during an ignition trial period, the control immediately de-energizes spark and gas. The control begins pressure switch proving before an inter-purge and re-ignition attempt.

### Flame stabilization period

If a flame is detected during the Ignition Trial Period, the ICB then enters the flame stabilization period. If a flame is not detected in 2 seconds, the main valve is de-energized and a retry operation begins. The flame stabilization period lasts 10 seconds. flame detection must be lost for 2 seconds during flame stabilization for the main valve to be de-energized. When the flame stabilization period has ended, a loss of flame detection for 3/4 seconds will result in the main valve being de-energized.

If flame is lost during the flame stabilization period, the control counts it as a flame loss and retries ignition or locks out as described in Low heat section.

### Main Burner operation

#### High heat warm-up

Two stage models run high heat for the first 30 seconds following flame stabilization period regardless of W2 demand. If W2 is not energized at the end of this 30 second period the control de-energizes the high gas output. If W2 is energized the control remains on high heat.

#### Low heat

The ICB keeps the main gas valve and induced draft motor energized while continuously monitoring the call for heat, low pressure switch, and flame status.

If the call for heat (W1) is lost, the control de-energizes the gas valve and begins post purge.

If low pressure switch opens, the control de-energizes the gas valve and begins pressure switch proving mode.

If flame is lost, the control de-energizes the gas valve within 2.0 second and counts the flame loss. If flame has been lost more than 5 times within the same call for heat, the control locks out flashing "5" on the LED. If flame has been lost less than 5 times, the control attempts re-ignition after a 30 second inter-purge period.

#### High heat

The ICB recognizes a call for 2nd stage heat when W2 is energized. The control energizes the high gas output.

If the call for 2nd stage heat goes away and the 1st stage call remains, the control de-energizes the high gas valve and returns to low heat operation.

Response to loss of W1, low pressure switch, and flame are identical to low heat operation.

#### Post Purge

The ICB runs the induced draft motor for a 5 second post-purge period, then de-energizes the inducer. If a call for heat occurs during post-purge, the control finishes the post-purge, drops inducer out to re-prove open pressure switch before continuing with the heat cycle.

#### Lockout

While in lockout, the ICB keeps the main gas valve and induced draft motor de-energized.

Lockouts due to failed ignition or flame losses may be reset by removing the call for heat (W1) for more than 1 second, but less than 20 seconds, or by removing power from the control for over 0.25 seconds. The control will automatically reset lockout after 60 minutes.

Lockouts due to detected internal control faults will reset after 60 minutes or power interruption.

#### High temperature limit switch

If the high temperature limit switch is open the control will run the inducer, de-energize the gas valve, and flash "6" on the LED. When the high temperature switch closes, the control will restart the ignition sequence beginning with pre-purge.

If the high temperature limit is open for more than 6 minutes continuously during a call for heat, it is assumed that the main blower has failed and the control shall enter a hard lockout and flash a "9" on the LED. During the hard lockout, the control will continue to run the inducer as long as the limit switch is open. If the limit switch recloses in this hard lockout condition, the inducer will run a post purge and then shutoff. The control shall remain locked out until power is removed and shall not reset automatically.

#### Roll-out switch

If the roll-out switch opens for more than 0.25 seconds, the ICB will run the inducer for a post-purge period, immediately de-energize the gas valve, and flash "7" on the LED.

If the roll-out switch closes, the control shall remain locked out until power removed or "W" is removed. Rollout switch lockout shall not reset automatically.

#### Power interruptions

Power interruptions less than 0.80 seconds shall not cause the ICB to interrupt the heat sequence. Power interruptions over 0.250 seconds will cause the control reset lockout and ignition trial counters. Power interruptions of any duration shall not cause lockout or any operation requiring manual intervention.

#### Flame present with Gas off

If flame is sensed for longer than 2.0 seconds during a period when the gas valve should be closed, the ICB will enter lockout. The control will turn on the inducer blower while the flame is present.

#### Welded gas valve relay response

If either or both Main and 2nd Stage Gas valve outputs are sensed to be off for more than 1 second when commanded to be **ON** the ICB shuts off all outputs and enters lockout.

If the Main valve output is sensed to be energized for more than 1 second when commanded to be off, the control de-energizes the induced draft motor (if flame is not present) to attempt to open the pressure switch to de-energize the gas valve. If the Main gas valve is still sensed as energized after the inducer has been off for 15 seconds, the control re-energizes the inducer to attempt to vent the unburned gas. In either case, the control locks out.

## Start-Up (Cooling)

#### Prestart Check List

After installation has been completed:

1. Check the electrical supply voltage being supplied. Be sure that it is the same as listed on the unit nameplate.
2. Set the room thermostat to the off position.
3. Turn unit electrical power on.
4. Set the room thermostat fan switch to on.
5. Check indoor blower rotation.
  - If blower rotation is in the wrong direction. Refer to Phasing Section in general information section.
 Check blower drive belt tension.
6. Check the unit supply air (CFM).
7. Measure evaporator fan motor's amp draw.
8. Set the room thermostat fan switch to off.
9. Turn unit electrical power off.

#### Operating Instructions

1. Turn unit electrical power on.

**NOTE:** Prior to each cooling season, the crankcase heaters where equipment must be energized at least 10 hours before the system is put into operation.

2. Set the room thermostat setting to lower than the room temperature.
3. First stage compressors will energize after the built-in time delay (five minutes).

#### Post Start Check List

1. Verify proper system pressures.
2. Measure the temperature drop across the evaporator coil.

### Start-Up (Gas Heat)

#### Pre-Start Check List

Complete the following checks before starting the unit.

1. Check the type of gas being supplied. Be sure that it is the same as listed on the unit nameplate.
2. Make sure that the vent outlet and combustion air inlet are free of any debris or obstruction.

#### Operating Instructions

### CAUTION

This furnace is equipped with an automatic re-ignition system. DO NOT attempt to manually light the pilot.

#### Lighting The Main Burners

1. Turn "OFF" electric power to unit.
2. Turn room thermostat to lowest setting.
3. Turn gas valve switch to "ON" position (See Figures 28 thru 30).
4. Turn "ON" electric power to unit.
5. If thermostat set temperature is above room temperature, the main burners will ignite.

#### Post Start Checklist

After the entire control circuit has been energized and the heating section is operating, make the following checks:

1. Check for gas leaks in the unit piping as well as the supply piping.

### WARNING

#### FIRE OR EXPLOSION HAZARD

Failure to follow the safety warning exactly could result in serious injury, death or property damage.

Never test for gas leaks with an open flame. Use a commercially available soap solution made specifically for the detection of leaks to check all connections. A fire or explosion may result causing property damage, personal injury or loss of life.

2. Check for correct manifold gas pressures. (See CHECKING GAS INPUT.)
3. Check the supply gas pressure. It must be within the limits shown on the rating nameplate. Supply pressure should be checked with all gas appliances in the building at full fire. At no time should the standby gas pressure exceed 10.5 in. or the operating pressure drop below 4.5 in. for natural gas units. If gas pressure is outside these limits, contact the local gas utility or propane supplier for corrective action.

#### Shut Down

1. Set the thermostat to the lowest temperature setting.
2. Turn "OFF" all electric power to unit.
3. Open gas heat access panel.
4. Turn gas valve switch to "OFF" position (See Figures 28 thru 30).

### Checking Gas Heat Input

#### Single Stage Gas Heat

This unit has a single stage of gas heat. The intended input for each furnace is shown in Table 27. The table applies to units operating on 60 Hz power only.

To determine the rate of gas flow (Single Stage).

1. Turn off all other gas appliances connected to the gas meter.
2. Turn on the furnace and make sure the thermostat is calling for heat.
3. Measure the time needed for one revolution of the hand on the lowest increment dial on the meter. A typical gas meter has a 1/2 or a 1 cubic foot test dial.
4. Using the number of seconds it takes for one revolution of the dial, calculate the cubic feet of gas consumed per hour. (See example below).
5. If necessary, adjust the regulator as discussed in the section "Manifold Gas Pressure Adjustment". **Be sure not to over-fire the furnace.** If in doubt, it is better to leave the furnace slightly under-fired. Repeat Steps 1-5.

#### Two Stage Gas Heat

This unit has two stages of gas heat. First stage input is considered the minimum input for the furnace. The intended input for each furnace is shown in Table 27. The table applies to units operating on 60 Hz power only.

To determine the rate of gas flow (Second Stage).

1. Turn off all other gas appliances connected to the gas meter.
2. Turn on the furnace and make sure the thermostat is calling for Second stage (100% input) heat.
3. Measure the time needed for one revolution of the hand on the lowest increment dial on the meter. A typical gas meter has a 1/2 or a 1 cubic foot test dial.



4. Using the number of seconds it takes for one revolution of the dial, calculate the cubic feet of gas consumed per hour. (See example below).
5. If necessary, adjust the high pressure regulator as discussed in the section "Manifold Gas Pressure Adjustment". **Be sure not to over-fire the furnace on second stage.** If in doubt, it is better to leave the second stage of the furnace slightly under-fired. Repeat Steps 1-5.

To determine the rate of gas flow (First Stage)

1. Turn off all other gas appliances connected to the gas meter.
2. Turn on the furnace and make sure the thermostat is calling for first stage heat.
3. Even when the thermostat is calling for first stage heat, the unit will light on second stage and will run on second stage for 1 minute. Allow this one-minute time period to expire and be certain the unit is running on first stage.
4. Measure the time needed for one revolution of the hand on the lowest increment dial on the meter. A typical gas meter has a 1/2 or a 1 cubic foot test dial.
5. Using the number of seconds it takes for one revolution of the dial, calculate the cubic feet of gas consumed per hour (See example below).
6. If necessary, adjust the low pressure regulator as discussed in the section "Manifold Gas Pressure Adjustment". **Be sure not to under-fire the furnace on first stage.** If in doubt, it is better to leave the first stage of the furnace slightly over-fired (Refer to Table 26 for input value.). Repeat Steps 1-6.

**Table 26: Gas Rate Cubic Feet Per Hour**

Seconds for One Rev.	Size of Test Dial	
	1/2 cu. ft.	1 cu. ft.
10	180	360
12	150	300
14	129	257
16	113	225
18	100	200
20	90	180
22	82	164
24	75	150
26	69	138
28	64	129
30	60	120
32	56	113
34	53	106
36	50	100
38	47	95
40	45	90
42	43	86
44	41	82
46	39	78
48	37	75
50	36	72
52	35	69
54	34	67
56	32	64
58	31	62
60	30	60

**NOTE:** To find the Btu input, multiply the number of cubic feet of gas consumed per hour by the Btu content of the gas in your particular locality (contact your gas company for this information as it varies widely from area to area).

#### EXAMPLE

By actual measurement, it takes 19 seconds for the hand on a 1 cubic foot dial to make a revolution with a 200,000 Btuh furnace running. To determine rotations per minute, divide 60 by 19 = 3.16. To calculate rotations per hour, multiply 3.16 • 60 = 189.6. Multiply 189.6 • 1 (0.5 if using a 1/2 cubic foot dial) = 189.6. Multiply 189.6 • (the Btu rating of the gas). For this example, assume the gas has a Btu rating of 1050 Btu/ft.<sup>3</sup>. The result of 199,000 Btuh is within 2% of the 200,000 Btuh rating of the furnace.

#### Manifold Gas Pressure Adjustment

##### Single Stage

This gas furnace has one stage of gas heat. Therefore, the gas valve has one adjustment screw located under a cover screw on the valve (See Figure 28).

Manifold pressure adjustment procedure.

1. Turn off all power to the unit.
2. Using the outlet pressure port on the gas valve, connect a manometer to monitor the manifold pressure.
3. Remove cover screw covering the pressure adjustment screw.

4. Turn on power to the unit.
5. Set thermostat to call for heat and start furnace.
6. If necessary, using a screwdriver, turn the adjustment screw clockwise to increase manifold pressure or counterclockwise to decrease manifold pressure.
7. Once pressure has been checked, replace the plastic cap covering the pressure adjustment screw.

### Two Stage

This gas furnace has two heat stages. Therefore, the gas valve has two adjustment screws located under two cover screws. The second stage adjustment screw is adjacent to the "HI" marking on the valve and the first stage adjustment screw is located adjacent to the "LO" marking on the valve (See Figure 29 thru 30).

Manifold pressure adjustment procedure.

Adjust second stage (Refer to Table 26 for input value.) pressure first, then adjust first stage (Refer to Table 27 for input value.) pressure.

1. Turn off all power to the unit.
2. Using the outlet pressure port on the gas valve, connect a manometer to monitor the manifold pressure.
3. Remove cover screws covering HI and LO pressure adjustment screws.
4. Turn on power to the unit.
5. Set thermostat to call for second stage heat and start furnace.
6. If necessary, using a screwdriver, turn the second stage adjustment screw (adjacent to the "HI" marking on the valve) clockwise to increase manifold pressure or counterclockwise to decrease manifold pressure.
7. After the high manifold pressure has been checked, adjust the thermostat to call for first stage heat.
8. If necessary, using a screwdriver, turn the first stage adjustment screw (adjacent to the "LO" marking on the valve) clockwise to increase manifold pressure or counterclockwise to decrease manifold pressure.
9. Once pressure has been checked, replace the cover screws covering the HI and LO pressure adjustment screws.

**Table 27: Gas Heat Stages**

Model (Size)	Gas Heat Description	Opt.	# of Burner Tubes	1st Stage Input (Mbh)	2nd Stage Input (Mbh)	Total Input (Mbh)
ZY04 (3) Single Phase	Low, NOx	L	2	-	56	56
	Low	D	2	-	70	70
	Med, NOx	M	3	-	90	90
	Med	E	3	-	112	112
ZY04 (3) Three Phase	Low, NOx	L	2	-	56	56
	Low	D	2	49	70	70
	Med, NOx	M	3	-	90	90
	Med	E	3	82	112	112
ZY05 (4) Single Phase	Low, NOx	L	2	-	56	56
	Low	D	2	-	70	70
	Med, NOx	M	3	-	90	90
	Med	E	3	-	112	112
	High Nox	N	3	-	116	116
ZY05 (4) Three Phase	High	F	3	-	142	142
	Low, NOx	L	2	-	56	56
	Low	D	2	49	70	70
	Med, NOx	M	3	-	90	90
	Med	E	3	82	112	112
ZY06 (5) Single Phase	High Nox	N	3	-	118	118
	High	F	3	100	145	145
	Low, NOx	L	2	-	56	56
	Low	D	2	-	70	70
	Med, NOx	M	3	-	90	90
ZY06 (5) Three Phase	Med	E	3	-	112	112
	High Nox	N	3	-	118	118
	High	F	3	100	145	145
	Low	D	2	57	72	72
	Med	E	3	90	125	125
ZY07 (6)	High	F	3	110	150	150
	Low	D	2	57	72	72
	Med	E	3	90	125	125
ZYA7 (6)	High	F	3	110	150	150
	Low	D	3	90	125	125
	Med	E	4	125	180	180
ZY08 (7.5)	High	F	5	176	220	220
	Low	D	3	90	125	125
	Med	E	4	125	180	180
ZY09 (8.5)	High	F	5	176	220	220
	Low	D	4	125	180	180
	Med	E	5	176	220	220
ZY12 (10)	High	F	5	200	250	250

### Adjustment Of Temperature Rise

The temperature rise (the difference of temperature between the return air and the heated air from the furnace) must lie within the range shown on the unit rating plate and the data in Table 10.

After the temperature rise has been determined, the CFM can be calculated as follows:

$$\text{CFM} = \text{Btu Input} \cdot \frac{0.8}{(1.08 \cdot \Delta^{\circ}\text{F})}$$

After about 20 minutes of operation, determine the furnace temperature rise. Take readings of both the return air and the

heated air in the ducts (about 6 feet from the furnace) where they will not be affected by radiant heat. Increase the blower CFM to decrease the temperature rise; decrease the blower CFM to increase the rise (See SUPPLY AIR DRIVE ADJUSTMENT).

**NOTE:** Each gas heat exchanger size has a minimum allowable CFM. Below this CFM, the limit will open.

### Burners/Orifices Inspection/Service

Before checking or changing burners or orifices, CLOSE MAIN MANUAL SHUT-OFF VALVE AND SHUT OFF ALL POWER TO THE UNIT.

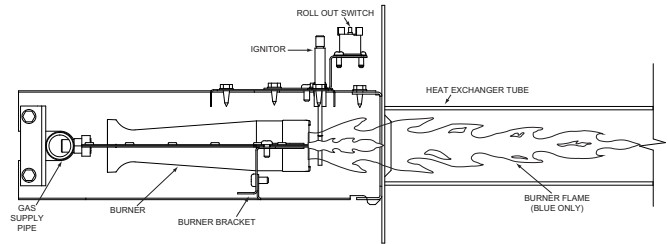
1. Open the union fitting just upstream of the unit gas valve and downstream from the main manual shut-off valve in the gas supply line.
2. Remove the screws holding each end of the manifold to the manifold supports.
3. Disconnect wiring to the gas valve. Remove the manifold & gas valve assembly. Orifices can now be inspected and/or replaced.

To service burners, complete step 4.

4. Remove the heat shield on top of the manifold supports. Burners are now accessible for inspection and/or replacement.

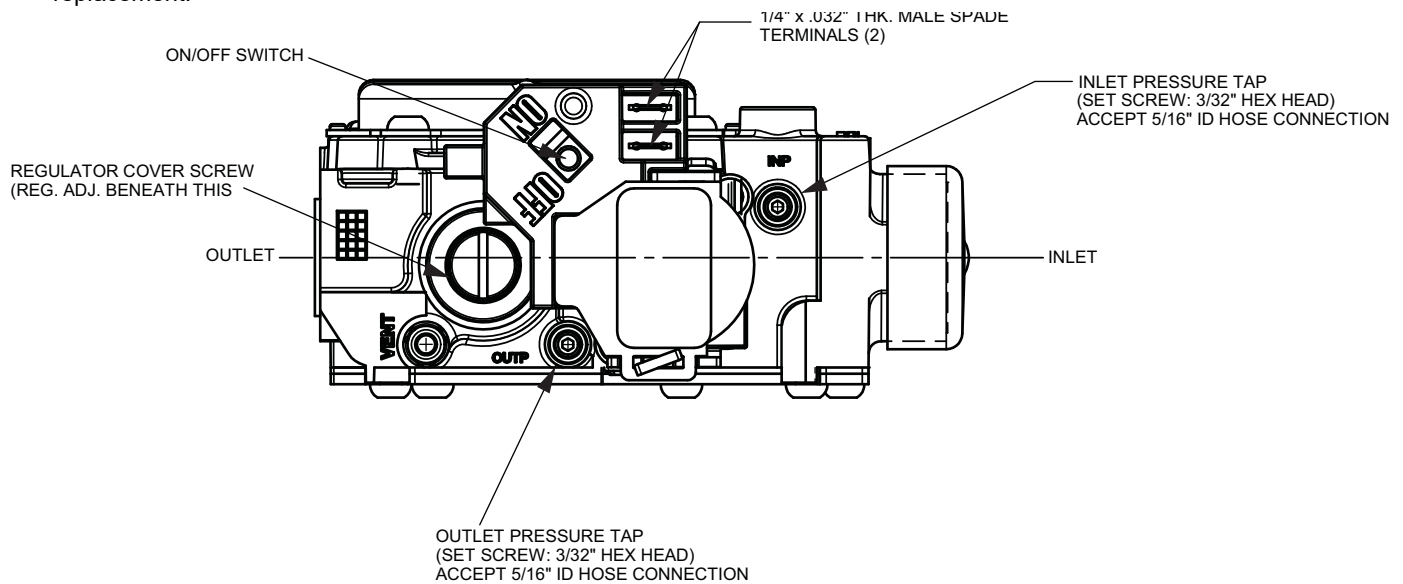
**NOTE:** Reverse the above procedure to replace the assemblies.

Make sure that burners are level and seat at the rear of the gas orifice.

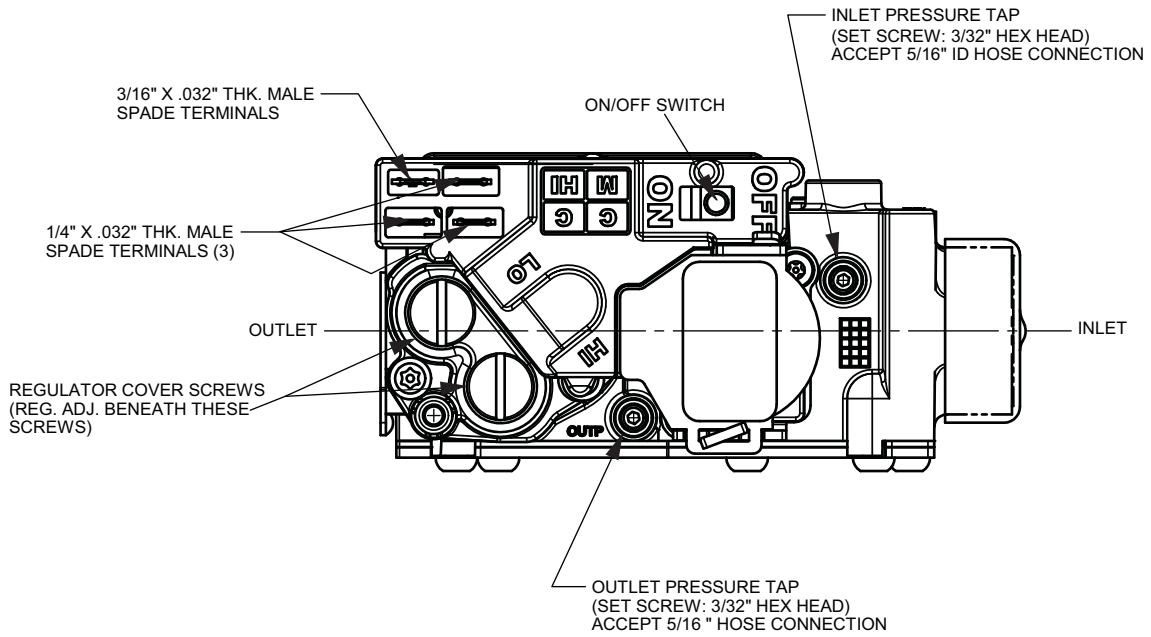


**Figure 27: Typical Flame**

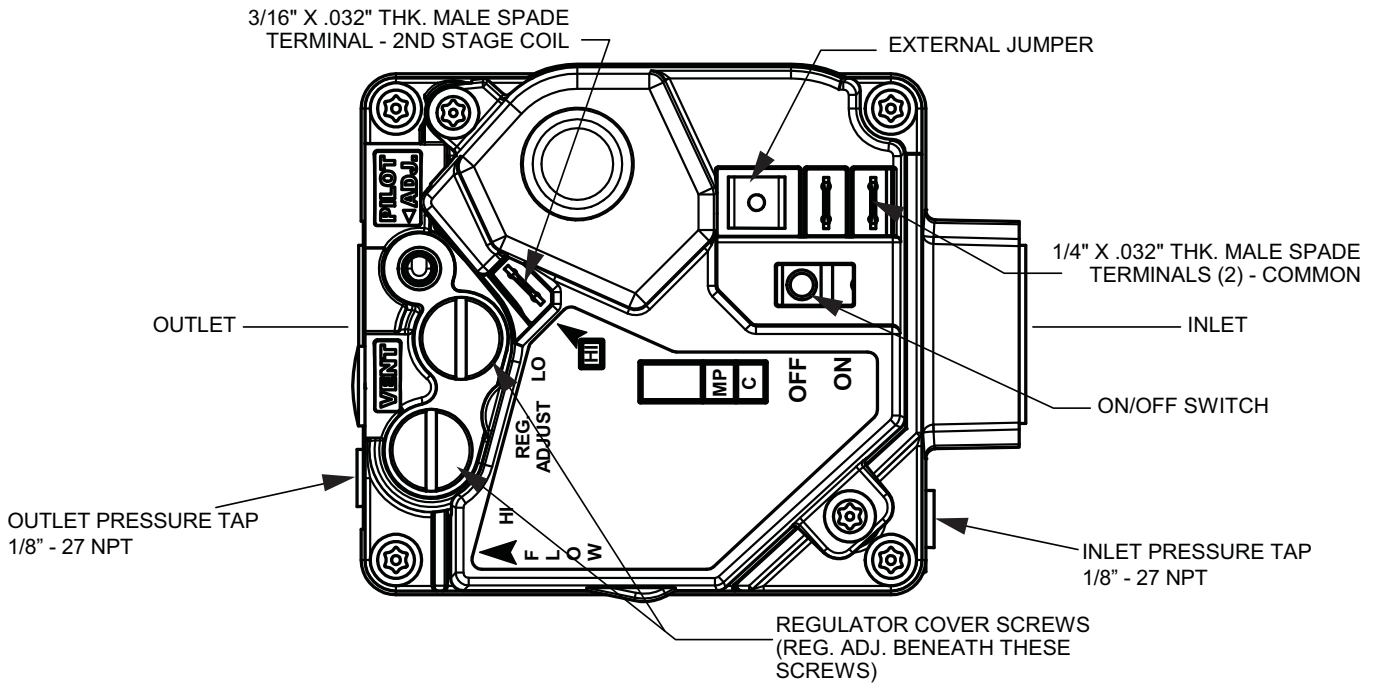
**NOTE:** installation of this furnace at altitudes above 2000 ft (610 m) shall be in accordance with local codes, or in the absence of local codes, the National Fuel Gas Code, ANSI Z223.1/NFPA 54 or National Standard of Canada, Natural Gas and Propane Installation Code, CSA B149.1.



**Figure 28: 3 Thru 5 Ton, 1/2" Single Stage Gas Valve**



**Figure 29: 3 Thru 5 Ton, 1/2" Two Stage Gas Valve**



**Figure 30: 6 Thru 12.5 Ton 3/4" Two Stage Gas Valve**

## Troubleshooting

### ⚠ WARNING

Troubleshooting of components may require opening the electrical control box with the power connected to the unit. **Use extreme care when working with live circuits!** Check the unit nameplate for the correct line voltage and set the voltmeter to the correct range before making any connections with line terminals.

When not necessary, shut off all electric power to the unit prior to any of the following maintenance procedures so as to prevent personal injury.

### ⚠ CAUTION

Label all wires prior to disconnection when servicing controls. Wiring errors can cause improper and dangerous operation, which could cause injury to person and/or damage unit components. Verify proper operation after servicing.

### ⚠ WARNING

The furnace may shut down on a high temperature condition during the procedure. If this occurs, the UCB energize the supply air blower motor until the high temperature limit has reset. Caution should be used at all times as the supply air blower may energize regardless of the room thermostat fan switch position.

**Table 28: Flash Codes for the Gas Heat Ignition Control Board**

Flash Code	Description	Technician Corrective Action	Ignition Control Response to Flash Code	Method for Reset
Heartbeat	<i>Normal Operation</i> - no status or error information currently needs to be displayed	None.	All functions available to respond to heating demand.	None.
Steady Off	a. <i>No Power to the Control</i> - Less than 18 VAC is present at the ignition control's R (P2-2 pin) and C (P2-1 pin) connections	Verify line voltage is present at the primary of the 75VA transformer, verify 24 VAC is present at the secondary of the 75VA transformer. Verify 24 VAC is present from the UCB's C to SD terminals indicating the 3.2A control circuit breaker and phase monitor contacts are closed. Verify 24 VAC is present at the ignition control's R (P2-2 pin) and C (P2-1 pin) connections indicating the unit to ignition control wiring is intact.	The output relay contacts open so inducer and gas valve operation is not permitted.	a. Restoration of 24 VAC power to the ignition control.
	b. The ignition control has catastrophic damage that will not allow the LED display (it is likely that there will be visible physical evidence of the damage)			b. None.
Steady On	The Ignition Control's Microprocessor Has Not Passed its Self-check	Cycle power to the control to eliminate the possibility that transient voltage conditions such as surges, brownouts, etc. have not created a false indication. If the steady on LED indication repeats, the control will need to be replaced and potential causes for failure, such as excessive voltage, RF interference, etc. should be investigated.	The output relay contacts open so inducer and gas valve operation is not permitted.	Cycling 24 VAC power to the ignition control or expiration of the 60 minute "watchdog" timer.
2 Flashes	<i>The Induced Draft Pressure Switch Did Not Close</i> - 24 VAC was not received to the ignition control's pressure switch input (P1-8 pin) within 10 seconds of the ignition control energizing the induced draft motor or 24 VAC was later lost to the control's pressure switch input while the ignition control energized the induced draft motor	Verify that the induced draft motor is operable, the ignition control's L1 to IND contacts are not open, the induced draft blower wheel is intact and there are no blockages in the combustion air / induced draft path. Verify that the induced draft pressure switch sensing tubing is intact. With an incline manometer, digital manometer or Magnehelic® gauge teed into the pressure switch sensing line verify that the negative pressure exceeds the setting listed on the induced draft pressure switch label and the switch's contacts correctly close at the setting listed	Gas valve operation is not permitted/ends when the induced draft pressure switch input is not present. The ignition control's L1 to IND output relay contact will cycle closed for 5 minutes/open for 30 seconds until 24 VAC is received to the pressure switch input or the heating demand ends.	Closure of the pressure switch (24 VAC input to P1-8 pin), cycling first stage heat input or cycling 24 VAC power to the ignition control.
3 Flashes	<i>The Induced Draft Pressure Switch is Stuck Closed</i> - 24 VAC is received to the control's pressure switch input (P1-8 pin) at the same time as 24 VAC to initiate heating operation is received at the control's W1 input (P2-3 pin)	Verify that the induced draft pressure switch contacts are not stuck or welded closed. Verify that the ignition control's L1 to IND contacts are not stuck or welded closed causing the induced draft motor to run continuously. Verify that the wiring from the ignition control's P1-3 pin through the induced draft pressure switch to the ignition control's pressure switch input (P1-8 pin) is not shorted.	The output relay contacts open so inducer and gas valve operation is not permitted.	Opening of the pressure switch (loss of 24 VAC input to P1-8 pin) then cycling first stage heat input or cycling 24 VAC power to the ignition control.

**Table 28: Flash Codes for the Gas Heat Ignition Control Board**

Flash Code	Description	Technician Corrective Action	Ignition Control Response to Flash Code	Method for Reset
4 Flashes	<i>Flame Could Not Be Established</i> - A flame signal of 0.2µa or greater could not be established in three consecutive attempts for ignition at the initiation of the heating cycle	Verify that the unit has proper electrical grounding. Verify the 24 VAC common and ignition control cabinet ground references are intact. Monitor the flame signal. Verify that combustion air openings are without blockages and that the unit has proper clearance to the structure and adjacent units. Verify that the burners are clean and without blockages that could interfere with gas flow. Verify that the ignitor sparks with an ≈1/8" gap to the crossover area of the left burner. Verify that the flame sensor is intact and positioned with an ≈1/8" gap to the right burner. Verify that the gas lines have been purged of air and provide proper gas inlet pressure. Verify that the gas valve is opening and adjusted to provide proper manifold pressure. Verify that the wiring to the gas valve is intact. Verify that there is no wind, rain or snow entering the heat compartment to interfere with ignition or the burners. Verify that there are no conditioned air leaks or heat exchanger breaches to interfere with ignition or the burners.	Immediately after the third ignition trial: the gas valve output relay contact opens so gas valve operation is not permitted, following a 5 second inducer post purge the induced draft output relay contact opens so inducer operation is not permitted.	Cycling first stage heat input, cycling 24 VAC power to the ignition control or expiration of the 60 minute "watchdog" timer.
5 Flashes	<i>Flame Loss</i> - After being established during ignition trials, flame signal dropped below 0.2µa five times during one heating cycle	Verify that the unit has proper electrical grounding. Verify the 24 VAC common and ignition control cabinet ground references are intact. Monitor the flame signal. Verify that combustion air openings are without blockages and that the unit has proper clearance to the structure and adjacent units. Verify that the burners are clean and without blockages that could interfere with gas flow. Verify that the flame sensor is intact and positioned with an ≈1/8" gap to the right burner. Verify that the gas lines have been purged of air and provide proper gas inlet pressure. Verify that the gas valve provides proper manifold pressure. Verify that the wiring to the gas valve is intact. Verify that there is no wind, rain or snow entering the heat compartment to interfere with ignition or the burners. Verify that there are no conditioned air leaks or heat exchanger breaches to interfere with ignition or the burners.	Immediately after the fifth flame loss: the gas valve output relay contact opens so gas valve operation is not permitted, following a 5 second inducer post purge the induced draft output relay contact opens so inducer operation is not permitted.	Cycling first stage heat input, cycling 24 VAC power to the ignition control or expiration of the 60 minute "watchdog" timer.
6 Flashes	<i>Open Limit</i> - 24 VAC has been lost to the control's limit switch input (P1-9 pin) or 24 VAC has been lost to the control's limit switch input (P1-9 pin) for a duration of 6 minutes or less with 24 VAC present at the control's W1 input (P2-3 pin)	Verify proper gas manifold pressure. Correct the inadequate indoor airflow condition. Verify filters, indoor coil and blower wheel are clean. Verify that the blower belt is properly maintained and adjusted; the blower motor fuses are intact, contactor and motor are operable and wheel has the correct rotation. Verify that the ducting is not restrictive. Verify indoor air volume is at least the minimum required for the heat section by using the Airflow Measurement Charts in the Technical Training Manual or other method such as temperature rise, balometer, etc. Verify heating mode blower on/off delays are proper for the heat type and provide adequate heat section cooling at the termination of the heating cycle. Verify wiring for main and auxiliary limit switches is intact.	The gas valve output relay contact opens so gas valve operation is not permitted, the induced draft output relay contact closes to operate the inducer.	Closure of the limit switch(es) (24 VAC input to P1-9 pin)
7 Flashes	<i>Open Rollout</i> - 24 VAC has been lost to the control's rollout switch input (P1-6 pin)	Verify that combustion air openings are without blockages and that the unit has proper clearance to the structure and adjacent units. Verify that the burners are clean and without blockages that could interfere with gas flow. Verify that the ignitor sparks with an ≈1/8" gap to the crossover area of the left burner. Verify that the gas lines provide proper gas inlet pressure. Verify that the gas valve is adjusted to provide proper manifold pressure. Verify that there is no wind, rain or snow entering the heat compartment to interfere with ignition or the burners. Verify that there are no conditioned air leaks or heat exchanger breaches to interfere with ignition or the burners. Verify wiring for the rollout switch is intact.	The gas valve output relay contact opens so gas valve operation is not permitted, following a 5 second inducer post purge the induced draft output relay contact opens so inducer operation is not permitted.	Closure of the rollout switch (24 VAC input to P1-6 pin) then cycling first stage heat input or cycling 24 VAC power to the ignition control.
8 Flashes	<i>The Gas Valve Failed To Shut Off</i> - flame has been sensed for longer than 2 seconds when the first stage gas valve output is off	Verify that the gas valve is not slow to shut off, leaks by or otherwise does not completely shut off gas flow when de-energized. Verify the gas valve wiring to is intact and not shorted in a manner that would improperly allow 24 VAC from another circuit to be applied to the gas valve.	The gas valve output relay contact opens so gas valve operation is not permitted, the induced draft output relay closes to operate the inducer.	Cycling 24 VAC power to the ignition control.

**Table 28: Flash Codes for the Gas Heat Ignition Control Board**

Flash Code	Description	Technician Corrective Action	Ignition Control Response to Flash Code	Method for Reset
9 Flashes	<i>Indoor Airflow Failure Open Limit</i> - 24 VAC has been lost to the control's limit switch input (P1-9 pin) for a duration of more than 6 minutes with 24 VAC present at the control's W1 input (P2-3 pin)	Correct the no/extremely low indoor airflow condition. Verify filters, indoor coil and blower wheel are clean. Verify that the blower belt is intact, properly maintained and adjusted; the blower motor fuses are intact, contactor and motor are operable and wheel has the correct rotation. Verify that the ducting is without blockages. Verify indoor air volume is at least the minimum required for the heat section by using the Airflow Measurement Charts in the Technical Training Manual or other method such as temperature rise, balometer, etc. Verify wiring for main and auxiliary limit switches is intact. Verify main and auxiliary limit switches are not failed in an open position.	The gas valve output relay contact opens so gas valve operation is not permitted, the induced draft output relay contact closes to operate the inducer.	Cycling 24 VAC power to the ignition control.
10 Flashes	<p>a. <i>Gas Valve Miss-wire</i> - 24 VAC has been present for longer than 1 second at the first stage and/or second stage gas valve output (P1-7 pin and/or P1-4 pin) when the gas valve is commanded off by the ignition control</p> <p>b. <i>Ignition Control Gas Valve Relay Contact Failed to Close</i> - 24 VAC has not been sensed for longer than 1 second at the first stage and/or second stage gas valve output (P1-7 pin and/or P1-4 pin) when the gas valve is commanded on by the ignition control</p>	Verify gas valve wiring from the ignition control to the gas valve is intact and not shorted in a manner that would improperly allow 24 VAC from another circuit to be applied to the control's P1-7 and/or P1-4 gas valve output pins. Verify the control's gas valve output relay contacts for first stage (P1-8 to P1-7) and second stage (P1-7 to P1-4) are not shorted or fail to close when commanded on.	Initially, the output relay contacts open. Then, if 24 VAC remains present at the P1-7 pin after 15 seconds, the induced draft output relay contact closes to operate the inducer.	Cycling 24 VAC power to the ignition control.

**Table 29: ZY04 Charging Table**

Air Flow Indoor Db/Wb	Outdoor DB	Suction P	Suction Temp.	Liquid P	Liquid Temp.	Delta T Db	Compr. amps
300 Cfm/Ton 80/62	75	137	59	272	76	-26	8.1
	85	136	57	319	85	-26	9.3
	95	135	56	366	95	-26	10.5
300 Cfm/Ton 80/67	75	136	58	270	77	-25	8.1
	85	139	59	319	86	-24	9.3
	95	142	59	367	95	-23	10.5
300 Cfm/Ton 80/72	75	136	58	269	78	-25	8.1
	85	142	60	319	87	-23	9.3
	95	149	63	369	95	-20	10.5
300 Cfm/Ton 75/62	75	131	56	269	75	-23	8.0
	85	132	55	318	85	-23	9.3
	95	133	55	367	95	-22	10.5
400 Cfm/Ton 80/62	75	141	61	269	77	-24	8.1
	85	142	60	317	87	-23	9.2
	95	143	60	366	96	-23	10.4
400 Cfm/Ton 80/67	75	142	61	269	77	-23	8.1
	85	145	61	319	86	-22	9.3
	95	147	62	370	95	-21	10.5
400 Cfm/Ton 80/72	75	143	62	269	78	-22	8.1
	85	147	63	321	86	-20	9.4
	95	152	64	374	95	-19	10.6
400 Cfm/Ton 75/62	75	135	58	267	77	-21	8.0
	85	137	58	316	86	-20	9.2
	95	139	58	365	96	-20	10.4

**Table 30: ZY05 Charging Table**

Air Flow Indoor Db/Wb	Outdoor DB	Suction P	Suction Temp.	Liquid P	Liquid Temp.	Delta T Db	Compr. amps
300 Cfm/Ton 80/62	75	134	57	285	80	-26	11.1
	85	133	56	333	89	-27	12.8
	95	133	56	381	98	-28	14.4
300 Cfm/Ton 80/67	75	134	56	284	79	-26	11.1
	85	137	57	331	88	-26	12.7
	95	140	58	377	96	-25	14.3
300 Cfm/Ton 80/72	75	133	56	283	78	-27	11.2
	85	140	58	328	86	-24	12.6
	95	147	61	374	94	-22	14.1
300 Cfm/Ton 75/62	75	128	54	284	79	-24	11.0
	85	129	54	332	88	-24	12.7
	95	130	54	380	97	-23	14.4
400 Cfm/Ton 80/62	75	140	59	284	82	-24	11.1
	85	142	59	334	103	-24	12.8
	95	143	59	384	124	-24	14.5
400 Cfm/Ton 80/67	75	142	59	283	82	-23	11.0
	85	144	60	332	90	-23	12.6
	95	147	60	380	98	-22	14.2
400 Cfm/Ton 80/72	75	143	60	283	81	-23	10.9
	85	147	61	330	77	-21	12.4
	95	151	62	377	73	-20	13.9
400 Cfm/Ton 75/62	75	135	56	282	81	-21	11.0
	85	137	57	332	108	-21	12.7
	95	139	57	382	135	-20	14.5



Table 31: ZY06 Charging Table

Air Flow Indoor Db/Wb	Outdoor DB	Suction P	Suction Temp.	Liquid P	Liquid Temp.	Delta T Db	Compr. amps
300 Cfm/Ton 80/62	75	139	65	280	83	-25	13.1
	85	138	63	329	92	-26	14.9
	95	136	62	378	101	-27	16.8
300 Cfm/Ton 80/67	75	140	64	285	83	-25	13.2
	85	141	65	334	92	-25	15.1
	95	143	66	384	100	-24	17.0
300 Cfm/Ton 80/72	75	140	64	290	84	-25	13.3
	85	145	66	340	91	-23	15.3
	95	150	69	390	99	-20	17.2
300 Cfm/Ton 75/62	75	133	61	276	82	-23	12.9
	85	134	61	327	91	-23	14.9
	95	134	61	379	100	-23	16.8
400 Cfm/Ton 80/62	75	144	67	282	82	-23	13.1
	85	145	66	331	92	-23	15.0
	95	146	66	381	102	-23	16.9
400 Cfm/Ton 80/67	75	145	67	286	83	-22	13.3
	85	147	66	331	91	-22	15.0
	95	149	66	377	100	-21	16.7
400 Cfm/Ton 80/72	75	146	66	289	83	-22	13.4
	85	149	67	331	91	-21	14.9
	95	152	67	373	98	-20	16.5
400 Cfm/Ton 75/62	75	138	63	279	81	-20	13.0
	85	140	63	329	91	-20	14.9
	95	142	64	380	100	-19	16.8

Table 32: ZY07 Charging Table

Air Flow Indoor Db/Wb	Outdoor DB	Suction P	Suction Temp.	Liquid P	Liquid Temp.	Delta T Db	Compr. amps
300 Cfm/Ton 80/62	75	135	59	262	76	-26	11.6
	85	134	57	308	85	-26	12.5
	95	134	55	355	94	-27	13.5
300 Cfm/Ton 80/67	75	134	58	259	76	-26	11.6
	85	137	58	308	85	-25	12.6
	95	140	58	357	94	-24	13.6
300 Cfm/Ton 80/72	75	133	56	256	76	-27	11.5
	85	139	59	308	85	-24	12.6
	95	146	61	359	94	-22	13.7
300 Cfm/Ton 75/62	75	129	55	261	76	-23	11.5
	85	130	55	309	85	-23	12.5
	95	131	55	357	94	-23	13.6
400 Cfm/Ton 80/62	75	139	62	262	76	-23	11.6
	85	141	60	309	85	-23	12.6
	95	143	59	355	95	-23	13.6
400 Cfm/Ton 80/67	75	140	61	261	76	-23	11.7
	85	143	61	309	85	-22	12.6
	95	147	60	356	95	-21	13.6
400 Cfm/Ton 80/72	75	140	61	260	76	-23	11.7
	85	146	61	309	85	-21	12.6
	95	151	62	357	95	-20	13.6
400 Cfm/Ton 75/62	75	134	58	262	76	-21	11.6
	85	136	58	309	85	-20	12.6
	95	139	57	356	95	-20	13.6

**Table 33: ZYA7 Charging Table**

Air Flow Indoor Db/Wb	Outdoor DB	Suction P	Suction Temp.	Liquid P	Liquid Temp.	Delta T Db	Compr. amps
300 Cfm/Ton 80/62	75	133	61	262	77	-25	10.8
	85	132	60	305	86	-26	12.0
	95	132	58	349	96	-26	13.3
300 Cfm/Ton 80/67	75	134	60	262	78	-25	10.8
	85	137	60	306	87	-24	12.1
	95	140	60	350	96	-23	13.3
300 Cfm/Ton 80/72	75	135	59	263	79	-25	10.8
	85	141	60	306	88	-22	12.1
	95	147	62	350	97	-20	13.4
300 Cfm/Ton 75/62	75	127	57	261	77	-23	10.7
	85	129	57	305	86	-23	12.0
	95	130	57	350	96	-22	13.3
400 Cfm/Ton 80/62	75	136	64	263	77	-23	10.8
	85	138	63	306	86	-23	12.1
	95	140	62	350	96	-22	13.3
400 Cfm/Ton 80/67	75	138	64	264	77	-22	10.8
	85	141	63	308	87	-21	12.1
	95	145	62	352	96	-21	13.4
400 Cfm/Ton 80/72	75	140	64	265	78	-21	10.8
	85	145	63	309	87	-20	12.2
	95	149	61	354	97	-19	13.5
400 Cfm/Ton 75/62	75	131	60	261	77	-20	10.7
	85	134	60	305	86	-20	12.0
	95	136	60	350	96	-19	13.3

**Table 34: ZY08 Charging Table System 1**

Air Flow Indoor Db/Wb	Outdoor DB	Suction P	Suction Temp.	Liquid P	Liquid Temp.	Delta T Db	Compr. amps
300 Cfm/Ton 80/62	75	133	62	276	77	-26	6.8
	85	132	61	323	87	-26	7.6
	95	131	61	371	97	-27	8.4
300 Cfm/Ton 80/67	75	132	60	270	77	-26	6.7
	85	135	60	319	87	-25	7.5
	95	138	61	367	97	-24	8.3
300 Cfm/Ton 80/72	75	131	57	265	78	-26	6.6
	85	138	59	314	87	-23	7.4
	95	145	61	363	97	-21	8.2
300 Cfm/Ton 75/62	75	127	59	275	77	-24	6.8
	85	128	59	324	87	-23	7.6
	95	128	59	373	97	-23	8.4
400 Cfm/Ton 80/62	75	138	64	276	77	-23	6.8
	85	140	64	323	89	-23	7.5
	95	141	63	370	101	-23	8.3
400 Cfm/Ton 80/67	75	139	63	273	78	-23	6.7
	85	142	63	321	87	-22	7.5
	95	145	63	369	97	-21	8.3
400 Cfm/Ton 80/72	75	140	62	271	78	-23	6.7
	85	145	63	320	86	-21	7.5
	95	149	63	368	94	-20	8.3
400 Cfm/Ton 75/62	75	133	61	275	77	-21	6.8
	85	135	61	323	89	-20	7.6
	95	136	61	371	102	-20	8.4

**Table 35: ZY08 Charging Table System 2**

Air Flow Indoor Db/Wb	Outdoor DB	Suction P	Suction Temp.	Liquid P	Liquid Temp.	Delta T Db	Compr. amps
300 Cfm/Ton 80/62	75	137	61	272	79	-26	6.6
	85	136	60	318	89	-26	7.3
	95	136	58	364	99	-27	8.1
300 Cfm/Ton 80/67	75	136	60	271	78	-26	6.6
	85	139	60	317	88	-25	7.3
	95	143	61	364	99	-24	8.0
300 Cfm/Ton 80/72	75	135	59	270	78	-26	6.6
	85	143	61	317	88	-23	7.3
	95	151	63	365	99	-21	8.0
300 Cfm/Ton 75/62	75	130	58	271	78	-24	6.6
	85	132	57	318	88	-23	7.4
	95	133	57	365	99	-23	8.1
400 Cfm/Ton 80/62	75	141	63	273	78	-23	6.6
	85	143	63	320	90	-23	7.3
	95	144	62	366	101	-23	8.1
400 Cfm/Ton 80/67	75	142	63	273	79	-23	6.6
	85	145	63	320	89	-22	7.3
	95	149	63	367	99	-21	8.1
400 Cfm/Ton 80/72	75	144	63	272	79	-23	6.6
	85	148	64	320	88	-21	7.3
	95	153	64	368	96	-20	8.0
400 Cfm/Ton 75/62	75	136	60	273	78	-21	6.6
	85	138	60	319	90	-20	7.4
	95	140	60	366	103	-20	8.1

**Table 36: ZY09 Charging Table System 1**

Air Flow Indoor Db/Wb	Outdoor DB	Suction P	Suction Temp.	Liquid P	Liquid Temp.	Delta T Db	Compr. amps
300 Cfm/Ton 80/62	75	138	63	278	79	-26	7.7
	85	138	61	325	89	-27	8.5
	95	137	59	371	98	-27	9.3
300 Cfm/Ton 80/67	75	137	62	277	80	-26	7.6
	85	141	62	325	89	-25	8.5
	95	144	62	374	98	-24	9.3
300 Cfm/Ton 80/72	75	137	61	275	80	-27	7.6
	85	144	63	325	90	-24	8.5
	95	151	64	376	99	-21	9.3
300 Cfm/Ton 75/62	75	132	60	277	78	-24	7.6
	85	133	58	325	88	-23	8.5
	95	134	57	372	97	-23	9.4
400 Cfm/Ton 80/62	75	142	66	281	79	-23	7.7
	85	144	64	327	89	-23	8.5
	95	146	63	374	99	-23	9.4
400 Cfm/Ton 80/67	75	143	65	279	80	-23	7.7
	85	147	64	327	90	-22	8.5
	95	150	64	375	99	-21	9.4
400 Cfm/Ton 80/72	75	144	64	278	81	-23	7.7
	85	149	64	327	90	-21	8.5
	95	155	65	376	99	-20	9.3
400 Cfm/Ton 75/62	75	137	62	280	79	-21	7.7
	85	139	61	327	88	-20	8.5
	95	141	61	375	98	-20	9.4

**Table 37: ZY09 Charging Table System 2**

Air Flow Indoor Db/Wb	Outdoor DB	Suction P	Suction Temp.	Liquid P	Liquid Temp.	Delta T Db	Compr. amps
300 Cfm/Ton 80/62	75	137	64	278	78	-26	7.2
	85	137	62	323	88	-27	8.1
	95	137	59	369	98	-27	8.9
300 Cfm/Ton 80/67	75	137	62	275	78	-26	7.2
	85	140	62	324	88	-25	8.1
	95	143	62	374	99	-24	9.0
300 Cfm/Ton 80/72	75	137	60	272	78	-27	7.1
	85	143	62	325	89	-24	8.1
	95	149	64	378	99	-21	9.1
300 Cfm/Ton 75/62	75	132	60	276	78	-24	7.2
	85	133	59	322	88	-23	8.1
	95	135	58	369	98	-23	8.9
400 Cfm/Ton 80/62	75	141	67	280	78	-23	7.3
	85	143	65	326	89	-23	8.1
	95	146	63	372	99	-23	9.0
400 Cfm/Ton 80/67	75	142	66	279	78	-23	7.2
	85	146	65	327	89	-22	8.1
	95	149	64	376	99	-21	9.0
400 Cfm/Ton 80/72	75	144	65	277	78	-23	7.2
	85	148	65	328	89	-21	8.1
	95	152	65	379	99	-20	9.1
400 Cfm/Ton 75/62	75	136	63	278	78	-21	7.3
	85	139	62	325	88	-20	8.1
	95	142	61	373	98	-20	9.0

**Table 38: ZY12 Charging Table System 1**

Air Flow Indoor Db/Wb	Outdoor DB	Suction P	Suction Temp.	Liquid P	Liquid Temp.	Delta T Db	Compr. amps
300 Cfm/Ton 80/62	75	135	59	284	81	-26	8.9
	85	135	58	332	90	-26	10.0
	95	135	58	380	98	-27	11.0
300 Cfm/Ton 80/67	75	134	59	285	81	-26	9.1
	85	138	59	334	91	-25	10.1
	95	142	60	383	100	-24	11.0
300 Cfm/Ton 80/72	75	132	58	285	81	-26	9.3
	85	141	60	336	91	-23	10.1
	95	149	62	387	101	-20	11.0
300 Cfm/Ton 75/62	75	129	56	282	80	-23	8.9
	85	131	56	330	89	-23	10.0
	95	133	56	379	98	-23	11.0
400 Cfm/Ton 80/62	75	139	61	285	83	-23	9.0
	85	142	61	333	91	-23	10.0
	95	144	61	382	100	-23	11.0
400 Cfm/Ton 80/67	75	140	61	287	82	-22	9.1
	85	144	62	336	91	-22	10.1
	95	148	62	385	100	-21	11.1
400 Cfm/Ton 80/72	75	140	61	289	82	-22	9.2
	85	146	62	338	91	-20	10.2
	95	151	63	388	100	-19	11.1
400 Cfm/Ton 75/62	75	134	58	284	81	-20	9.0
	85	137	58	332	90	-20	10.0
	95	140	59	381	99	-19	11.0

**Table 39: ZY12 Charging Table System 2**

<b>Air Flow Indoor Db/Wb</b>	<b>Outdoor DB</b>	<b>Suction P</b>	<b>Suction Temp.</b>	<b>Liquid P</b>	<b>Liquid Temp.</b>	<b>Delta T Db</b>	<b>Compr. amps</b>
300 Cfm/Ton 80/62	75	134	60	279	79	-26	8.4
	85	135	59	327	88	-26	9.4
	95	135	59	376	98	-27	10.3
300 Cfm/Ton 80/67	75	135	60	279	79	-26	8.6
	85	139	60	330	89	-25	9.5
	95	142	60	381	99	-24	10.4
300 Cfm/Ton 80/72	75	136	60	280	79	-26	8.8
	85	143	61	332	89	-23	9.6
	95	150	62	385	99	-20	10.5
300 Cfm/Ton 75/62	75	128	57	278	78	-23	8.4
	85	130	57	328	88	-23	9.4
	95	132	57	377	98	-23	10.4
400 Cfm/Ton 80/62	75	139	62	278	80	-23	8.4
	85	141	62	328	89	-23	9.3
	95	143	61	378	99	-23	10.2
400 Cfm/Ton 80/67	75	141	62	280	79	-22	8.6
	85	144	62	331	89	-22	9.5
	95	147	63	381	98	-21	10.4
400 Cfm/Ton 80/72	75	142	62	282	78	-22	8.7
	85	147	63	333	88	-20	9.6
	95	152	64	385	98	-19	10.5
400 Cfm/Ton 75/62	75	134	59	278	79	-20	8.4
	85	137	59	328	88	-20	9.3
	95	139	59	378	98	-19	10.3

## Smart Equipment™ Control Board Navigation Components

The following components are needed to access the control points in the Smart Equipment™ control. Installation and operation guides are available from your equipment dealer or distributor.

1. Local LCD on Unit Control Board.
2. Mobile Access Portal (MAP) Gateway (Portable).
  - Source 1 P/N S1-JC-MAP1810-OP

3. *MAP Gateway Quick Start Guide* P/N 24-10737-16

4. *MAP Gateway Instruction* P/N 24-10737-8

For more information on the Smart Equipment™ unit control board navigation, refer to the *Smart Equipment™ Quick Start Guide*.

**NOTE:** For more in-depth sequence of operation of the Smart Equipment™ control, refer to the *Smart Equipment™ Controls Sequence of Operation Overview* LIT-12011950.

**Start-Up Sheet****START-UP & SERVICE DATA INSTRUCTION****COMMERCIAL PACKAGE UNITS****3.0 To 40.0 TONS****START-UP CHECKLIST**

Date: \_\_\_\_\_

Job Name: \_\_\_\_\_

Customer Name: \_\_\_\_\_

Address: \_\_\_\_\_

City: \_\_\_\_\_ State: \_\_\_\_\_ Zip: \_\_\_\_\_

Model Number: \_\_\_\_\_ Serial Number: \_\_\_\_\_

Qualified Start-up Technician: \_\_\_\_\_ Signature: \_\_\_\_\_

HVAC Contractor: \_\_\_\_\_ Phone: \_\_\_\_\_

Address: \_\_\_\_\_

Contractor's E-mail Address: \_\_\_\_\_

Electrical Contractor: \_\_\_\_\_ Phone: \_\_\_\_\_

Distributor Name: \_\_\_\_\_ Phone: \_\_\_\_\_

**WARRANTY STATEMENT**

Johnson Controls/Ducted Systems is confident that this equipment will operate to the owner's satisfaction if the proper procedures are followed and checks are made at initial start-up. This confidence is supported by the 30 day dealer protection coverage portion of our standard warranty policy which states that Johnson Controls/Ducted Systems will cover parts and labor on new equipment start-up failures that are caused by a defect in factory workmanship or material, for a period of 30 days from installation. Refer to the current standard warranty policy and warranty manual for details.

In the event that communication with Johnson Controls/Ducted Systems is required regarding technical and/or warranty concerns, all parties to the discussion should have a copy of the equipment start-up sheet for reference. A copy of the original start-up sheet should be filed with the Technical Services Department.

The packaged unit is available in constant or variable air volume versions with a large variety of custom options and accessories available. Therefore, some variation in the startup procedure will exist depending upon the products capacity, control system, options and accessories installed.

This start-up sheet covers all startup check points common to all package equipment. In addition it covers essential startup check points for a number of common installation options. Depending upon the particular unit being started not all sections of this startup sheet will apply. Complete those sections applicable and use the notes section to record any additional information pertinent to your particular installation.

Warranty claims are to be made through the distributor from whom the equipment was purchased.

**EQUIPMENT STARTUP**


**Use the local LCD or Mobile Access Portal (MAP) Gateway to complete the start-up.**


**A copy of the completed start-up sheet should be kept on file by the distributor providing the equipment and a copy sent to:**

Johnson Controls/Ducted Systems  
Technical Services Department  
5005 York Drive  
Norman, OK 73069

**SAFETY WARNINGS**

The inspections and recording of data outlined in this procedure are required for start-up of Johnson Controls/Ducted Systems' packaged products. Industry recognized safety standards and practices must be observed at all times. General industry knowledge and experience are required to assure technician safety. It is the responsibility of the technician to assess all potential dangers and take all steps warranted to perform the work in a safe manner. By addressing those potential dangers, prior to beginning any work, the technician can perform the work in a safe manner with minimal risk of injury.

 <b>WARNING</b>
Lethal voltages are present during some start-up checks. Extreme caution must be used at all times.

 <b>WARNING</b>
Moving parts may be exposed during some startup checks. Extreme caution must be used at all times.

**NOTE:** Read and review this entire document before beginning any of the startup procedures.

**DESIGN APPLICATION INFORMATION**

This information will be available from the specifying engineer who selected the equipment. If the system is a VAV system the CFM will be the airflow when the remote VAV boxes are in the

full open position and the frequency drive is operating at 60 HZ. **Do not proceed with the equipment start-up without the design CFM information.**

Design Supply Air CFM: \_\_\_\_\_ Design Return Air CFM: \_\_\_\_\_

Design Outdoor Air CFM At Minimum Position: \_\_\_\_\_

Total External Static Pressure: \_\_\_\_\_

Supply Static Pressure: \_\_\_\_\_

Return Static Pressure: \_\_\_\_\_

Design Building Static Pressure: \_\_\_\_\_

Outside Air Dilution: Economizer Position Percentage: \_\_\_\_\_ CFM: \_\_\_\_\_

Supply Gas Pressure After Regulator W/o Heat Active \_\_\_\_\_ Inches \_\_\_\_\_

ADDITIONAL APPLICATION NOTES FROM SPECIFYING ENGINEER:



1034349-UCL-F-0318

## REFERENCE

General Inspection	Completed	See Notes
Unit inspected for shipping, storage, or rigging damage	<input type="checkbox"/>	<input type="checkbox"/>
Unit installed with proper clearances	<input type="checkbox"/>	<input type="checkbox"/>
Unit installed within slope limitations	<input type="checkbox"/>	<input type="checkbox"/>
Refrigeration system checked for gross leaks (presence of oil)	<input type="checkbox"/>	<input type="checkbox"/>
Terminal screws and wiring connections checked for tightness	<input type="checkbox"/>	<input type="checkbox"/>
Filters installed correctly and clean	<input type="checkbox"/>	<input type="checkbox"/>
Economizer hoods installed in operating position	<input type="checkbox"/>	<input type="checkbox"/>
Condensate drain trapped properly, refer to Installation Manual	<input type="checkbox"/>	<input type="checkbox"/>
Economizer damper linkage tight	<input type="checkbox"/>	<input type="checkbox"/>
Gas Heat vent hood installed	<input type="checkbox"/>	<input type="checkbox"/>
All field wiring (power and control) complete	<input type="checkbox"/>	<input type="checkbox"/>

Air Moving Inspection	Completed	See Notes
Alignment of drive components	<input type="checkbox"/>	<input type="checkbox"/>
Belt tension adjusted properly	<input type="checkbox"/>	<input type="checkbox"/>
Blower pulleys tight on shaft, bearing set screws tight, wheel tight to shaft	<input type="checkbox"/>	<input type="checkbox"/>
Pressure switch or transducer tubing installed properly	<input type="checkbox"/>	<input type="checkbox"/>

Exhaust Inspection    Powered <input type="checkbox"/> Barometric Relief <input type="checkbox"/>	Completed	See Notes
Check hub for tightness	<input type="checkbox"/>	<input type="checkbox"/>
Check fan blade for clearance	<input type="checkbox"/>	<input type="checkbox"/>
Check for proper rotation	<input type="checkbox"/>	<input type="checkbox"/>
Check for proper mounting (screen faces towards unit)	<input type="checkbox"/>	<input type="checkbox"/>
Prove operation by increasing minimum setting on economizer	<input type="checkbox"/>	<input type="checkbox"/>

Economizer Inspection    Standard <input type="checkbox"/> BAS <input type="checkbox"/>	Completed	See Notes
CO <sub>2</sub> sensor installed    Yes <input type="checkbox"/> No <input type="checkbox"/>	<input type="checkbox"/>	<input type="checkbox"/>
Check economizer setting (Reference Smart Equipment™ Control Board LCD menu location)	<input type="checkbox"/>	<input type="checkbox"/>
Prove economizer open/close through Smart Equipment™ Board Setting	<input type="checkbox"/>	<input type="checkbox"/>

Reheat Mode    Normal <input type="checkbox"/> or Alternate <input type="checkbox"/> Not Applicable <input type="checkbox"/>
Humidity Sensor (2SH0401) _____



1034349-UCL-F-0318

**OPERATING MEASUREMENTS - COOLING**

Stage	Discharge Pressure	Discharge Temp.	Liquid Line Temp. <sup>1</sup>	Subcooling <sup>2</sup>	Suction Pressure	Suction Temp.	Superheat
First	#	°	°	°	#	°	°
Second (if equipped)	#	°	°	°	#	°	°
Third (if equipped)	#	°	°	°	#	°	°
Fourth (if equipped)	#	°	°	°	#	°	°
Reheat 1st Stage	#	°	°	°	#	°	°

1. Liquid temperature should be taken before filter/drier.

2. Subtract 10 psi from discharge pressure for estimated liquid line pressure

Outside air temperature \_\_\_\_\_ °F db \_\_\_\_\_ °F wb \_\_\_\_\_ %RH  
 Return Air Temperature \_\_\_\_\_ °F db \_\_\_\_\_ °F wb \_\_\_\_\_ %RH  
 Mixed Air Temperature \_\_\_\_\_ °F db \_\_\_\_\_ °F wb \_\_\_\_\_ %RH  
 Supply Air Temperature \_\_\_\_\_ °F db \_\_\_\_\_ °F wb \_\_\_\_\_ %RH

**REFRIGERANT SAFETIES**

Action	Completed	See Notes
Prove Compressor Rotation (3 phase only) by gauge pressure	<input type="checkbox"/>	<input type="checkbox"/>
Prove High Pressure Safety, All Systems	<input type="checkbox"/>	<input type="checkbox"/>
Prove Low Pressure Safety, All Systems	<input type="checkbox"/>	<input type="checkbox"/>

**OPERATING MEASUREMENTS - GAS HEATING**Fuel Type:  Natural Gas  LP Gas

Action	Completed	See Notes
Check for gas leaks	<input type="checkbox"/>	<input type="checkbox"/>
Prove Ventor Motor Operation	<input type="checkbox"/>	<input type="checkbox"/>
Prove Primary Safety Operation	<input type="checkbox"/>	<input type="checkbox"/>
Prove Auxiliary Safety Operation	<input type="checkbox"/>	<input type="checkbox"/>
Prove Rollout Switch Operation	<input type="checkbox"/>	<input type="checkbox"/>
Prove Smoke Detector Operation	<input type="checkbox"/>	<input type="checkbox"/>
Manifold Pressure	Stage 1	IWC <input type="checkbox"/>
	Stage 2 (If Equipped)	IWC <input type="checkbox"/>
	Stage 3 (If Equipped)	IWC <input type="checkbox"/>
Supply gas pressure at full fire	IWC	<input type="checkbox"/>
Check temperature rise <sup>1</sup>	<input type="checkbox"/> measured at full fire	°F <input type="checkbox"/>

1. Input X Eff. (BTU output)

1.08 X Temp. Rise

## OPERATIONAL MEASUREMENTS - STAGING CONTROLS

<b>Verify Proper Operation of Heating/Cooling Staging Controls</b>	
Create a cooling demand at the Thermostat, BAS System or Smart Equipment™ Verify that cooling/economizer stages are energized.	<input type="checkbox"/>
Create a heating demand at the Thermostat, BAS System or Smart Equipment™ Verify that heating stages are energized.	<input type="checkbox"/>
<b>Verify Proper Operation of the Variable Frequency Drive (If Required)</b>	
Verify that motor speed modulates with duct pressure change.	<input type="checkbox"/>

### FINAL - INSPECTION

Verify that all operational control set points have been set to desired value Scroll through all setpoints and change as may be necessary to suit the occupant requirements.	<input type="checkbox"/>
Verify that all option parameters are correct Scroll through all option parameters and ensure that all installed options are enabled in the software and all others are disabled in the software. (Factory software settings should match the installed options)	<input type="checkbox"/>
Verify that all access panels have been closed and secured	<input type="checkbox"/>
Save a backup file from the unit control board onto a USB flash drive.	<input type="checkbox"/>

### OBSERVED PRODUCT DEFICIENCIES & CONCERNS:

---

---

---

---

---

---

---

---

---

---

---

---

---

---

---

---

---

---

---

---

---

---

---

---